

FILED
COMMUNICATIONS
2000 FEB 14 PM 3:16



Bell Atlantic
1095 Avenue of the Americas
Room 3745
New York, New York 10036

212-395-6515 (phone)
212-768-7568 (fax)

Sandra Dilorio Thorn
General Counsel, NY

February 14, 2000

BY HAND

294

Ms. Debra Renner
Acting Secretary
New York Public Service Commission
Three Empire State Plaza
Albany, New York 12223

**Re: Interconnection Agreement between
Bell Atlantic – New York and Jato Operating Two Corp.**

Dear Secretary Renner:

In accordance with § 252(e) of the Telecommunications Act of 1996 (the “Act”), New York Telephone Company, d/b/a Bell Atlantic - New York (“BA-NY”), is herewith filing an Interconnection Agreement effective December 21, 1999 between BA-NY and Jato Operating Two Corp. (“Jato”), governing interconnection arrangements in the State of New York. The Agreement is submitted for Commission approval under §§ 252(e)(1) and (e)(2).

The Act specifies in § 252(e)(4) that, if a state agency does not act to approve or reject an agreement reached by negotiation within 90 days following the filing, it shall be deemed approved.

Pursuant to the Commission’s Notice of Procedures issued June 14, 1996, copies of this Agreement and this letter are being served on all active parties in Cases 95-C-0657 and 93-C-

Ms. Debra Renner
February 14, 2000
Page 2

0103, as well as all telecommunications carriers from which BA-NY has received a request for interconnection, services or network elements pursuant to 47 U.S.C. § 252.

Jato is represented by:

Andrew R. Newell, Esq.
Jato Communications Corp.
1099 18th Street, Suite 2200
Denver, CO 80202

If you have any questions regarding this matter, please feel free to call me.

Respectfully submitted,

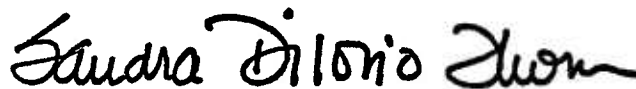

Sandra DiIorio Thorn

Enclosure

cc: Andrew R. Newell, Esq. (By U.S. Mail)
Service List in Cases 95-C-0657 and 93-C-0103 (By U.S. Mail)
All Telecommunications Carriers Requesting Interconnection (By U.S. Mail)

**INTERCONNECTION AGREEMENT UNDER SECTIONS 251 AND 252 OF THE
TELECOMMUNICATIONS ACT OF 1996**

Dated as of December 21, 1999

by and between

**NEW YORK TELEPHONE COMPANY,
d/b/a
BELL ATLANTIC - NEW YORK**

and

JATO OPERATING TWO CORP.

INTERCONNECTION AGREEMENT UNDER SECTIONS 251 AND 252 OF THE TELECOMMUNICATIONS ACT OF 1996

This Interconnection Agreement (this "Agreement"), under Sections 251 and 252 of the Telecommunications Act of 1996 (the "Act"), is effective as of the 21st day of December, 1999 (the "Effective Date"), by and between New York Telephone Company, d/b/a Bell Atlantic - New York ("BA"), a New York corporation with offices at 1095 Avenue of the Americas, New York, New York 10036, and Jato Operating Two Corp., a Delaware corporation with offices at 1099 18th Street, Suite 2200, Denver, Colorado 80202 (each, a "Party" and, collectively, the "Parties").

WHEREAS JATO has requested, pursuant to Section 252(i) of the Act, that BA make available to JATO Interconnection, services and unbundled Network Elements upon the same terms and conditions as provided in the Interconnection Agreement (and any amendments thereto that have been approved by applicable law) between Covad Communications Company and BA, dated as of December 16, 1997, for New York, approved by the Commission under Section 252 of the Act, copies of which agreement and amendments are attached hereto as Appendix 1 (the "Separate Agreement"); and

WHEREAS, BA has undertaken to make such terms and conditions available to JATO hereby only because of, and to the extent required by, Section 252(i) of the Act;

NOW, THEREFORE, in consideration of the mutual provisions contained herein, and for other good and valuable consideration, the receipt and sufficiency of which are hereby acknowledged, JATO and BA hereby agree as follows:

1.0 Incorporation of Separate Agreement by Reference

1.1 Except as expressly stated herein, the terms and conditions of the Separate Agreement, as it is in effect on the date hereof after giving effect to operation of law, are incorporated by reference in their entirety herein and form an integral part of this Agreement.

1.2 References in the Separate Agreement to Covad Communications Company or to Covad shall for purposes of this Agreement be deemed to refer to JATO.

1.3 References in the Separate Agreement to the "Effective Date", the date of effectiveness thereof and like provisions shall for purposes of this Agreement be deemed to refer to the date first written above. Unless terminated earlier in accordance with the terms of the Separate Agreement, this Agreement shall continue in effect until the later of the date (a) of expiration of the initial term of the Separate Agreement (which for avoidance of any doubt, is March 15, 2001) or (b) the Separate Agreement is otherwise terminated or expires.

1.4 All references in the Separate Agreement to "800/888" shall be deleted in their entirety and replaced with the following: "800/888/877".

1.5 All certificates or other proof of insurance to be sent to BA under Section 2.4.27 of the Separate Agreement shall be sent to the following address:

Director - Interconnection Services
Bell Atlantic – Telecom Industry Services
Room 1423
1095 Avenue of the Americas
New York, New York 10036

1.6 Notices to JATO under Section 17 of the Separate Agreement shall be sent to the following address:

Patrick M. Green, Vice President – Carrier Relations
Jato Communications Corp.
1099 18th Street, Suite 2200
Denver, CO 80202
Facsimile: (303) 297-8905

1.7 Notices to BA under Section 17 of the Separate Agreement shall be sent to the following address:

Director - Interconnection Services
Bell Atlantic – Telecom Industry Services
Room 1423
1095 Avenue of the Americas
New York, New York 10036
Facsimile: 212/704-4381

with a copy to:

Bell Atlantic Network Services, Inc.
Attn: Jack H. White, Jr.
Associate General Counsel
1320 N. Court House Road, 8th Floor
Arlington, Virginia 22201
Telephone: (703) 974-1368
Facsimile: (703) 974-0744

with a copy to:

Bell Atlantic – New York
Attn: General Counsel
37th Floor

1095 Avenue of the Americas
New York, New York 10036

2.0 Clarifications

2.1 The Parties agree that if any judicial or regulatory authority of competent jurisdiction determines (or has determined) that BA is not required to furnish any service or item or provide any benefit to Telecommunications Carriers otherwise required to be furnished or provided to JATO hereunder, then BA may, at its sole option, avail itself of any such determination by providing written notice thereof to JATO.

2.2 Notwithstanding anything to the contrary contained in this Agreement, the Parties agree that BA shall only be required to provide combinations and any services related to its provision of combinations to the extent (a) required by applicable law or (b) mutually agreed to by the Parties in writing after the date hereof.

2.3 For the avoidance of doubt, the Parties acknowledge and agree that the term "Dedicated Transport", as described in Section 2.9.5.2 of the Separate Agreement, includes subscriber premises only if such premises contain Central Office switching equipment used for interoffice transmission to and from the other end of the Dedicated Transport path.

2.4 The entry into, filing and performance by BA of this Agreement does not in any way constitute a waiver by BA of any of the rights and remedies it may have to seek review of any of the provisions of the Separate Agreement, or to petition the Commission, other administrative body or court for reconsideration or reversal of any determination made by any of them, or to seek review in any way of any portion of this Agreement in connection with JATO's election under Section 252(i) of the Act.

2.5 Notwithstanding any other provisions of this Agreement, BA shall have no obligation to perform under this Agreement until such time as JATO has obtained a Certificate of Public Convenience and Necessity ("CPCN") or such other Commission authorization as may be required by law as a condition for conducting business in the state of New York as a local exchange carrier.

IN WITNESS WHEREOF, the Parties hereto have caused this Agreement to be executed as of the date first set above.

JATO OPERATING TWO CORP.

By: _____

Printed: _____

Title: _____

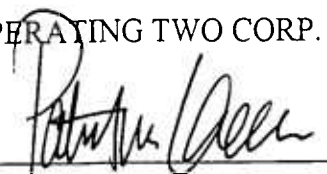

PATRICK M. GREEN
V.P.

BELL ATLANTIC - NEW YORK

By: _____

Printed: _____

Title: Vice-President - Interconnection Services
Policy & Planning

Jeffrey A. Masoner

APPENDIX 1

AGREEMENT

between

New York Telephone Company
d/b/a Bell Atlantic

and

Covad Communications Company

TABLE OF CONTENTS
INTERCONNECTION AGREEMENT

	Page
<u>RECITALS</u>	1
<u>DEFINITIONS</u>	1
<u>GENERAL TERMS AND CONDITION</u>	2
1. <u>Scope of the Agreement</u>	2
2. <u>Term of Agreement; Termination</u>	2
3. <u>Transitional Support</u>	3
4. <u>Good Faith Performance</u>	3
5. <u>Option to Obtain Services, Unbundled Network Elements or Combinations Under Other Agreements</u>	4
6. <u>Responsibility of Each Party</u>	4
7. <u>Government Compliance</u>	5
8. <u>Regulatory Matters</u>	6
9. <u>Liability and Indemnity</u>	6
9.1 <u>Indemnification</u>	6
9.2 <u>Limitation of Liability</u>	7
10. <u>Payment Terms, Disputed Amounts and Audits</u>	8
10.1.....	8

10.2 <u>Payment Terms - Other than Local Services</u>	9
10.3 <u>Disputed Amounts - Other than Local Services</u>	10
10.5 <u>Audits and Inspections</u>	13
10.5 <u>Alternate Billing to Third Numbers</u>	14
10.6 <u>Reciprocal Compensation</u>	15
11. <u>Service Standards</u>	16
12. <u>OSS/Electronic Interfaces</u>	19
13. <u>Operations Plan and Implementation Team</u>	20
14. <u>Force Majeure</u>	20
15. <u>Certain State and Local Taxes</u>	20
16.1 <u>Inter-Company Review Board</u>	22
16.2 <u>Non-Service Affecting Disputes</u>	23
16.3 <u>Service Affecting Disputes</u>	26
16.4 <u>Confidentiality</u>	27
17. <u>Notices</u>	28
17A. <u>Non-Waiver</u>	29
18. <u>Confidentiality</u>	31
19. <u>Number Portability</u>	32

19.1 <u>Interim Number Portability</u>	32
19.2 <u>Number Reassignment</u>	35
20. <u>Directory Listings and Directory Distributions</u>	35
21. <u>Subscriber List Information</u>	37
22. <u>Parity</u>	38
23. <u>Miscellaneous</u>	38
23.1 <u>Delegation or Assignment</u>	38
23.2 <u>Nonexclusive Remedies</u> -	38
23.3 <u>No Third Party Beneficiaries</u>	39
23.4 <u>Referenced Documents</u>	39
23.5 <u>Governing Law</u>	39
23.6 <u>Publicity and Advertising</u>	39
23.7 <u>Amendments or Waivers</u>	40
23.8 <u>Severability</u>	40
23.9 <u>Entire Agreement</u>	40
23.10 <u>Survival of Obligations</u>	41
23.11 <u>Executed in Counterparts</u>	41
22.12 <u>Headings of No Force or Effect</u>	41

23.13 <u>Joint Work Product</u>	41
23.14 <u>Nonexclusive Dealings</u>	41
23.15 <u>No License</u>	41
23.16 <u>Dialing Parity</u>	42
23.17 <u>Integrity of BELL ATLANTIC Network</u>	42
Part I.....	43
Part II.....	44
1. <u>Introduction</u>	45
2. <u>Unbundled Network Elements</u>	46
3. <u>Combinations</u>	71
4. <u>MLT Testing</u>	73
EXHIBIT A to Part II.....	74
PART III: SERVICE DESCRIPTION – ANCILLARY FUNCTIONS.....	76
1. <u>Intentionally Omitted</u>	76
2. <u>Collocation</u>	76
2.1 <u>Definition</u>	76
2.2 <u>Technical Requirements</u>	76
2.3 <u>Technical References</u>	94

2.4 <u>Other Requirements</u>	95
2.5 <u>Virtual Collocation</u>	109
3. <u>Rights of Way</u>	115
4. <u>Dark Fiber</u>	115
Appendix A.....	119
Appendix B.....	125
Appendix C.....	139
Appendix D.....	140
Appendix E.....	139
PART IV: PRICING SCHEDULE	144
A. UNBUNDLED NETWORK ELEMENTS	144
B. OTHER RATES	144
Reciprocal Compensation.....	144
Information Services Fees.....	144
BLV/BLVI Traffic.....	145
Transit Service.....	145
Interim Number Portability.....	146
IntraLATA 800.....	146

<u>Additional Charges</u>	153
<u>Electronic Copies</u>	153
RATE APPLICATION RULES	153
<u>General</u>	153
<u>Reciprocal Compensation</u>	155
<u>Unbundled Network Elements</u>	155
<u>Transient Tandem Process and Pricing</u>	157
<u>Links</u>	157
<u>Non-Recurring</u>	157
EXHIBIT A TO PART IV.....	160
PART V: INTERCONNECTION.....	192
<u>ATTACHMENT 1: DEFINITIONS</u>	193
<u>ATTACHMENT 2 - OPERATIONS PLAN & IMPLEMENTATION TEAM</u>	200
<u>ATTACHMENT 3</u>	204
<u>ATTACHMENT 4</u>	205
<u>ATTACHMENT 5</u>	205
<u>ATTACHMENT 6 - BILLING AND RECORDING</u>	206
APPENDIX 1 - CARRIER BILLING MANAGEMENT.....	231

INTERCONNECTION AGREEMENT

This Agreement, which shall become effective upon the date approved in accordance with Section 2(a), is entered into by and between COVAD Communications Co., d/b/a COVAD, a California corporation, having an office at 3650 Bassett St., Santa Clara, CA 95054 ("COVAD"), and New York Telephone Company, d/b/a BELL ATLANTIC, a New York corporation, having an office at 1095 Avenue of the Americas, New York, New York 10036 ("BELL ATLANTIC" or "NYNEX").

RECITALS

WHEREAS, the Telecommunications Act of 1996 (as amended or modified from time to time, the "Act") was signed into law on February 8, 1996; and

WHEREAS, the Act places certain duties and obligations upon, and grants certain rights to, Telecommunications Carriers; and

WHEREAS, the Federal Communications Commission (the "FCC") has issued rules to implement the Act (including In the Matter of the Local Competition Provisions in the Telecommunications Act of 1996, FCC 96-325 (hereinafter, as amended, modified, stayed or reconsidered from time to time, the "Order"); and

WHEREAS, the Parties are entering into this Agreement to set forth the respective obligations of the Parties and the terms and conditions under which COVAD will interconnect with the BELL ATLANTIC network in the BELL ATLANTIC service territory within the State of New York (the "NY Region") and BELL ATLANTIC will provide services to COVAD as required by the Act and Order and additional services as set forth herein; and

WHEREAS, the Parties have arrived at this Agreement through negotiations undertaken pursuant to the Act.

NOW, THEREFORE, in consideration of the premises and the mutual covenants of this Agreement and other good and valuable consideration, COVAD and BELL ATLANTIC hereby agree as follows:

DEFINITIONS

For purposes of this Agreement, certain terms have been defined in Attachment 1 and elsewhere in this Agreement to encompass meanings that may differ from, or be in addition to, the normal connotation of the defined word. Unless the context clearly indicates otherwise, any term defined or used in the singular shall include the plural. The words "shall" and "will" are used interchangeably throughout the Agreement and the use of either connotes a mandatory requirement. The use of one or the other shall not mean a different degree of right or obligation for either Party. A defined word intended to convey its special meaning is capitalized when used. Other terms that are capitalized,

and not defined in this Agreement, shall have the meaning in the Act.

GENERAL TERMS AND CONDITIONS

1. **Scope of the Agreement** This Agreement together with all applicable tariffs referenced herein (as in effect from time to time) set forth the terms, conditions and prices to which BELL ATLANTIC and COVAD have agreed in respect of the following: (a) certain unbundled network elements, (hereinafter collectively referred to as unbundled "Network Elements"), (b) Collocation, (c) Number Portability, (d) Directory Assistance and Operator Services and Directory Listings, (e) Reciprocal Compensation, (f) E911 and 911 services, (g) Meet-Point Billing, (h) Dialing Parity, (i) Transient Tandem Service, (j) Interconnection of COVAD's network to BELL ATLANTIC's network and (k) Access to Telephone Numbers. This Agreement includes the General Terms and Conditions, Parts I through V, and their Attachments and all accompanying Appendices and Exhibits. Unless otherwise provided in this Agreement, the rights and obligations of the Parties hereunder shall apply throughout the NY Region.

2. **Term of Agreement; Termination**
 - (a) The initial term of this Agreement shall commence on the date on which this Agreement has been approved in its entirety by the Commission or the FCC as contemplated in Section 252 of the Act (the "Effective Date") and shall expire on March 15, 2001 ("Term"), except as otherwise provided in Section 2(d) below.

 - (b) COVAD (i) shall, at BELL ATLANTIC's request, or (ii) may, at its option, nine months prior to the expiration of the Term, make a request to BELL ATLANTIC to renegotiate the terms of this Agreement pursuant to Section 251(c)(1) of the Act. The date of BELL ATLANTIC's receipt of such request shall be hereinafter referred to as the "Renegotiation Request Date". The Parties agree that within sixty (60) days of such Renegotiation Request Date each Party will provide to the other a written description of its proposed changes to the Agreement. The Parties shall enter into negotiations on such proposed changes seventy-five (75) days after such Renegotiation Request Date.

 - (c) In the event that, notwithstanding, the good faith efforts of both Parties, they are unable to agree on terms and conditions of a new agreement, effective as of the expiration of this Agreement, then either Party may, beginning 135 days after the Renegotiation Request Date, file a petition for arbitration by the Commission pursuant to Section 252(b) of the Act.

- (d) The terms and conditions of this Agreement shall only continue in full force and effect until the effective date of the Commission's decision pursuant to any petition filed under Section 2(c) above (the "Arbitration Decision") if COVAD requests to renegotiate pursuant to Section 2(b) above; provided, however, that the prices, and, where feasible, any other terms and conditions of this Agreement shall be trued up to conform with the Arbitration Decision back to the date of expiration of the Term.
- (e) Nothing in this Section 2 shall be construed as a waiver by either Party of its right to appeal any decision of the Commission, including the Arbitration Decision.
- (f) Upon termination or expiration of this Agreement in accordance with this Section 2:
 - (i) each Party shall comply with its obligations set forth in paragraph (c) of Section 18 of the General Terms and Conditions of this Agreement;
 - (ii) each Party shall promptly pay all amounts (including any late payment charges or cancellation charges, if any) owed under this Agreement; and
 - (iii) each Party's obligations that by their terms continue in force and effect after termination or expiration of this Agreement (including, without limitation, indemnification obligations) shall survive termination or expiration of this Agreement.

3. **Transitional Support** Upon the termination or expiration of this Agreement, COVAD may itself provide or retain another vendor to provide unbundled Network Elements, or other access or services comparable to those furnished under the terms of this Agreement. BELL ATLANTIC agrees to cooperate with COVAD and to use commercially reasonable efforts to effect an orderly and efficient transition to COVAD or COVAD's new vendor, subject to the payment by COVAD to BELL ATLANTIC of the reasonable costs incurred in providing such cooperation.

4. **Good Faith Performance** In the performance of their obligations under this Agreement, the Parties shall act in good faith and consistently with the provisions of the Act and the applicable effective provisions of the Order. Except to the extent a different standard is expressly set forth in this Agreement, in which case such other standard shall apply, where notice, approval or similar action by a Party is permitted or required by any provision of this Agreement, (including, without limitation, the obligation of the Parties to further negotiate the

resolution of new or open issues under this Agreement) such notice, approval or similar action shall not be unreasonably delayed or withheld.

5. Option to Obtain Services, Unbundled Network Elements

- (a) If BELL ATLANTIC enters into an agreement approved by the Commission or the FCC pursuant to Section 252 of the Act which provides for the provision in the State of New York of arrangements covered in this Agreement to another requesting Telecommunications Carrier (the "Other Agreement"), BELL ATLANTIC shall make available to COVAD upon request, pursuant to section 252 (i) of the Act, such arrangements upon the same rates, terms and conditions as those provided in the Other Agreement.

If COVAD enters into an agreement with a Telecommunications Carrier approved by the Commission or the FCC pursuant to Section 252 of the Act with respect to services in the State of New York (the "Other COVAD Agreement"), then COVAD shall make available upon request the same interconnection, services and unbundled Network Elements to BELL ATLANTIC under the same terms and conditions as those provided in such Other COVAD Agreement to the full extent required by Section 252(i) of the Act.

- (b) Notwithstanding the terms and provisions of paragraph (a) of this Section 5, in the event that as a result of any decision, order or determination of any judicial or regulatory authority, it is determined that all or any portion of such paragraph (a) above is found invalid or unenforceable, the Parties agree to abide by such decision, order or determination to the extent paragraph (a) of this Section 5 conflicts with such decision, order or determination.

- 6. Responsibility of Each Party** Each Party has and hereby retains the right to exercise full control of and supervision over its own performance of its obligations under this Agreement, and retains full control over the employment, direction, compensation and discharge of all employees assisting in the performance of such obligations. Each Party will be solely responsible for all matters relating to payment of such employees, including compliance with social security taxes, withholding taxes and all other regulations governing such matters. Subject to the limitations on liability set forth in Section 9 of the General Terms and Conditions of this Agreement and except as otherwise expressly provided in this Agreement, each Party shall be responsible for (i) its own acts and performance of all obligations imposed by all applicable federal, state or local statutes, laws, rules, regulations, codes, orders, decisions, injunctions, judgments, awards and decrees (collectively, "Applicable Laws") in

connection with its activities, legal status and property, real or personal, and (ii) the acts of its own affiliates, employees, agents and contractors during the performance of that Party's obligations hereunder. Neither this Agreement, nor any actions taken by BELL ATLANTIC or COVAD in compliance with this Agreement, shall be deemed to create an agency, joint venture, or other relationship between COVAD and BELL ATLANTIC of any kind, other than that of purchaser and seller of services. Neither this Agreement, nor any actions taken by BELL ATLANTIC or COVAD in compliance with this Agreement, shall create a contractual, agency, or any other type of relationship or third party liability between BELL ATLANTIC and COVAD's end users or others.

7. Government Compliance

- 7.1 The provisions of this Agreement are subject in their entirety to the applicable provisions of the Act and any other orders, restrictions and requirements of governmental and regulatory authorities with competent jurisdiction over the subject matter thereof and, in the event of any direct conflict between the provisions of this Agreement and the requirements of such governmental and regulatory authorities, the requirements of such authorities shall prevail.
- 7.2 BELL ATLANTIC represents and COVAD acknowledges that BELL ATLANTIC is entering into this Agreement specifically in order to satisfy the obligations of BELL ATLANTIC as set forth in the Act and the Order.
- 7.3 In the event that any legislative, regulatory, judicial or other legal action materially affects any material terms of this Agreement or the rights or obligations of either COVAD or BELL ATLANTIC hereunder or the ability of COVAD or BELL ATLANTIC to perform any material provision hereof, the Parties shall renegotiate in good faith such affected provisions with a view toward agreeing to acceptable new terms as may be required or permitted as a result of such legislative, regulatory, judicial or other legal action.
- 7.4 Notwithstanding anything herein to the contrary, in the event that as a result of any decision, order or determination of any judicial or regulatory authority with jurisdiction over the subject matter hereof, it is determined that BELL ATLANTIC shall not be required to furnish any service or item or provide any benefit required to be furnished or provided to COVAD hereunder, then COVAD and BELL ATLANTIC shall promptly commence and conduct negotiations in good faith with a view toward agreeing to mutually acceptable new terms as may be required or permitted as a result of such decision, order or determination; provided, however, that BELL ATLANTIC expressly reserves all rights it may have

to discontinue any such service or item or benefit provided under this Agreement to the extent permitted by any such decision, order or determination and COVAD expressly reserves all rights it may have to oppose any such discontinuance by BELL ATLANTIC.

8. Regulatory Matters

8.1 Each Party shall reasonably cooperate with the other in obtaining and maintaining any required regulatory approvals for which the Party is responsible in connection with the performance of its obligations under this Agreement.

8.2 The Parties understand and agree that this Agreement will be filed with the Commission and may thereafter be filed with the FCC. Each Party covenants and agrees to fully support approval of this Agreement by the Commission or the FCC under Section 252 of the Act without modification, subject to the rights of the Parties to appeal or challenge arbitrated provisions or arbitration decisions. The Parties also reserve the right to seek regulatory relief and otherwise seek redress from each other regarding performance and implementation of this Agreement. In the event the Commission, FCC or any court rejects this Agreement in whole or in part, the Parties agree to meet and negotiate in good faith to arrive at a mutually acceptable modification of the rejected portion(s). If such new terms are not renegotiated within 30 days after such rejection, the dispute shall be referred to the Dispute Resolution process set forth in Section 16 of the General Terms and Conditions of this Agreement.

9. Liability and Indemnity

9.1 Indemnification

(a) With respect to all matters under this Agreement other than Local Services (which shall be governed by applicable Tariffs), to the extent not prohibited by Applicable Law, each Party (the "Indemnifying Party") shall indemnify and hold harmless the other Party ("Indemnified Party") from and against loss, cost, claim, liability, damage, and expense (including reasonable attorney's fees) to third parties for:

(i) damage to tangible personal property or for personal injury proximately caused by the negligence or willful misconduct of the Indemnifying Party, its employees, agents or contractors; and

- (ii) claims for libel, slander, infringement of copyright arising from the material transmitted over the Indemnified Party's facilities arising from the Indemnifying Party's own communications or the communications of such Indemnifying Party's Customers; and
 - (iii) claims for infringement of patents arising from combining the Indemnified Party's facilities or services with, or the using of the Indemnified Party's services or facilities in connection with, facilities of the Indemnifying Party.
- (b) The Indemnified Party will notify the Indemnifying Party promptly in writing of any claims, lawsuits, or demands by third parties for which the Indemnified Party alleges that the Indemnifying Party is responsible under this Section, and, if requested by the Indemnifying Party, will tender the defense of such claim, lawsuit or demand. In the event the Indemnifying Party does not promptly assume or diligently pursue the defense of the tendered action, then the Indemnified Party may proceed to defend or settle said action and the Indemnifying Party shall hold harmless the Indemnified Party from any loss, cost, liability, damage and expense. In the event the Party otherwise entitled to indemnification from the other elects to decline such indemnification, then the Party making such an election may, at its own expense, assume defense and settlement of the claim, lawsuit or demand. The Parties will cooperate in every reasonable manner with the defense or settlement of any claim, demand, or lawsuit.

9.2 Limitation of Liability

- (a) Except as otherwise provided in (i) Section 9.1 of the General Terms and Conditions of this Agreement, (ii) Section 11 of the General Terms and Conditions of this Agreement and (iii) Part III of this Agreement, no liability shall attach to either Party, its parents, subsidiaries, affiliates, agents, servants or employees for any cost, expense, claim, liability, damage, expense or other Loss in the absence of gross negligence or willful misconduct.
- (b) Except as otherwise expressly provided in (i) Section 9.1 of the General Terms and Conditions of this Agreement, (ii) Section 11 of the General Terms and Conditions of this Agreement and (iii) Part III of this Agreement, no Party shall be liable to the other

Party for any cost, expense, claim, liability, damage, expense or other Loss caused by the conduct of the other Party, the other Party's agents, servants, contractors or others acting in aid or concert with the other Party.

- (c) In no event shall either Party have any liability whatsoever to the other Party for any indirect, special, consequential, incidental or punitive damages, including, but not limited to loss of anticipated profits or revenue or other economic loss in connection with or arising from anything said, omitted or done hereunder (collectively, "Consequential Damages"), even if the other Party has been advised of the possibility of such damages.
- (d) Except as otherwise provided in (i) Section 9.1 of the General Terms and Conditions (ii) Section 11 of the General Terms and Conditions of this Agreement and (iii) Part III of this Agreement, each Party's liability to the other Party for any Loss relating to or arising out of any negligent act or omission in its performance of this Agreement, whether in contract or in tort, shall be limited to the amount that is or would have been charged to the other Party by such negligent or breaching Party for the specific service(s) or function(s) not performed or improperly performed, and only for the period of time such service or function was not performed or improperly performed.

10. Payment Terms, Disputed Amounts and Audits

10.1 [Intentionally Omitted]

10.2 Payment Terms

Except for alternate billed calls, and meet-point billed calls, each Party shall bill on a current basis all charges incurred by and credits due to the other Party under this Agreement attributable to services established, discontinued or performed during the preceding billing period. In addition, either Party may bill in advance charges for all services to be provided during the earning billing period except for charges associated with measured service usage which will be billed in arrears. The bill day (i.e., the billing date of a bill for a Party for services under this Agreement), the period of service each bill covers, and the payment date will be as follows:

- (a) Each Party will establish a bill day each month for the other Party's account. If payment is not received by the payment date, as set forth in (b) following, in immediately available funds, a late payment penalty will apply as set forth in (b) following.
- (b) All payment for bills dated as set forth in (a) preceding for service provided to one Party by the other are due within thirty-one (31) calendar days (payment date) unless the billed Party is able to establish that the bill was not timely received (i.e., at least 20 days prior to the payment date), in which case the payment date shall be twenty (20) calendar days from the receipt of the bill. All bills are payable in immediately available funds. If such payment date would cause payment to be due on a Saturday, Sunday or Legal Holiday, payment for such bills will be due from the billed Party as follows:
 - (i) If such payment date falls on a Sunday or on a Legal Holiday which is observed on a Monday, the payment date shall be the first non-Holiday day following such Sunday or Legal Holiday.
 - (ii) If such payment date falls on a Saturday or on a Legal Holiday which is observed on Tuesday, Wednesday, Thursday or Friday, the payment date shall be the last non-Holiday day preceding such Saturday or Legal Holiday.
 - (iii) Further, if any portion of the payment is received by the billing Party after the payment date, or if any portion of the payment is received by the billing Party in funds which are not immediately available to the billing Party, then a late penalty shall be due to the billing Party. The late payment penalty shall be the portion of the payment not received by the payment date or not immediately

available times a late factor. The late factor shall be the lesser of:

- (x) The highest interest rate (in decimal value) which may be allowed by law for commercial transactions, for the number of days from the payment date to and including the date that the billed Party, actually makes the payment to the billing Party, or
- (y) 0.0005 per day, simple interest, for the number of days from the payment date to and including the date that the billed Party actually makes the payment to the billing Party.

10.3 Disputed Amounts

In the event that a billing dispute occurs concerning any charges billed to the billed Party by the billing Party the following provisions will apply.

- (a) The first day of the dispute shall be the date on which the billed Party furnishes in writing the billing Party with the account number under which the bill has been rendered, the date of the bill and the specific items on the bill being disputed.
- (b) If the Parties are unable to resolve the issues related to the disputed amounts in the normal course of business within ninety (90) days after delivery to the billing Party of notice of the disputed amounts, each of the Parties shall appoint a designated representative who has authority to settle the dispute and who is at a higher level of management than the persons with direct responsibility for administration of this Agreement. The designated representatives shall meet as often as they reasonably deem necessary in order to discuss the dispute and negotiate in good faith in an effort to resolve such dispute. The specific format for such discussions will be left to the discretion of the designated representatives, however all reasonable requests for relevant information made by one Party to the other Party shall be honored.
- (c) If the Parties are unable to resolve issues related to the disputed amounts within forty-five (45) days after the Parties' appointment of designated representatives pursuant to paragraph (b) above, then the matter shall be referred for resolution pursuant to Section 16 of the General Terms and Conditions of this Agreement.
- (d) The Parties agree that all negotiations pursuant to this Section 10.3 with respect to disputed amounts shall remain confidential and shall be treated as compromise and settlement negotiations for purposes of the

Federal Rules of Evidence and state rules of evidence.

- (e) If a billing dispute is resolved in favor of the billing Party, any payments withheld pending resolution of the dispute shall be subject to the late payment penalty as set forth in paragraph 10.2 (b) (iii) above. Further, the billed Party will not receive a disputed amount penalty credit and/or a late payment penalty credit.
- (f) If a billed Party disputes a bill within three months of the payment date and pays the total billed amount on or before the payment date, and the billing dispute is resolved in favor of the billed Party, the billed Party will receive a credit for a disputed amount penalty from the billing Party for the period starting with the date of payment and ending on the date of resolution. The credit for a disputed amount penalty shall be the following:

The disputed amount penalty shall be calculated by multiplying that portion of the disputed amount paid and resolved in the billed Party's favor times the lesser of:

 - (i) The highest interest rate (in decimal value) which may be allowed by law for commercial transactions, for the number of days from the first date to and including the last date of the period involved, or
 - (ii) 0.0005 per day for the number of days from the first date to and including the last date of the period involved.
- (g) If the billed Party disputes a bill within three months of the payment date and pays the total billed amount after the payment date and the billing dispute is resolved in favor of the billed Party, the billed Party will receive a credit for a disputed amount penalty from the billing Party for the period starting with the date of payment and ending on the date of resolution. The credit for a disputed amount penalty shall be as set forth following. In addition, the late payment penalty applied to the disputed amount resolved in the billed Party's favor as set forth in paragraph 10.2(b)(iii) preceding will be credited.
- (h) If the billed Party disputes a bill within three months of the payment date and does not pay the disputed amount or does not pay the billed amount (i.e., the non-disputed and disputed amount), and the billing dispute is resolved in favor of the billed Party, the billed Party will not receive a credit for a disputed amount penalty from the billing Party. The late payment penalty applied to the disputed amount resolved in the billing

Party's favor as set forth in paragraph 10.2(b)(iii) preceding will not be credited.

- (i) If a billed Party disputes a bill after three months from the payment date and pays the total billed amount on or before the dispute date or after the dispute date but prior to the date of resolution, and the billing dispute is resolved in favor of the billed Party, the billed Party will receive a credit for a disputed amount penalty from the billing Party for the period starting with the date of dispute (if the payment was received before or on the dispute date) or the date of payment (if the payment was received after the dispute date) and ending on the date of resolution. The credit for a disputed amount penalty shall be as set forth following. The billed Party will not receive a credit for the late payment penalty applied to the disputed amount resolved in the billed Party's favor if the payment was received on or before the dispute date. If the payment was received after the dispute date but prior to the date of resolution, the billed Party will receive a credit for a late payment penalty applied to the disputed amount resolved in the billed Party's favor times a late payment penalty factor for the period starting with the date of dispute and ending on the date of payment. The penalty factor shall be as set forth in paragraph 10.2(b)(iii) preceding.
- (j) If the billed Party disputes a bill after three months from the payment date and does not pay the disputed amount or does not pay the billed amount (i.e., the non-disputed amount and disputed amount) and the billing dispute is resolved in favor of the billed Party, the billed Party will not receive a credit for a disputed amount penalty from the billing Party. The billed Party will receive a credit for the late payment penalty applied to the disputed amount resolved in the billed Party's favor times a late payment penalty factor for the period starting with the date of dispute and ending on the date of resolution. The penalty factor shall be as set forth in paragraph 10.2(b)(iii) preceding.
- (k) Adjustments for the quantities of services established or discontinued in any billing period will be prorated to the number of days or major fraction of days based on a thirty (30) day month. The billing Party will, upon request and if available, furnish to the billed Party such detailed information as may reasonably be required for verification of any bill.
- (l) When a rate as set forth in this Agreement is shown to more than two decimal places, the charges will be determined using the rate shown. The resulting amount will then be rounded to the nearest penny (i.e., rounded to two decimal places).

10.4 Audits and Inspections

- (a) Subject to the terms and conditions of this Section 10.4, the restrictions set forth in Section 18 of the General Terms and Conditions and the reasonable security requirements of each Party and except as may be otherwise specifically provided in this Agreement, each Party (the "Auditing Party") may audit the other Party's (the "Audited Party") books, records and other documents which relate solely to the Parties' billing to the other Party under this Agreement once each year at the conclusion of each calendar year, in order to evaluate the accuracy of such other Party's billing and invoicing. The Parties may employ other persons or firms for this purpose. Such audit shall take place at a time and place agreed to by the Parties no later than thirty (30) days after notice thereof to such other Party.
- (b) Each Audited Party shall promptly correct any billing error that is revealed in an audit, including reimbursing any overpayment in the form of a credit to the Auditing Party on the invoice for the first full billing cycle after the Parties have agreed upon the accuracy of the audit results. Any disputes concerning audit results shall be resolved pursuant to the procedures described in Section 16 of the General Terms and Conditions of this Agreement.
- (c) Each Audited Party shall cooperate fully in any such audit, providing reasonable access to any and all appropriate employees and relevant books, records and other documents reasonably necessary to assess the accuracy of its bills.
- (d) Each Auditing Party may perform a single additional audit of the Audited Party's relevant books, records and documents during any calendar year if the previous audit uncovered uncorrected net variances or errors in invoices in favor of the Audited Party having an aggregate value (except for Local Services purchases) of not less than two percent (2%) of the total amount payable by the Auditing Party during the period covered by the audit.
- (e) All audits shall be conducted at the sole cost and expense of the Auditing Party.
- (f) Upon (i) the discovery by either Party of overcharges not previously reimbursed to the other Party or underpayments by a Party or (ii) the resolution of disputed audits, each Party shall

promptly reimburse or pay to the Party entitled thereto the amount of any overpayment or underpayment, together with interest thereon at a rate per month equal to the lesser of 1.5% or the maximum permitted legal rate of interest for the number of days from the date such Party received such overpayment or, in the case of an underpayment, should have received such payment through but excluding the date such reimbursement or payment is made. In no event, however, shall interest be assessed on any previously assessed or accrued late payment charges.

10.5 Alternate Billing to Third Numbers

10.5.1 Intentionally Omitted

10.5.2 Intentionally Omitted

10.5.3 Intentionally Omitted

10.5.4 Intentionally Omitted

10.5.5. Alternate Billed Calls.

BELL ATLANTIC will use a BELL ATLANTIC territory intraregion Alternate Billed Call clearinghouse (the "Clearinghouse") for settling Alternate Billed Calls for facility-based and unbundled Network Element purposes. BELL ATLANTIC shall provide usage records for Alternate Billed Calls directly to COVAD with a report to the Clearinghouse. COVAD agrees that it will promptly pay to the Clearinghouse all amounts billed by the Clearinghouse on behalf of BELL ATLANTIC for Alternate Billed Calls. COVAD shall be entitled to a billing and collection fee as specified in Part IV for billing Alternate Billed Calls to COVAD customers. Such billing and collection fee shall be deducted by the Clearinghouse from the amounts owed by COVAD to BELL ATLANTIC and the bill provided to COVAD by the Clearinghouse shall reflect the net amount due from COVAD.

COVAD will transmit and settle Alternate Billed calls directly with BELL ATLANTIC or its agent at which time the Billing and Collection fee will be as specified in Part IV for Alternate Billed calls.

10.6 Reciprocal Compensation

- (a) Reciprocal Compensation only applies to the transport and termination of Reciprocal Compensation Traffic.
- (b) The Parties shall compensate each other for transport and termination of Reciprocal Compensation Traffic, based on actual usage, at the rates set forth in Part IV hereof.
- (c) The Reciprocal Compensation arrangements set forth in this Agreement are not applicable to Switched Exchange Access Service, including intraLATA calls originated on a third-party carrier's network on a 1+ presubscribed basis or a casual dialed (10XXX or 101XXXX) basis. All Switched Exchange Access Service and all Toll Traffic shall continue to be governed by the terms and conditions of the applicable federal and state Tariffs. Notwithstanding any legislative, regulatory, judicial or other legal action, the Parties agree that the Reciprocal Compensation arrangements contained in this subsection 10.6 shall not apply to traffic handed off from one Party to the other Party, within a BELL ATLANTIC intraLATA calling area, for delivery to an Internet Service Provider for carriage over the Internet ("ISP Traffic"). To the extent that either Party is unable to measure the volume of ISP Traffic, the Parties agree to work cooperatively to estimate such traffic volume.
- (d) When either Party delivers seven (7) or ten (10) digit translated intraLATA 800/888 service to the other Party for termination, where the originating Party uses its own switch (*i.e.*, not utilizing unbundled switching from the terminating Party), the originating Party shall provide the terminating Party with customer billing records in industry standard format (EMR) if required by the terminating Party. Where the originating Party utilizes unbundled switching from the terminating Party, the Party with recording capability will provide such records. Where the originating Party uses its own switch (not utilizing unbundled switching) to originate the call, the originating Party may bill the terminating Party for the delivery of the traffic at Reciprocal Compensation rates. The terminating Party may not bill the originating Party for Reciprocal Compensation under this Agreement, except

where the originating Party fails to provide the terminating Party with useable EMR records in a timely manner. The originating Party shall bear the entire cost of any systems development and production of such records; provided that the terminating Party that is providing the 800/888 service shall pay for each record provided by the originating Party at the reciprocal record exchange rate set forth in Part IV hereof. If the originating Party performs the 800 database query for the terminating Party, the originating Party may charge the terminating Party for such a query at the rate set forth in Part IV hereof.

- (e) Except for Reciprocal Compensation Traffic, each Party shall charge the other Party its effective applicable tariffed IntraLATA switched access rates for the transport and termination of all IntraLATA Toll Traffic.
- (f) The rates for termination of Reciprocal Compensation Traffic are set forth in Part IV.

11. Installation Intervals and Credits

11.1 Installation Intervals

BELL ATLANTIC shall provision the unbundled Network Elements identified below in accordance with the installation intervals specified herein, provided, however, that in no event shall BELL ATLANTIC be obligated to provide intervals that are more favorable than BELL ATLANTIC extends to its own customers for comparable services. In the event that an interval BELL ATLANTIC extends to its own customers for a comparable service exceeds the interval specified below, BELL ATLANTIC shall notify COVAD in writing of the interval that BELL ATLANTIC extends to its own customers for that comparable service (the "parity interval"). Ten (10) days after receipt of such notice, the parity interval shall apply to subsequent orders placed by COVAD for the comparable element for which intervals are specified in this Section 11, notwithstanding the intervals specified in Section 11.1(a)-(c) below.

After receipt of such notice, and notwithstanding Section 11.5 below, Covad may, at any time and at its sole discretion, elect to waive its rights to credits pursuant to this Section 11 and may seek other applicable intervals and remedies that may result from PSC or FCC

proceedings for any failure by Bell Atlantic to timely provide any unbundled Network Element specified in this Section 11.

- a) In every instance where facilities exist and COVAD orders less than ten (10) 2-Wire ISDN-Compatible Digital Loops or less than ten (10) 4-Wire 64 Kbps Digital Loops, as described in Part II, Section 2.9.1 (c) and (d), from BELL ATLANTIC, BELL ATLANTIC shall provide to COVAD such loops within ten (10) business days from BELL ATLANTIC's receipt of a complete and accurate order from COVAD.
- b) Unless otherwise mutually agreed, Interoffice Transmission Facilities ("IOF"), excluding SONET, shall be provided to COVAD within thirty (30) calendar days from BELL ATLANTIC's receipt of a complete and accurate order from COVAD, subject to the availability of facilities. The installation interval for the provision of IOF on or using SONET technologies shall be negotiated by the Parties in good faith.
- (c) To the extent ADSL-Compatible and/or HDSL-Compatible Loops become available under the terms set forth in Part II, Section 2.9.1 (g), BELL ATLANTIC and COVAD agree to negotiate installation intervals for such unbundled Network Elements after the successful completion of an Operational Trial as described in Part II, Section 2.9.1(g). The Parties shall negotiate in good faith to establish such installation intervals and associated credit provisions within sixty (60) days of the date on which such loops are first provisioned by BELL ATLANTIC pursuant to Part II, Section 2.9.1(g).

11.2 Specified Performance Breach

If BELL ATLANTIC's provision of an unbundled Network Element identified in Section 11.1 above, exceeds the installation interval set forth in that Section, BELL ATLANTIC shall issue credits to COVAD, in accordance with and subject to the terms and conditions set forth in this Section 11.

11.3 Credits

COVAD and BELL ATLANTIC agree and acknowledge that: (i) the credits are not a penalty and have been determined based upon the facts and circumstances known to COVAD and BELL ATLANTIC at the time of the negotiation and the execution of this Agreement, with due regard given to the performance expectations of each Party; and (ii) COVAD shall not be required to provide any proof of its injury from any failure by BELL ATLANTIC to achieve the installation interval as a condition precedent to issuance of the credit. Notwithstanding (ii)

above, COVAD upon BELL ATLANTIC's request shall provide any information reasonably requested by BELL ATLANTIC to enable BELL ATLANTIC to determine whether a credit is payable, including information for any particular unbundled Network Element for which COVAD asserts BELL ATLANTIC failed to meet the installation interval set forth in Section 11.1 of the General Terms and Conditions of this Agreement. Credits will apply as follows, subject to the foregoing and to the limitations set forth in Section 11.4 below:

- (a) 2-Wire ISDN-Compatible Digital Loops 4-Wire 64 Kbps Digital Loops, ADSL-Compatible Loops, and HDSL-Compatible Loops.
In the event that BELL ATLANTIC fails to provide a 2-Wire ISDN Compatible Digital Loop, a 4-Wire 64 Kbps Digital Loop, or an ADSL- or HDSL-Compatible Loop to COVAD within the installation interval set forth in Section 11.1 (a) or (c), BELL ATLANTIC shall credit COVAD twenty five percent (25%) of the applicable installation nonrecurring charges. For every business day beyond the installation interval specified in Section 11.1(a) or (c), that BELL ATLANTIC does not provide such loops BELL ATLANTIC shall credit COVAD with 1/10th of the installation nonrecurring charge for each such loop. Notwithstanding the foregoing, at no time shall the maximum credit exceed the full nonrecurring charge applicable to the installation of such loops.
- (b) Interoffice Transmission Facilities. If BELL ATLANTIC fails to install IOF within the installation interval set forth in Section 11.1(b), then for every business day that BELL ATLANTIC does not provide IOF services beyond a thirty-five (35) day period, BELL ATLANTIC shall credit COVAD with 1/20th of the applicable installation nonrecurring charge for such service. Notwithstanding the foregoing, at no time shall the maximum credit exceed the full nonrecurring charge applicable to the installation of such service.

11.4 Limitations

BELL ATLANTIC shall not be liable for credits specified in Section 11.3 where:

- a) BELL ATLANTIC's failure to meet the installation interval is caused, directly or indirectly, by a Delaying Event. A "Delaying Event" means (i) a failure by COVAD to perform any of its obligations set forth in this Agreement; (ii) any delay, act or failure to act by COVAD or its customer, agent, vendor, affiliate, representative or subcontractor; (iii) any Force Majeure Event; or (iv) such other delay, act or failure to act upon which the Parties may agree. Where BELL ATLANTIC is unable to provision an unbundled Network Element because of a Delaying Event, BELL ATLANTIC shall assign a new installation interval subject to the terms set forth in Section 11.1 and Section 11.3, above, this Section 11.4, and Section 11.5 below;
- b) For any order for Local Loops or IOF, where COVAD has requested a date due or other installation interval different (later or earlier) from those specified in Section 11.1 (a) and (b);
- c) COVAD has submitted orders for Local Loops in excess of (i) 3000 in any one month, (ii) 200 in any one day, (iii) 150 in any one Central Office in any one day, or (iv) 30 in any one hour. In such event, credits will apply only to the first (w) 3000 orders submitted in that particular month, (x) 200 orders submitted in that particular day; (y) 150 orders submitted in that particular Central Office on that particular day; or (z) 30 orders submitted in that particular hour;
- d) COVAD has submitted orders for Local Loops or IOF that exceed the forecast provided by COVAD by greater than five percent (5%) by type and location. In such event, credits will apply only to orders up to the forecasted amount; and/or
- e) COVAD has not submitted the order(s) for Local Loops or IOF through the standard electronic interface, provided that BELL ATLANTIC has made available to COVAD a standard electronic interface pursuant to this Agreement.

11.5 Sole Remedy

In the absence of gross negligence or willful misconduct, the credits described herein shall be the sole and exclusive remedy available for any failure by BELL ATLANTIC to provide the unbundled Network Elements in accordance with this Section 11 regardless of the existence or availability of any other remedy, procedure or process available to COVAD at law or equity, and shall apply irrespective of any other determinations made with respect to other carriers in PSC Case No. 97-C-0139.

12. OSS/Electronic Interfaces

For unbundled Network Elements, BELL ATLANTIC will provide nondiscriminatory access to OSS functions for preordering, ordering, provisioning, maintenance and repair, and billing as required by the Act, the Order and other Applicable Law.

13. Operations Plan and Implementation Team The Parties agree to an Implementation Plan as set forth in Attachment 2 to this Agreement.
14. Force Majeure
 - (a) Neither Party shall be liable for any delay or failure in performance of any part of this Agreement (other than an obligation to make money payments) from any cause beyond its reasonable control and without its fault or negligence including, without limitation, acts of nature, acts of civil or military authority, government regulations, embargoes, epidemics, terrorist acts, riots, insurrections, fires, explosions, earthquakes, nuclear accidents, floods, work stoppages, strikes, equipment failure, power blackouts, volcanic action, other major environmental disturbances, unusually severe weather conditions, inability to secure products or services of other persons or transportation facilities, or acts or omissions of transportation carriers (each, a "Force Majeure Event"). If any Force Majeure Event occurs, the Party delayed or unable to perform shall give prompt notice to the other Party and shall take all reasonable steps to mitigate the effects of such Force Majeure Event. During the pendency of the Force Majeure Event, the duties of the Parties under this Agreement affected by the Force Majeure Event shall be abated and, upon cessation of such Force Majeure Event, shall resume as promptly as reasonably practicable, without liability thereafter.
 - (b) Notwithstanding paragraph (a) of this Section 14, no delay or other failure to perform shall be excused pursuant to this Section 14 by the acts or omissions of a Party's subcontractors, material men, suppliers or other third persons providing products or services to such Party unless such acts or omissions are themselves the product of a Force Majeure Event, or unless such delay or failure and the consequences thereof are beyond the reasonable control and without the fault or negligence of the Party claiming excusable delay or other failure to perform.
15. Certain State and Local Taxes Each Party purchasing services hereunder shall pay or otherwise be responsible for all federal, state, or local sales, use, excise, gross receipts, transaction or similar taxes, fees or surcharges levied against or upon such purchasing Party (or the providing Party when such providing Party is permitted to pass along to the purchasing Party such taxes,

fees or surcharges), except for any tax on either Party's corporate existence, status or income (other than income taxes included in rates through the computation of carrying charge factors). Whenever possible, these amounts shall be billed as a separate item on the invoice. To the extent a sale is claimed to be qualified for resale tax exemption, the purchasing Party shall furnish the providing Party a proper resale tax exemption certificate as authorized or required by statute or regulation by the jurisdiction providing said resale tax exemption. Failure to timely provide said resale tax exemption certificate will result in no exemption being available to the purchasing Party.

16. Dispute Resolution

16.1 General

Except for any matters related to BELL ATLANTIC's compliance with the FCC Merger Order in the Application of BELL ATLANTIC Corporation, Transferee, For Consent to Transfer Control of BELL ATLANTIC Corporation and its Subsidiaries, NSD-L-96-10, Memorandum Opinion and Order (August 14, 1997) ("the FCC Merger Order") (including but not limited to any payment option established pursuant to Section 17A of the General Terms and Conditions of this Agreement), dispute resolution under the procedures provided in this Section 16 shall be the primary remedy for all disputes between BELL ATLANTIC and COVAD directly arising out of this Agreement or its breach.

If, for any reason, certain claims or disputes are deemed to be non-arbitrable, the non-arbitrability of those claims or disputes shall not determine the arbitrability of any other claims or disputes.

Nothing in this Section 16 shall limit the right of either BELL ATLANTIC or COVAD to obtain provisional remedies (including injunctive relief) from a court before, during or after the pendency of any arbitration proceeding brought pursuant to this Section 16. However, once a decision is reached by the arbitrator, such decision shall supersede any provisional remedy.

If, for any reason, the Commission or any other federal agency of competent jurisdiction exercises jurisdiction over and decides any dispute arising out of this Agreement and, as a result, a claim is adjudicated in both an agency proceeding and an arbitration proceeding under this Section 16, the agency ruling shall be binding upon the Parties, to the extent allowed by law.

16.2 Inter-Company Review Board:

- (1) The Parties to this Agreement shall establish an Inter-Company Review Board consisting of at least one representative from each Party at the managing director or above level (or such lower level as the Parties agree) to assist in the resolution of disputes between BELL ATLANTIC and COVAD.

- (a) Each Party must designate its initial representative to the Inter-Company Review Board within 15 days of the Effective Date of this Agreement.
- (b) The Parties may change their designee, or select an alternative designee, as required or deemed appropriate, without notice.

16.3 Non-Service Affecting Disputes:

If a non-service affecting dispute arises between BELL ATLANTIC and COVAD during the term of the Agreement, the following process shall be followed to resolve such dispute. In the event the Parties, in good faith, do not agree that a non-service affecting dispute exists, the dispute shall be assumed to be a service affecting dispute and the process for resolving a service affecting dispute, as described below, shall be followed.

(1) Informal Negotiation of Non-Service Affecting Dispute.

If the parties have a non-service affecting dispute either Party may initiate the procedures set forth herein by providing notice of the existence of a non-service affecting dispute as set forth in Section 17. The petitioning party shall also serve the Commission and the Inter-Company Review Board with a copy of the notice.

- (a) The Parties shall have an initial 30 day period beginning from the date on which either Party has provided written notice to the other Party identifying the existence of a non-service affecting dispute within which to resolve the dispute themselves, without mediation or arbitration as provided below.
- (b) During the 30 day period referenced in subsection (a), the Parties, through the Inter-Company Review Board, shall make a reasonable effort to meet as often as necessary but not less than one time each week in an effort to resolve a dispute.
- (c) The Parties may also mutually agree to other informal resolution processes for specific circumstances, including, but not limited to commercial mediation or arbitration.

(2) Formal Mediation or Arbitration of Non-Service Affecting Dispute.

If the Inter-Company Review Board is unable to resolve a non-service affecting dispute within thirty days (or such other period agreed to in writing by the Parties) either Party may petition the Commission to request mediation. If agreement cannot be reached through mediation, either Party may then file a petition for commercial arbitration pursuant to the

Commercial Arbitration Rules of the American Arbitration Association.

- (a) A request for mediation shall be submitted in writing to the Commission, with a copy served on the other Party pursuant to Section 17.
- (b) The period of mediation shall be 30 days commencing on the date of filing of such petition for mediation. Such petition shall include a request to the Commission to choose a mediator within the first 10 days of such 30 day period, and the mediation shall be conducted by a mediator designated by the Commission. The Commission may assign a staff person or a professional mediator to conduct the mediation. The Parties shall cooperate in good faith with the mediator to resolve the dispute within such 30 day period. If, at any date following the 20th day of such 30 day period, the Parties have not resolved their dispute, the Parties may request the mediator formally declare a deadlock.
- (c) Following the earlier to occur of (i) expiration of the 30 day mediation period without resolution of the dispute between the Parties or (ii) formal declaration of a deadlock by the mediator as contemplated in preceding paragraph (b), either Party may petition for arbitration by a single arbitrator pursuant to the Commercial Arbitration Rules of the American Arbitration Association. This petition for arbitration should include a comprehensive explanation of the dispute (e.g., unresolved issues, areas of agreement, stipulations of fact), as well as all relevant correspondence exchanged during negotiations or mediation. The petitioning Party shall provide a copy of the petition to the other Party on the same day that the petition for arbitration is filed. The other Party shall assent to such petition for arbitration.
- (d) The rules set forth in this subsection and the rules of the American Arbitration Association ("AAA") shall govern all arbitration proceedings initiated pursuant to this Section 16; however, such arbitration proceedings shall not be conducted under the auspices of the AAA unless the Parties mutually agree. Where any of the rules set forth herein conflict with the rules of the AAA, the rules set forth in this Section 16 shall prevail.
- (e) To the extent possible, within ten (10) days of the filing of the petition for arbitration, the Parties shall appoint an arbitrator upon mutual agreement to resolve the dispute.
- (f) Discovery shall be controlled by the arbitrator. The arbitrator shall have the power to award any remedy or relief that a court with jurisdiction over this Agreement could order or grant, including,

without limitation, the awarding of damages, pre-judgment interest, specific performance of any obligation created under the Agreement, issuance of an injunction, or imposition of sanctions for abuse or frustration of the arbitration process except as limited by Sections 9 and 11 of the General Terms and Conditions and Part III of this Agreement. The arbitrator shall not have the authority to limit, expand, or otherwise modify the terms of this Agreement.

- (g) The arbitration hearing shall be commenced within sixty (60) days of the petition for arbitration. The arbitrator shall issue in writing and serve his or her decision and award on the Parties within 20 business days of the close of the arbitration hearing. The times specified in this subsection may be extended upon mutual agreement of the Parties or by the arbitrator upon a showing of good cause by one Party.
- (h) Within thirty (30) days of the decision and award, the arbitrator's decision must be submitted to the Commission for review. Each Party must also submit its position on the award and statement as to whether the Party agrees to be bound by it or seeks to challenge it. The Commission will determine whether to review the dispute within fifteen (15) days of the date of receipt of the decision submitted for review. If the Commission does not exercise its jurisdiction within fifteen (15) days of receipt, the arbitrator's decision and award shall be final and binding on the Parties, except as provided below. Judgment upon the award rendered by the arbitrator may be entered in any court having jurisdiction thereof. Either Party may apply to the United States District Court for the district in which the hearing occurred for an order enforcing the decision.
- (i) A decision of the arbitrator shall not be final in the event the dispute concerns the misappropriation or use of intellectual property rights of a Party, including, but not limited to, the use of the trademark, tradename, trade dress or service mark of a Party, and the decision and award is appealed by a Party to a federal or state court with jurisdiction over the dispute.
- (j) Each Party agrees that any permitted appeal must be commenced within thirty (30) days after the arbitrator's decision in the arbitration proceeding becomes final and binding.
- (k) In the event an agency or court agrees to hear the matter on appeal, a Party must comply with the results of the arbitration

process during the appeal process, unless a stay is granted.

- (l) Except as provided below, each Party shall bear its own costs of these procedures. The Parties shall equally split the fees of the arbitration and the arbitrator. However, if in the arbitrator's judgment, one Party's claim is frivolous, then the arbitrator may determine that such Party should bear such expense.

16.4 Service Affecting Disputes:

If a service affecting dispute arises between BELL ATLANTIC and COVAD during the term of the Agreement, the following process shall be followed to resolve such dispute. Any disputes over a matter that directly affects the ability of a Party to provide timely services to its customers shall be considered a service affecting dispute. The Parties may mutually agree to resolve service affecting disputes in accordance with the procedures set forth in Section 16.3 for non-service affecting disputes. However, in the sole discretion of the Party identifying the existence of the service affecting dispute, said dispute may be resolved in accordance with the general procedures/timeframes for a non-service affecting dispute, as described above. The Parties agree that disputes regarding the applicability or provision of credits under Section 11 of the General Terms and Conditions and Part III of this Agreement shall not constitute service affecting disputes.

(1) Informal Negotiation of Service Affecting Dispute.

If the Parties have a service affecting dispute either Party may initiate the procedures set forth herein by providing notice of the existence of a service affecting dispute as set forth in Section 17. The Parties shall have an initial seven business day period beginning from the date on which either Party has provided written notice to the other Party identifying the existence of a service affecting dispute and seeking to resolve it, within which to resolve the dispute themselves, without mediation or arbitration as provided below, except as set forth in subsection (b) below.

(a) The Parties to this Agreement shall submit any service affecting dispute between BELL ATLANTIC and COVAD for resolution to the Inter-Company Review Board. The Parties shall make a reasonable effort to meet as often as necessary but not less than once in an effort to resolve the dispute. The specific format for such discussions will be left to the discretion of the designated representatives, however, all reasonable requests for relevant information made by one Party to the other Party shall be honored.

(b) The Parties may also mutually agree to other informal resolution processes for specific circumstances, including, but not limited to

commercial mediation or arbitration.

- (2) Formal Arbitration of Service Affecting Dispute If the Inter-Company Review Board is unable to resolve a service affecting dispute within seven business days (or such other period agreed to in writing by the Parties) either Party may petition for arbitration to resolve the dispute pursuant to paragraph 16.3, subsection (2)(c)-(l) as modified by this subparagraph. A dispute will be deemed submitted to the Inter-Company Review Board on the date a Party requests Inter-Company Review Board action in writing, transmitted by facsimile and confirmed. A Party's petition for arbitration may be in letter or memorandum form and must specifically describe the action or inaction of the other Party in dispute and identify with particularity how the Party's service to its Customers is affected. To the extent reasonable, and technically and operationally feasible, the Party against whom the complaint has been made, shall take immediate remedial action to correct the service affecting condition, without prejudice to its position on the merits of the dispute or its right to recover any costs incurred in implementing an interim solution. The arbitration hearing shall be commenced within thirty (30) days of the petition for expedited arbitration. The hearing will be limited to four days, with each Party allocated no more than two days, including cross-examination by the other Party, to present its evidence and arguments. At the arbitrator's discretion and for extraordinary reasons, including the need for extensive cross-examination, the arbitrator may allocate more time for the hearing. The arbitrator shall issue in writing and serve his or her decision and award on the Parties within five (5) business days of the close of the arbitration hearings or receipt of the hearing transcript, whichever is later. The Parties shall take actions necessary to implement the decision and award of the arbitrator immediately upon receipt of the arbitrator's decision. The Parties shall submit the decision and award of the arbitrator, along with each Party's position on the award and statement as to whether the Party agrees to be bound by it or seek to challenge it, to the Commission within three (3) days of receipt of the arbitrator's award and decision. The Commission will determine whether to review the dispute within seven (7) days of receipt. If the Commission does not exercise its jurisdiction in seven (7) days, the arbitrator's decision and award shall be final and binding on the Parties, except as provided in Section 16.2, subsection (2).

16.4 Confidentiality

- (1) BELL ATLANTIC, COVAD, and the mediator or arbitrator will treat the mediation or arbitration proceedings, including the hearings and conferences, discovery, or other related events, as confidential, except as

necessary in connection with a judicial challenge to, or enforcement of, an award, or unless otherwise required by an order or lawful process of a court or governmental body.

- (2) In order to maintain the privacy of all mediation or arbitration conferences and hearings, the mediator or arbitrator shall have the power to require the exclusion of any person, other than a Party, counsel thereto, or other essential persons.
- (3) To the extent that any information or materials disclosed in the course of mediation or arbitration proceedings contain proprietary, trade secret or confidential information of either Party, it shall be safeguarded in accordance with an appropriate agreement for the protection of proprietary, trade secret or confidential information that the Parties agree to negotiate. However, nothing in such negotiated agreement shall be construed to prevent either Party from disclosing the other Party's information to the mediator or arbitrator in connection with or in anticipation of mediation or arbitration proceedings. In addition, the arbitrator may issue orders to protect the confidentiality of proprietary information, trade secrets, or other sensitive information in the event the Parties cannot agree upon an agreement to govern the handling of such information.

17. **Notices** Any notices or other communications required or permitted to be given or delivered under this Agreement shall be in hard-copy writing (unless otherwise specifically provided herein) and shall be sufficiently given if (a) delivered personally, (b) delivered by prepaid overnight express service or (c) delivered by confirmed telecopier transmission with a copy delivered thereafter in the manner set forth in (a) or (b) above, to the following (unless otherwise specifically required by this Agreement to be delivered by other means or to another representative or point of contact and except for notices required in the ordinary course of business):

If to COVAD:

COVAD Communications Company
3650 Bassett Street
Santa Clara, CA 95054

Attn: General Counsel

With a copy of each notice relating to an action, suit proceeding or claim to be sent simultaneously to:

COVAD Communications Company
3650 Bassett Street
Santa Clara, CA 95054

Attn: Chief Executive Officer
Telecopier: (408) 490-4501

If to Bell Atlantic:

BELL ATLANTIC
1095 Avenue of the Americas
40th Floor
New York, NY 10036
Attention: General Counsel
Telecopier: (212) 597-2560

With a copy of each notice relating to an action, suit proceeding or claim to be sent simultaneously to:

BELL ATLANTIC
1095 Avenue of the Americas
40th Floor
New York, NY 10036
Attention: President - Telecom Industry Services
Telecopier: (212) 597-2560

Either Party may unilaterally change its designated representative and/or address for the receipt of notices by giving seven (7) days' prior written notice to the other Party in compliance with this Section. Any notice or other communication shall be deemed given when received.

- 17A. **Non-Waiver.** Nothing in this Agreement shall constitute a waiver by COVAD of any rights it may have under the FCC Order in the Application of BELL ATLANTIC Corporation, Transferee, For Consent to Transfer Control of BELL ATLANTIC Corporation and its Subsidiaries, NSD-L-96-10, Memorandum Opinion and Order (August 14, 1997) ("the FCC Merger Order"). Any such rights under the FCC Merger Order shall supplement COVAD's rights under this Agreement.

Pursuant to the FCC Merger Order, BELL ATLANTIC will provide COVAD with an installment payment option as outlined in the letter to the Commission dated November 12, 1997 and contained in Appendix A to the General Terms and Conditions or an alternative equally acceptable to BELL ATLANTIC. The Parties agree to continue discussions to see if they can establish a reasonable alternative that is agreeable to both Parties. If the Parties agree to the terms and conditions of such a payment option, then the Parties agree to amend this Agreement to incorporate such terms and conditions. If BELL ATLANTIC proposes any future installment payment option that BELL ATLANTIC makes generally available, COVAD may adopt such option and the Parties will amend this Agreement to incorporate such terms and conditions.

18. Confidentiality

- (a) Any information such as specifications, drawings, sketches, business information, forecasts, models, samples, data, computer programs and other software and documentation of one Party (a "Disclosing Party") that is furnished or made available or otherwise disclosed to the other Party or any of its employees, contractors, agents or Affiliates (its "Representatives" and, together with a Party, a "Receiving Party") pursuant to this Agreement (such information, other than customer proprietary network information, as defined in Section 222(f)(1) of the Act, being hereinafter collectively referred to as "Proprietary Information") shall be deemed the property of the Disclosing Party. Proprietary Information, if written, shall be marked "Confidential" or "Proprietary" or by other similar notice, and, if oral or visual, shall be confirmed in writing as confidential by the Disclosing Party to the Receiving Party within ten (10) days after disclosure. Unless Proprietary Information was previously known by the Receiving Party free of any obligation to keep it confidential, or has been or is subsequently made public by an act not attributable to the Receiving Party, or is explicitly agreed in writing not to be regarded as confidential, or is independently developed by the Receiving Party, the Parties hereby agree that in addition to the confidentiality requirements set forth in the Act and the Order, all Proprietary Information (i) shall be held in confidence by each Receiving Party; (ii) shall be disclosed on a confidential basis to only those persons who have a need for it in connection with the provision of services required to fulfill this Agreement and shall be used only for such purposes; and (iii) may be used for other purposes only upon such terms and conditions as may be mutually agreed to in advance of use in writing by the Parties. Notwithstanding the foregoing sentence, a Receiving Party shall be entitled to disclose or provide Proprietary Information as required by any governmental authority or applicable law only in accordance with Section 18(b) below.
- (b) If any Receiving Party is required by any governmental authority or by Applicable Law to disclose any Proprietary Information, then such Receiving Party shall provide the Disclosing Party with written notice of such requirement, to the extent permitted by law, as soon as possible and, where possible, prior to such disclosure. The Disclosing Party may then seek appropriate protective relief from all or part of such requirement, and the Receiving Party shall use all commercially reasonable efforts to cooperate with the Disclosing Party in attempting to obtain any protective relief which such Disclosing Party chooses to

obtain. Absent any restraining order or other relief prohibiting any such disclosure by the Receiving Party, then the Receiving Party shall be entitled to disclose such Proprietary Information and shall incur no liability hereunder as a result thereof.

- (c) In the event of the expiration or termination of this Agreement for any reason whatsoever, each Party shall return to the other Party or destroy all Proprietary Information and other documents, work papers and other material (including all copies thereof) obtained from the other Party in connection with this Agreement and shall use all reasonable efforts, including instructing its employees and others who have had access to such information, to keep confidential and not to use any such information, unless such information is now, or is hereafter disclosed, through no act, omission or fault of such Party, in any manner making it available to the general public.
- (d) The Receiving Party may make copies of Proprietary Information only as reasonably necessary to perform its obligations under this Agreement. All such copies shall bear the same copyright and proprietary rights notices as are contained on the original.
- (e) Except as otherwise expressly provided elsewhere in this Agreement, no license is hereby granted under any patent, trademark, or copyright, nor is any such license implied, solely by virtue of the disclosure of any Proprietary Information.

19. Number Portability

19.1 Interim Number Portability

- (a) Until Number Portability is implemented on an industry-wide basis pursuant to an order or regulation issued by the FCC or the Commission, the Parties agree to provide to each other Interim Number Portability (as defined in the Act, "INP") through remote call forwarding, route indexing, and full NXX code migration as set forth below or through any other technical solution which may, at the option of the Parties, be mutually agreed to by the Parties.
- (b) Upon implementation of Number Portability pursuant to an FCC or Commission regulation, both Parties agree to conform and provide such Number Portability in accordance with said

regulation. Once Number Portability is implemented, either Party may withdraw, at any time and at its sole discretion, its INP offerings, subject to reasonable advance written notice to the other Party.

- (c) In the event a Customer of one Party ("Party A") elects to become a Customer of the other Party ("Party B") and such Customer continues to reside within the same central office boundary and Rate Center, and elects to utilize the original telephone number(s) corresponding to the Exchange Service(s) it previously received from Party A in conjunction with the Exchange Service(s) it will now receive from Party B:
- (i) Party B shall, upon receipt from such Customer of the type of customer authorization required by the Commission or the FCC (together with an associated service order which, among other things, indicates that Party B has obtained the required customer authorization permitting assignment of the number to Party B), place an order with Party A to implement an arrangement whereby all calls to the original telephone number(s) will be forwarded to Party B over the appropriate Local/IntraLATA trunks for purposes of forwarding the call.
 - (ii) Party B shall become the customer of record for the original Party A telephone numbers subject to the INP arrangements provided that Party B continues to use the INP service for the use of the end user customer originally assigned such number, and in all respects shall be treated as the customer as to such number as if Party B has been assigned such number. Party A shall use its reasonable efforts to consolidate into as few billing statements as possible all collect, calling card, and third-number billed calls associated with those numbers, with sub-account detail by retained number. The parties shall work cooperatively to enable Party A to provide such billing statement to Party B in an agreed-upon format via either electronic file transfer, daily magnetic tape, or monthly magnetic tape.
 - (iii) Party A will update its Line Information Database ("LIDB") listings for retained numbers, as directed by Party B, and cancel calling cards associated with those forwarded

numbers.

- (iv) Within two (2) business days of receiving notification from the new Local Services carrier or the Customer terminating service with Party B, Party B shall notify Party A of the Customer's termination of service with Party B. Party A will cancel the INP arrangements for such Customer's telephone number(s). In the event Party A changes its telephone numbers, it may discontinue providing INP service as to such numbers.

- (d) Procedures for Providing INP Through Route Indexing. Either Party may deploy a Route Index arrangement which combines direct trunks provisioned between BELL ATLANTIC and COVAD's end offices with trunk side routing translations. Under this arrangement, inbound calls to a ported number will be pointed at a Route Index that sends the call to a dedicated trunk group, built as a direct final, for the sole purpose of facilitating completion for calls to a ported number. Each Party will coordinate with the other to provide this solution in a mutually agreeable and administratively manageable manner (e.g., NXX level) so as to minimize switch resource utilization for both Parties. COVAD shall pay to BELL ATLANTIC all costs and expenses incurred by BELL ATLANTIC in implementing such Route Indexing through tandems as requested by COVAD including, without limitation, all costs and expenses arising out of the development of necessary translations/reprogramming of existing trunk routing, the provision of additional dedicated trunks serving each affected tandem and the establishment of increased call processing and memory capacity to handle the increased volume of traffic, codes, translations and routing domains for all affected tandem or end office switches.

- (e) Procedures for Providing INP Through Full NXX Code Migration. Where either Party has activated an entire NXX for a single Customer, or activated a portion consisting in excess of fifty percent (50%) of an NXX Code for a single Customer with the remaining numbers in that NXX either reserved for future use or otherwise unused, if such Customer chooses to receive service from the other Party, the first Party shall cooperate with the second Party to have the entire NXX reassigned in the LERG (and associated industry databases, routing tables, etc.) to an end office operated by the second Party. Such transfer will be

accomplished with appropriate coordination between the Parties and subject to lead times specified in ATTIS Numbering Committee Guidelines 95-0407-008 C.O. Code (NXX) Assignment guidelines and NOF Reference Document, Part II, Section 2.3, NXX Code Opening for movements of NXXs from one switch to another.

- (f) The Parties shall pay to each other for ported telephone numbers the amounts determined in accordance with their respective tariffs (in the case of BELL ATLANTIC, P.S.C. No. 914 Tariff, or its successor), as in effect from time to time. Terminating IXC access charges shall be shared as required by the Commission between BELL ATLANTIC and COVAD pursuant to meet-point billing arrangements between the Parties using special estimated studies until such time as actual meet-point billing records are available.

19.2 Number Reassignment BELL ATLANTIC shall not be required to reassign to COVAD thousand number blocks (i.e., split NXX codes into blocks of a thousand numbers) in the Local Exchange Routing Guide ("LERG") except to the extent that BELL ATLANTIC agrees to such reassignment consistent with a change in the national guidelines for Central Office Code assignments.

20. Directory Listings and Directory Distributions

- (a) Except for COVAD customers of services resold by COVAD from BELL ATLANTIC pursuant to the PSC No. 915 Tariff as amended from time to time, which will be governed by that tariff, BELL ATLANTIC will include COVAD Customers' telephone numbers in all of its "White Pages" and "Yellow Pages" directory listings (including electronic directories) and directory assistance databases associated with the areas in which COVAD provides services to such Customers, and will distribute such directories to such Customers, in an identical and transparent manner in which it provides those functions for its own Customers' telephone numbers. In this Section 20, references to COVAD Customers' telephone numbers means telephone numbers falling within NXX codes directly assigned to COVAD and to numbers which are retained by COVAD on the customer's behalf pursuant to Interim Number Portability arrangements described in Section 19 of the General Terms and Conditions of this Agreement.

- (b) Intentionally Omitted
- (c) BELL ATLANTIC will include all COVAD NXX codes on appropriate existing calling charts in the BELL ATLANTIC Customer Guide section of the directory in the same manner as it provides this information for its own NXX Codes. BELL ATLANTIC shall assist COVAD in dealing with NIRC to facilitate NIRC's publication of COVAD Calling Charts or other COVAD information in the front portion of NIRC directories distributed in the NY Region. To the extent that COVAD provides Directory Listing information on its Service Order, BELL ATLANTIC will confirm that Directory Listing information on its Service Order Completion.
- (d) COVAD will provide BELL ATLANTIC with its directory listings and daily updates to those listings (including new, changes, and deleted listings) on a non-exclusive basis in a mutually agreed upon format at no charge.
- (e) BELL ATLANTIC will accord COVAD's directory listing information the same level of confidentiality which BELL ATLANTIC accords its own directory listing information.
- (f) BELL ATLANTIC shall provide COVAD at no charge with directory distribution for COVAD Customers. The Parties hereby acknowledge and agree that BELL ATLANTIC is not required, as per applicable tariffs, to provide more than one free white pages directory listing for each CENTREX system purchased for resale, regardless of the number of CENTREX lines purchased as part of such system.
- (g) BELL ATLANTIC will provide COVAD with a report of all COVAD customer listings 90 days prior to directory publication in such form and format as may be mutually agreed to by both parties. Both Parties shall use their best efforts to ensure the accurate listing of such information.
- (h) BELL ATLANTIC will work cooperatively with COVAD so that Yellow Page advertisements purchased by Customers who switch their service to COVAD (including Customers utilizing Interim Number Portability) are maintained without interruption. BELL ATLANTIC will allow COVAD customers to purchase new Yellow Pages advertisements without discrimination, under the identical rates, terms and conditions that apply to BELL ATLANTIC's customers.
- (i) BELL ATLANTIC will include, on one-eighth of a page, in the "Information Pages" or comparable section of its White Pages Directories for areas served by COVAD in the NY Region, listings provided by

COVAD for COVAD's installation, repair and customer service and other customer service-oriented information, including appropriate identifying logo. Such listings shall appear in the manner that such information appears for subscribers of BELL ATLANTIC and other LECs. BELL ATLANTIC shall not charge COVAD for inclusion of this information.

(j) Electronic Format Directory Assistance

Upon at least thirty days notice from COVAD, BELL ATLANTIC shall provide to COVAD in electronic format BELL ATLANTIC's master directory assistance listings for BELL ATLANTIC end user customers in the NY Region, exclusive of non-published numbers to the extent that BELL ATLANTIC is prohibited from selling or offering to sell such numbers under the Public Service Law. BELL ATLANTIC shall also provide COVAD with updates (containing adds, deletes and changes only) to these listings, at the same frequency that BELL ATLANTIC updates its own directory assistance database. The parties shall mutually agree to content, format and timing specifications for these directory assistance listings. Such directory assistance listings shall only be used by COVAD for the purpose of providing local directory assistance to COVAD local exchange service customers. COVAD shall pay BELL ATLANTIC a rate based on the cost of providing directory assistance listings and updates in an electronic format, including a reasonable profit.

21. Subscriber List Information

- (a) At COVAD's request, in accordance with Section 222(e) and (f) of the Act, for the purpose of publishing a directory in any format, BELL ATLANTIC shall provide to COVAD published Subscriber List Information on a timely basis via readily accessible tape or electronic formats on the same terms and conditions and at the same rates that BELL ATLANTIC provides its own Subscriber List Information to third party directory publishers. Changes to the Subscriber List Information shall be available on a timely basis through the same tape or electronic transfer means used to transmit the initial Subscriber List Information at the same rates and on the same terms and conditions that BELL ATLANTIC provides its own Subscriber List Information to third party directory publishers. Subscriber List Information provided by BELL ATLANTIC shall indicate whether the customer is a residence or business customer.

- (b) BELL ATLANTIC shall provide Subscriber List Information that includes COVAD Customers to third parties, as required by the Act, on the same terms and conditions and at the same rates that BELL ATLANTIC provides its own Subscriber List Information to third parties. COVAD shall receive its pro-rata share (calculated based on the proportionate share of COVAD Customers to the total number of customers included in the Subscriber List Information) of net proceeds realized by BELL ATLANTIC from third parties for such Subscriber List Information; provided, however, that BELL ATLANTIC shall not be required to include COVAD Customers in Subscriber List Information sales to third parties (other than COVAD) if BELL ATLANTIC promptly notifies COVAD of all requests by third party directory publishers and others for COVAD Subscriber List Information thus permitting COVAD to deal directly with said third parties.

22. Parity

BELL ATLANTIC's obligation to provide parity under this Agreement shall be in accordance with Applicable Laws.

23. Miscellaneous

23.1 Delegation or Assignment - Neither Party may assign or transfer (whether by operation of law or otherwise) this Agreement (or any rights or obligations hereunder) to a third party without the prior written consent of the other Party which consent shall not be unreasonably withheld or delayed; provided, however, each Party may assign this Agreement to a corporate Affiliate or an entity under its common control or an entity acquiring all or substantially all of its assets or equity by providing prior written notice to the other Party of such assignment or transfer. Any attempted assignment or transfer that is not permitted shall be void ab initio. All obligations and duties of any Party shall be binding on all successors in interest and assigns of such Party.

23.2 Nonexclusive Remedies - Except as otherwise expressly provided in this Agreement, each of the remedies provided under this Agreement is cumulative and is in addition to any remedies that may be available at law or in equity.

23.3 No Third Party Beneficiaries - Except as may be specifically set forth in this Agreement, this Agreement does not provide and shall not be construed to provide third parties with any remedy, claim, liability,

reimbursement, cause of action, or other privilege.

- 23.4 **Referenced Documents** - Unless otherwise specifically provided herein, whenever any provision of this Agreement refers to a technical reference, technical publication, COVAD Practice, BELL ATLANTIC Practice, any publication of telecommunications industry administrative or technical standards, or any other document specifically incorporated into this Agreement, it will be deemed to be a reference to the most recent version or edition (including any amendments, supplements, addenda, or successors) of such document that is in effect, and will include the most recent version or edition (including any amendments, supplements, addenda, or successors) of each document incorporated by reference in such a technical reference, technical publication, COVAD Practice, BELL ATLANTIC Practice, or publication of industry standards.
- 23.5 **Governing Law** - The validity of this Agreement, the construction and enforcement of its terms, and the interpretation of the rights and duties of the Parties shall be governed by the laws of the State of New York other than as to conflicts of laws, except insofar as federal law may control any aspect of this Agreement, in which case federal law shall govern such aspect. The forum for resolution of any dispute between the Parties shall be the State of New York.
- 23.6 **Publicity and Advertising** - Neither Party shall publish or use any advertising, sales promotions or other publicity materials that use the other Party's logo, trademarks or service marks without the prior written approval of the other Party. Neither BELL ATLANTIC nor COVAD may offer services to its end users or others under any of the brand names of the other Party or any of its parents, subsidiaries or affiliates, regardless of whether or not such brand names are registered trademarks or servicemarks, without the other Party's prior written authorization. Neither Party shall state or imply that there is any partnership or other joint business arrangement with the other Party, its parent, subsidiaries, or affiliates, for the provision of services to the other Party's end users or others. BELL ATLANTIC and COVAD may jointly develop a press release publicizing their relationship under this Agreement, subject to both (1) any prior non-disclosure agreement, and (2) mutually agreed upon language and media. Notwithstanding this section, COVAD is entitled to identify BELL ATLANTIC as the underlying carrier of the services provided hereunder.
- 23.7 **Amendments or Waivers** - Except as otherwise provided in this Agreement, no amendment or waiver of any provision of this Agreement,

and no consent to any default under this Agreement, shall be effective unless the same is in writing and signed by both Parties. In addition, no course of dealing or failure of a Party strictly to enforce any term, right or condition of this Agreement shall be construed as a waiver of such term, right or condition. By entering into this Agreement neither Party waives any right granted to it pursuant to the Act and/or the Order, except to the extent the Act or the Order permits such rights to be modified or waived and such modification or waiver is expressly set forth herein.

- 23.8 **Severability** - If any term, condition or provision of this Agreement is held to be invalid or unenforceable for any reason, such invalidity or unenforceability shall not invalidate the entire Agreement, unless such construction would be unreasonable. However, the Parties agree to meet and negotiate in good faith to arrive at a mutually acceptable modification of the invalid or unenforceable provision. If the Parties are unable to agree on such modification within 30 days after the Agreement provision(s) is held to be illegal, invalid or enforceable, such failure to agree shall be submitted for resolution pursuant to Section 16 of the General Terms and Conditions of this Agreement and resolved in accordance with the Dispute Resolution process.
- 23.9 **Entire Agreement** - This Agreement, which shall include the Attachments, Appendices, Exhibits and other documents referenced herein including all applicable tariffs referenced herein (as in effect from time to time), constitutes the entire Agreement between the Parties concerning the subject matter hereof and supersedes any prior agreements, representations, statements, negotiations, understandings, proposals or undertakings, oral or written, with respect to the subject matter expressly set forth herein. Neither Party shall be bound by any terms additional to or different from those in this Agreement that may appear subsequently in the other Party's form documents, purchase orders, quotations, acknowledgments, invoices or other communications.
- 23.10 **Survival of Obligations** - Any liabilities or obligations of a Party for acts or omissions prior to the cancellation or termination of this Agreement, any obligation of a Party under the provisions regarding indemnification, Proprietary Information, limitations on liability, and any other provisions of this Agreement which, by their terms, are contemplated to survive (or to be performed after) termination of this Agreement, shall survive expiration or termination hereof.
- 23.11 **Executed in Counterparts** - This Agreement may be executed in any number of counterparts, each of which shall be deemed on original, but

such counterparts shall together constitute one and the same instrument.

- 23.12 **Headings of No Force or Effect** - The headings of Articles and Sections of this Agreement are for convenience of reference only, and shall in no way define, modify or restrict the meaning or interpretation of the terms or provisions of this Agreement.
- 23.13 **Joint Work Product** - This Agreement is the joint work product of the Parties and their respective counsel and shall be fairly interpreted in accordance with its terms and, in the event of any ambiguities, no inferences shall be drawn against either Party.
- 23.14 **Nonexclusive Dealings** - This Agreement does not prevent either Party from providing or purchasing services to or from any other person nor, except as provided in Section 5 of the General Terms and Conditions and Exhibit A (Bona Fide Request Process) of Part II hereof, does it obligate either Party to provide or purchase any services not specifically provided herein.
- 23.15 **No License** - No license under patents, copyrights or any other intellectual property right (other than the limited license to use consistent with the terms, conditions and restrictions of this Agreement) is granted by either Party or shall be implied or arise by estoppel with respect to any transactions contemplated under this Agreement.
- 23.16 **Dialing Parity** - The Parties shall provide dialing parity to each other as required under Section 251(b)(3) of the Act, except as may be limited by Section 271(e)(2)(B) of the Act.
- 23.17 **Integrity of BELL ATLANTIC Network** - The Parties acknowledge that BELL ATLANTIC, at its election, may deploy fiber throughout its network and that such fiber deployment may inhibit or facilitate COVAD's ability to provide service using certain technologies. Notwithstanding any other provision of this Agreement, BELL ATLANTIC shall have the right to deploy, upgrade, migrate and maintain its network at its discretion.

IN WITNESS WHEREOF, the authorized officers of the parties have duly executed this Agreement as of this 16th day of December, 1997.

NEW YORK TELEPHONE COMPANY

COVAD COMMUNICATIONS CO.

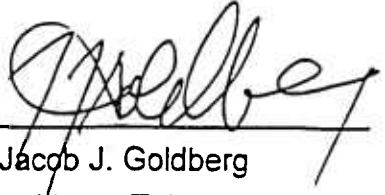
By: 
Name: Jacob J. Goldberg
Title: President - Telecom Industry Services

By: 
Name: Charles J. McMinn
Title: President and CEO

EXHIBIT A, APPENDIX 1

NON-RECURRING CHARGE INSTALLMENT PAYMENT OPTION FOR COLLOCATION AND CENTRAL OFFICE SWITCH DIALING PLANS

1. Subject to the terms and conditions specified below, [CLEC] may, at its option, elect to pay nonrecurring charges for collocation and central office switch dialing plans (if applicable) on an installment basis over an 18 month period.
2. [CLEC] will be eligible for this payment option only if [CLEC] and its affiliates (as affiliates are defined in the Act), if any, have gross revenue of less than \$2 billion per year arising from the provision of telecommunications services or facilities at the time the order is placed. BA may require [CLEC] to establish its eligibility under this section to BA's reasonable satisfaction.
3. The following non-recurring charges are subject to this installment payment option:
 - (a) For physical collocation: all elements associated with conditioning the space for collocation room construction (including but not limited to power plant upgrades, HVAC and asbestos removal), cage construction, overhead lighting and AC outlet, as well as cable installation.
 - (b) For virtual collocation: all elements associated with equipment installation and cable installation.
 - (c) All non-recurring charges associated with office dialing plans.
4. For physical collocation, the first payment will reflect 20% of the estimate rendered for construction of the room (common area), or pro rata amount if the room has already been built. Eighteen subsequent monthly payments will commence once the collocation site is complete (subject to tariffed interval) and will be based on the balance of room construction plus cage construction, overhead lighting, AC outlet and cable installation charges.
5. For virtual collocation, the first payment will reflect 20% of the total estimated cost for the entire virtual collocation arrangement. Eighteen subsequent monthly payments will commence once the collocation site is complete and service is rendered (subject to tariffed interval) and will be based on the balance of charges due.
6. For office dialing plans, the first payment will reflect 20% of the estimate to develop and implement the plan. Eighteen subsequent monthly payments will commence once the plan is in place (usually between 60 and 120 days).

7. The amount of each subsequent monthly installment payment shall equal the total remaining non-recurring charge that would otherwise apply, divided by 18 payments, and increased by an annual factor of 12.2%. This factor is intended to reflect BA's cost of money and anticipated bad debt. The result is that each of the 18 payments shall consist of 6.05% of the original total amount of non-recurring charge before deduction of the initial 20% payment. An additional payment of \$196.94 per month will apply for the duration of the installment period, based on the costs to BA of administering the installment option.
8. The charges under this installment option are designed to be revenue neutral to BA compared to the payment of a one-time charge, and are subject to periodic prospective adjustments as often as quarterly to reflect actual bad debt experience, churn rates, administrative costs, or changes in the cost of money.
9. If the service is removed before all installment payments have been made, the remaining unpaid amount of the non-recurring charge shall be due and payable.
10. This installment payment option is offered by BA in fulfillment of a condition imposed by the FCC in approving the merger of Bell Atlantic Corporation and NYNEX Corporation. The availability, terms and conditions of this payment option are subject to change based on any change in, or definitive reinterpretation of, the underlying merger condition.
11. Unless expressly renewed by BA, this installment payment option will not be available for orders with due dates after August 14, 2001, according to standard intervals.
12. Service provided under this installment payment option is subject to all other terms and conditions of this Agreement or applicable tariffs, including those relating to deposits, billing, form of payment, late payment charges, and dispute resolution, if any. [CLEC] hereby grants to BA a continuing security interest in and to all of [CLEC]'s personal property including [CLEC]'s now-owned and hereafter acquired accounts, goods, general intangibles, equipment, inventory, and contract rights and in the proceeds and products thereof. The security interest granted hereby is to secure payment and performance of the obligations of [CLEC] hereunder. [CLEC] hereby agrees to execute all documents, including financing statements, required by BA to evidence, perfect and enforce the security interest granted hereunder. In the event of a default, BA shall have all rights and remedies available to it under the Uniform Commercial Code in addition to any rights and remedies available under law or equity.

EXHIBIT A, APPENDIX 2

OPTIONAL RECURRING PAYMENT PLAN FOR RESOLD SERVICES AND UNBUNDLED NETWORK ELEMENTS

1. Subject to the following terms and conditions, [CLEC] may, at its option, elect to pay nonrecurring charges ("NRCs") for resold services and unbundled network elements over 18 months under an Optional Recurring Payment Plan ("Plan"), as described below.
2. The Plan shall apply to non-recurring charges incurred for resold services and for unbundled network elements purchased by [CLEC] for the provision of basic residence and business dial tone line exchange or exchange access services (including vertical features) to retail customers.
3. Once [CLEC] elects the Plan, [CLEC] is responsible for invoking the recurring payment option on each Local Service Request (LSR) or Access Service Request (ASR) submitted. All applicable NRCs on the same LSR/ASR will be billed on a recurring basis in accordance with the Plan.
4. The amount of each monthly payment shall equal the total remaining non-recurring charge that would otherwise apply, divided by 18 payments, and increased by a factor of 12.2%. This factor is intended to reflect BA's cost of money and anticipated bad debt. The result is that each of the 18 payments shall consist of 6.05% of the original total amount of non-recurring charge. An additional payment of \$196.94 per month will apply for the duration of the 18-month period, based on the costs to BA of administering the Plan.
5. The charges under this payment option are designed to be revenue neutral to BA compared to the payment of NRCs on a one-time basis, and are subject to periodic prospective adjustments as often as quarterly to reflect actual bad debt experience, churn rates, administrative costs, or changes in the cost of money.
6. This payment option is offered by BA in fulfillment of a condition imposed by the FCC in approving the merger of Bell Atlantic Corporation and NYNEX Corporation. The availability, terms and conditions of this payment option are subject to change based on any change in, or definitive reinterpretation of, the underlying merger condition.
7. Unless expressly renewed by BA, this payment option will not be available for orders with due dates after August 14, 2001, according to standard intervals.
8. Service provided and payments made under the Plan are subject to all other terms and conditions of this Agreement or applicable tariffs, including those relating to deposits, billing, form of payment, late payment charges, and dispute resolution, if any. [CLEC] hereby grants to BA a continuing security interest in and to all of [CLEC]'s personal property including [CLEC]'s now-owned and hereafter acquired accounts, goods,

general intangibles, equipment, inventory, and contract rights and in the proceeds and products thereof. The security interest granted hereby is to secure payment and performance of the obligations of [CLEC] hereunder. [CLEC] hereby agrees to execute all documents, including financing statements, required by BA to evidence, perfect and enforce the security interest granted hereunder. In the event of a default, BA shall have all rights and remedies available to it under the Uniform Commercial Code in addition to any rights and remedies available under law or equity.

PART I: INTENTIONALLY OMITTED

PART II: UNBUNDLED NETWORK ELEMENTS

1. Introduction

1.1 BELL ATLANTIC agrees to offer to COVAD unbundled Network Elements and to allow combination of the BELL ATLANTIC-provided unbundled Network Elements in accordance with its obligations under Section 251(c)(3) of the Act and the Order. The specific terms and conditions that apply to the provision of the unbundled Network Elements are set forth in this Part II. Unless otherwise noted below, the prices for each unbundled Network Element shall be governed by Part IV of this Agreement. Prices for any unbundled Network Element not listed in this Agreement shall be determined through the Bona Fide Request Process set forth in Exhibit A of this Part II (the "BFR Process"), except as otherwise expressly provided in Section 2.9 of this Part II. Any non-recurring/miscellaneous charges which may be applicable to the purchase of unbundled Network Elements shall be governed by Part IV of this Agreement.

1.2 The unbundled Network Elements and rates specified in this Agreement shall be made available by BELL ATLANTIC to COVAD pursuant to and to the extent required by Applicable Law. Unless otherwise provided in this Agreement, the unbundled Network Elements specified in this Agreement shall be made available by BELL ATLANTIC to COVAD for ordering and provisioning on the Effective Date.

If pursuant to the Order, COVAD requests interconnection to unbundled Network Elements that are different from those required by the Act or Order or are not specified in this Agreement, COVAD agrees that any such request shall be subject to the BFR Process, except as otherwise expressly provided in Section 2.9 of this Part II.

1.3 BELL ATLANTIC and COVAD agree to work cooperatively to implement technical guidelines to prevent degradation or other impairments to the quality or reliability of either Party's network. If BELL ATLANTIC reasonably determines that any particular Local Loop or other unbundled Network Element used by COVAD is interfering with or impairing BELL ATLANTIC's provision of services, BELL ATLANTIC shall have the right to interrupt its provision of that particular loop or other unbundled Network Element, subject, however, to the following:

a) BELL ATLANTIC shall have given COVAD at least ten (10) days'

prior written notice of the interference or impairment and the need to correct the condition within said time period.

- b) BELL ATLANTIC shall have concurrently provided a copy of the notice provided to COVAD under subsection (a) above to the appropriate federal and/or state regulatory bodies.
- c) Notice in accord with subsection (a) above shall not be required in emergencies and BELL ATLANTIC may immediately discontinue its provision of the particular loop or other unbundled Network Element if such discontinuance is reasonably necessary to avoid interference with or impairment to BELL ATLANTIC's network or services. In such case, however, BELL ATLANTIC shall use all reasonable means to notify COVAD.
- d) Upon correction of the interference or impairment, which may include relocation at appropriate rates and charges, BELL ATLANTIC will promptly renew its provision of the loop or other unbundled Network Element. During such period of discontinuance, there will be no compensation or credit allowance by BELL ATLANTIC to COVAD for interruptions.

Except as otherwise provided, the provisions of this section shall not apply to ADSL and HDSL compatible loops provided to COVAD by BELL ATLANTIC pursuant to Section 2.9.1(g) of this Agreement.

2. Unbundled Network Elements

- 2.1 BELL ATLANTIC will offer Network Elements to COVAD on an unbundled basis on terms and subject to conditions that are just, reasonable, and non-discriminatory in accordance with the terms and conditions of this Agreement and the requirements of Section 251 and Section 252 of the Act and the Order, as applicable.
- 2.2 To the extent required by Applicable Law, BELL ATLANTIC will permit COVAD to interconnect COVAD's facilities or facilities provided to COVAD by third parties with each of the unbundled Network Elements provided by BELL ATLANTIC at any point requested by COVAD that is technically feasible. Any request by COVAD to interconnect at a point not previously established in accordance with the terms of this Agreement (i.e., other than as set forth in the descriptions of unbundled Network Elements under

Section 2.9 of this Part II) shall be subject to the BFR Process.

- 2.3 At the time COVAD provides BELL ATLANTIC with an order for particular unbundled Network Elements provided under this Agreement, COVAD may request any technically feasible network interface, including without limitation, to the extent deployed and available in the BELL ATLANTIC network, and where requested by COVAD: (1) DSO, DS-1, DS-3, STS-1, and OC-n (where n equals those industry standard numbers between 1 and 48) interfaces, and (2) any other interface described in the applicable Bellcore and other industry standard technical references. Any such requested network interface shall be subject to the approval of BELL ATLANTIC, which approval shall not be unreasonably withheld or delayed. If COVAD's request is denied, BELL ATLANTIC shall provide COVAD with written notice of said denial specifically describing why it is technically infeasible for BELL ATLANTIC to comply with COVAD's request.
- 2.4 COVAD may use one or more unbundled Network Elements to provide to itself, its affiliates and to COVAD Customers any feature, function, or service option that such unbundled Network Element is presently capable or becomes capable of providing in the BELL ATLANTIC network, or any feature, function, or service option that is described in the applicable Bellcore and other industry standard technical references identified herein and which the BELL ATLANTIC network has the capability of providing on the Effective Date of this Agreement and thereafter as such capability may be expanded, or as may otherwise be agreed to by the Parties.
- 2.5 BELL ATLANTIC shall permit COVAD to combine any unbundled Network Element or unbundled Network Elements provided by BELL ATLANTIC with another unbundled Network Element or other unbundled Network Elements obtained from BELL ATLANTIC or with compatible network components provided by COVAD or provided by third parties to COVAD to provide Telecommunications Services to COVAD, its affiliates and to COVAD Customers. Notwithstanding the foregoing, without additional components furnished by COVAD to itself or through third parties, COVAD shall only be permitted to combine unbundled Network Elements made available by BELL ATLANTIC with other contiguous BELL ATLANTIC unbundled Network Elements.
- 2.6 For each appropriate unbundled Network Element, BELL ATLANTIC shall provide a demarcation point and, if necessary and appropriate, access to such demarcation point.

2.7 Intentionally omitted

2.8 Intentionally omitted

2.9 Subsections 2.9.1 through 2.9.8 of this Section 2:9 list the unbundled Network Elements that COVAD and BELL ATLANTIC have identified as of the Effective Date of this Agreement and which are described in the Order (the "Agreed Elements"). COVAD and BELL ATLANTIC agree that the unbundled Network Elements identified in this Part II are not exclusive and that pursuant to the BFR Process COVAD may identify and request that BELL ATLANTIC furnish additional or revised unbundled Network Elements to the extent required under the Act. Additionally, if BELL ATLANTIC provides any unbundled Network Element or interconnection arrangement that is not identified in this Agreement to a requesting Telecommunications Carrier, including a BELL ATLANTIC affiliate, BELL ATLANTIC will make available the same unbundled Network Element or interconnection arrangement to COVAD without COVAD being required to use the Bona Fide Request Process, to the extent required by Section 252 (i) of the Act. The descriptions of unbundled Network Elements that are Agreed Elements in this Section 2.9 do not address, directly or by implication, the charge or charges that apply. As of the Effective Date of this Agreement, charges for unbundled Network Elements shall be as specified in Part IV hereof.

2.9.1. The "Local Loop" is a transmission facility between a distribution frame, or its equivalent, in the BELL ATLANTIC central office, and the demarcation point at the Customer premises. All Local Loops will be provided with a NID or other protective device at the rate specified in Part IV. All Local Loops will be provisioned by BELL ATLANTIC and used by COVAD in conformance with Bellcore standard GR-1089.

The Local Loops, as described below, may be used to provide modes of transmission that include: 2-wire and 4-wire analog voice grade loops and 2-wire and 4-wire transmission of ISDN, ADSL, HDSL and DS1 level digital signals, as follows:

- (a) "2-Wire Analog Voice Grade Loop" or "Analog 2W," will support analog transmission of 300-3000 Hz, repeat loop start, loop reverse battery, or ground start seizure and disconnect in one direction (toward the End Office Switch), and repeat ringing in the other direction (toward the Customer) and terminates at both

the central office MDF (or equivalent) and the Customer premises. Analog 2W includes Loops sufficient for the provision of PBX trunks, pay telephone lines and electronic key system lines. Current BELL ATLANTIC Loop design guidelines follow ANSI T1.601 and Bellcore TR-NWT-000393 recommendations, with a process of loop classification specified in Bellcore's SR-2275. If COVAD orders one or more Local Loops serviced by Integrated Digital Loop Carrier or Remote Switching technology deployed as a Local Loop Concentrator, without the associated switch port, then BELL ATLANTIC shall, where available, provision the requested Local Loop(s) using its choice of spare existing physical Local Loop(s) that do not require multiplexing, at no charge to COVAD. If, however, such other facilities are not available, BELL ATLANTIC shall offer COVAD other options provided that COVAD shall agree to pay the additional costs approved by the Commission incurred by BELL ATLANTIC in making such other option(s) available to COVAD. If the option BELL ATLANTIC offers is shared by other Customers in addition to COVAD, the Parties shall develop an equitable basis for allocating the additional cost among all users of the facility. BELL ATLANTIC and COVAD shall work cooperatively to develop the details and costs of such options as part of the Operations Plan.

- (b) "4-Wire Analog Voice Grade Loop" or "Analog 4W," which supports transmission of voice grade signals using separate transmit and receive paths and terminates in a 4-wire electrical interface at both ends.
- (c) "2-Wire ISDN-Compatible Digital Loop" or "BRI-ISDN," which supports digital transmission of two 64 kbps bearer channels and one 16 kbps data channel (2B + D). BRI-ISDN is a 2B + D Basic Rate Interface-Integrated Services Digital Network (BRI-ISDN) Loop which will meet national ISDN standards and conform to Technical Reference ANSI T1.601 & T1E1.490-004R3. Subject to the provisions of Section 1.3, COVAD may, at its discretion and at its own risk, use a BRI-ISDN Local Loop for the provision of modes of transmission other than BRI-ISDN Local Loop as described herein. BELL ATLANTIC makes no representations or promises with respect to the suitability of a BRI-ISDN Local Loop for the modes of transmission used by COVAD. The 2-wire Conditioned Link (Local Loop) rate and relevant charges, specified in Part IV of this Agreement, shall

apply to these Loops.

- (d) "4-Wire 64 Kbps Digital Loop" or "4-Wire 64 Digital," is a transmission path which supports transmission of digital signals of up to a maximum binary information rate of 64 kbps and terminates in a 4-Wire electrical interface at both the Customer premises and on the MDF in BELL ATLANTIC's Central Office. 4-Wire 64 kbps Digital are available only where existing copper facilities can meet the requirements specified in ANSI T1.410.1992. Subject to the provisions of Section 1.3, COVAD may, at its discretion and at its own risk, use a 4-Wire 64 Digital Local Loop for the provision of modes of transmission other than ISDN subject to the technical limitations of the 4-Wire 64 Digital Local Loop as described herein. BELL ATLANTIC makes no representations or promises with respect to the suitability of a 4-Wire 64 Digital Loop for the modes of transmission used by COVAD. The 4-wire Conditioned Link (Local Loop) rate and relevant charges, specified in Part IV of this Agreement, shall apply to these Loops.
- (e) "4-Wire 1.544 Mbps Digital Loop" or "1.544 Mbps Digital," is a transmission path which supports transmission of digital signals of up to a maximum binary information rate of 1.544 mbps and terminates in a 4-Wire electrical interface at the Customer premises and on the DSX frame in BELL ATLANTIC's Central Office. 1.544 Mbps Digital will be provided in accordance with the relevant and applicable specifications, interfaces and parameters described in Technical Reference ANSI T1.102.
- (f) "Digital Signal Level 3 Loop" or "DS3 Loop" is a transmission path which supports transmission of digital signals up to a maximum binary information rate of 44.736 Mbps (the third-level in the time division multiplex hierarchy) and terminates in an electrical interface at the customer premises and on a DSX frame in a BELL ATLANTIC central office. BELL ATLANTIC will provide DS3 Loops pursuant to P.S.C. No. 916 Tariff.
- (g) ADSL and HDSL Compatible Local Loops
At COVAD's request, BELL ATLANTIC will provide ADSL and HDSL Compatible Local Loops, described in paragraph (4) of this subsection, after successful completion of a Technical Trial, if necessary, and an Operational Trial for Two-Wire ADSL, Two-

Wire HDSL and Four-Wire HDSL Compatible Local Loop types. A Technical Trial is required prior to an Operational Trial; however, the Technical and/or operational Trial may or may not involve COVAD. Upon COVAD's request, BELL ATLANTIC will advise COVAD as to the status of any ongoing technical and/or operational trials conducted by BELL ATLANTIC and the need for a technical and/or operational trial with COVAD. The ADSL and HDSL Compatible Local Loops must terminate on a NID at a customer premises and in COVAD's Collocation space.

If BELL ATLANTIC makes generally available any 2-wire ADSL, 2-wire HDSL, or 4-wire HDSL service in any of its service territories in the state of New York, the Technical Trial required by 2.9.1(g)(1) will not be required. BELL ATLANTIC shall exercise its best efforts to utilize all technical data available to it to satisfy its requirement to conduct a Technical Trial. BELL ATLANTIC shall share with COVAD, upon COVAD's written request, the technical trial results related to potential interference issues of any ADSL or HDSL technical trial that BELL ATLANTIC has undertaken with another Telecommunications Carrier in its service territory. The results of such other Technical Trials may be used to satisfy the Technical Trial required under Section 2.9.1(g)(1).

If a Technical Trial is not required, COVAD may request an Operational Trial in accordance with Section 2.9.1(g)(1), provided that COVAD agrees to (i) conform to BELL ATLANTIC's published technical standards, guidelines or procedures that result from other technical trials or that are used in the general deployment of such service(s), and (ii) uses technology that is substantially similar to that underlying the technical data subject to the other technical trials, relied on by BELL ATLANTIC, or used in the general deployment of such service(s).

Notwithstanding the requirements of this Section 2.9.1, BELL ATLANTIC will offer COVAD nondiscriminatory access to 2-wire and 4-wire ADSL-Compatible and HDSL-Compatible Loops that BELL ATLANTIC offers to any Telecommunications Carrier in the state of New York to the extent required by applicable law.

(1) Trial Milestones

COVAD shall notify BELL ATLANTIC of its request for a Technical and/or Operational Trial in writing and share

any technical information pertinent to such trial concerning potential interference issues. COVAD will provide BELL ATLANTIC with a list of proposed locations for said trial(s). BELL ATLANTIC will indicate a suitable location from such list for said trial within 15 business days of receipt of COVAD's list. In the event COVAD does not have a suitable Collocation space at the designated trial location, it shall submit a Collocation Application within 30 business days of the trial request. The Parties shall then meet to agree upon a Trial Plan for the requested trial(s). The Trial Plan shall include, but is not limited to, the minimum and maximum volumes for each Local Loop type (which shall be in the range of 10 to 20 loops), the trial location, the technical and/or operational trial parameters and expected results for the specified technical and/or operational trial. The Trial Plan shall be a joint work effort completed no later than the completion of Collocation space to be used in the trial, if ordered, or 120 days from the trial request, whichever is later, or as otherwise mutually agreed.

COVAD shall provide BELL ATLANTIC with fourteen (14) days written prior notice of its Equipment Ready Date (ERD). Such notice shall indicate the date upon which COVAD can and will accept termination and turn-up of the trial Local Loop(s). The Technical Trial shall commence no later than 10 business days from the ERD and shall be of a duration of not more than 60 days. The Operational Trial shall commence the later of 30 days from the ERD or July 1, 1998 and shall be of a duration of not more than 60 days.

Upon successful completion as defined in the Trial Plan of the Technical Trial, if necessary, and Operational Trial, which includes, but is not limited to, the resolution of any network interference or other network impairments issues, the Parties shall agree upon an implementation schedule for deployment of the unbundled local loop type(s) subject to such trial(s). Within 60 days of successful completion of the Operational Trial as defined in the Trial Plan, BELL ATLANTIC will publish relevant documentation. At that time, COVAD may order and use the type of Local Loop which had been subject to a trial in conformance with the BELL ATLANTIC published

references and guidelines for such Local Loop type.

(2) Rates

The 2 Wire Conditioned LINK (Local Loop) rate and other charges, specified in Part IV of this Agreement, shall apply during the Operations Trial and thereafter for Two-Wire ADSL and Two-Wire HDSL Compatible Local Loops. The 4 Wire Conditioned LINK (Local Loop) rate and other charges, specified in Part IV of this Agreement, shall apply during the Operations Trial and thereafter for Four-Wire HDSL Compatible Local Loops. Such Conditioned LINK rates shall apply to the provision of ADSL and HDSL Compatible Local Loops until such time as Bell Atlantic establishes ADSL and HDSL Compatible Local Loops rates which shall apply thereafter.

(3) Interference

During and until successful completion of the Technical and Operational Trial(s), BELL ATLANTIC, at its sole discretion, has the right to terminate, modify or reconfigure COVAD's unbundled ADSL or HDSL Compatible Local Loops deployed as part of the Trial(s), which BELL ATLANTIC determines to cause interference or other impairments to the services or facilities provisioned by BELL ATLANTIC to itself or others as set forth in Section 1.3 of this Part II.

After the successful completion of the Operational Trial as defined in the Trial Plan and subject to the BELL ATLANTIC published technical references and guidelines:

- i) COVAD shall be able to order and BELL ATLANTIC shall provision ADSL and HDSL Compatible Local Loops.
- ii) In its use of ADSL and HDSL Compatible Local Loops, COVAD shall conform to the BELL ATLANTIC references and guidelines such that its provision of services to its customers does not degrade or otherwise adversely affect the quality or reliability of service to BELL ATLANTIC's customers provided that BELL ATLANTIC is in compliance with the provisions

of this Section.

- iii) BELL ATLANTIC shall conform to its guidelines and shall not introduce services on its network that would degrade or otherwise adversely affect the quality or reliability of service to COVAD's customers provided that COVAD is in compliance with the provisions of this Section.

If COVAD determines that BELL ATLANTIC is using a loop provisioned with ADSL or HDSL technology in a manner that will or may interfere with or impair COVAD's provision of its services, COVAD shall notify BELL ATLANTIC in a reasonable manner and time frame. If BELL ATLANTIC determines that COVAD is using an ADSL or HDSL Compatible Local Loop in a manner that will or may interfere with or impair BELL ATLANTIC's provision of its services, BELL ATLANTIC shall notify COVAD in a reasonable manner and time frame. The Parties agree to work cooperatively to resolve interference or other impairment issues. In the event a cooperative resolution cannot be reached, the procedures for Service-Affecting Disputes in Part 16 of the General Terms of this Agreement shall apply.

(4) ADSL and HDSL Compatible Local Loop Descriptions

Upon successful conclusion of the Technical Trial, BELL ATLANTIC may modify or change the following descriptions to conform with the results of the Technical Trial.

- i) "2-Wire ADSL-Compatible Loop" or "ADSL 2W," is a transmission path which facilitates the transmission of up to 6 Mbps digital signal downstream (toward the Customer) and up to 640 kbps digital signal upstream (away from the Customer) while carrying an analog voice signal. An ADSL 2W is provided over a 2-Wire, non-loaded twisted copper pair provisioned using revised resistance design guidelines and meeting ANSI Standard T1.413-1995-007R2. An ADSL 2W terminates in a 2-wire electrical interface at the Customer premises and at the BELL ATLANTIC Central Office frame. ADSL-compatible Local Loops are only available where existing copper facilities can meet the ANSI T1.413-1995-007R2

specifications.

- ii) "2-Wire HDSL-Compatible Loop" or "HDSL 2W," is a transmission path which facilitates the transmission of a 768 kbps digital signal over a 2-Wire, non-loaded twisted copper pair meeting the specifications in ANSI T1E1 Committee Technical Report Number 28/T1E1.4/92-002R3. HDSL-compatible Local Loops are available only where existing copper facilities can meet the T1E1 Technical Report Number 28 specifications.
 - iii) "4-Wire HDSL-Compatible Loop" or "HDSL 4W," is a transmission path which facilitates the transmission of a 1.544 Mbps digital signal over 4-Wire, non-loaded twisted copper pairs meeting the specifications in ANSI T1E1 Committee Technical Report Number 28. HDSL-compatible Loops are available only where existing copper facilities can meet the T1E1 Technical Report Number 28 specifications.
- (5) If COVAD orders one or more ADSL-Compatible or HDSL-Compatible Local Loop(s) serviced by Integrated Digital Loop Carrier or Remote Switching technology deployed as a Local Loop Concentrator, without the associated switch port, then BELL ATLANTIC shall, where available, provision the requested Local Loop(s) using its choice of spare existing physical Local Loop(s) that do not require multiplexing, at no charge to COVAD. If however, such other facilities are not available, BELL ATLANTIC shall offer COVAD other option(s), which shall, where feasible, include the placement of a suitable digital line card at the remote terminal, provided that COVAD shall agree to pay the additional costs incurred by BELL ATLANTIC in making such other option(s) available to COVAD. If the option BELL ATLANTIC offers is shared by other Customers in addition to COVAD, the Parties shall develop an equitable basis for allocating the additional cost among all users of the facility. BELL ATLANTIC and COVAD shall work cooperatively to develop the details and costs of such option(s) as part of the Operations Plan.

- (6) At such time as BELL ATLANTIC offers ADSL and HDSL

Compatible Local Loops, under Section 2.9.1 (g), and to the extent BELL ATLANTIC develops a pre-order loop qualification database for such Local Loops, it shall provide COVAD access to such database, at rates and charges to be determined.

2.9.2 The "Network Interface Device (NID)" is a single-line termination device or that portion of a multiple-line termination device required to terminate a single line or circuit. The NID provides: a network termination for the Local Loop, voltage overload protection to ground, termination for optional test apparatus, proper signal termination, and a point of termination and connection for a Customer's "inside" wiring. A modern NID features two chambers or divisions which separate the service provider's network from the end-user's inside wiring. Each chamber or division contains the appropriate connection points or posts to which the service provider, and end-user each make their connections. Upon COVAD's written request, or electronically transmitted request delivered through an established interface, a direct connection between COVAD's NID and BELL ATLANTIC's NID will be established; provided that only BELL ATLANTIC's own technicians may perform the necessary work to effect such direct connection. Alternatively, upon COVAD's written request, or electronically transmitted request delivered through an established interface, a direct connection between COVAD's Local Loop and BELL ATLANTIC's NID may be established; provided that with respect to such direct connection there is adequate spare capacity on BELL ATLANTIC's NID, and, provided further, that only BELL ATLANTIC's own technicians may perform the necessary work to effect such direct connection. BELL ATLANTIC shall be entitled to payment from COVAD for making the connection, as provided in Part IV of this Agreement.

2.9.3 "Local Switching" is the Network Element that provides the functionality required to connect the appropriate originating lines or trunks wired to the Main Distributing Frame (MDF) or Digital Cross Connect (DSX) panel to a desired line or trunk appearance on the Local Switch. COVAD may request shared or dedicated routing. COVAD shall define the routing plan (*i.e.*, customized routing) that will be used by its Customers for each BELL ATLANTIC switch in which unbundled Local Switching will be provided pursuant to the Network Design Request process at rates, charges for Customized Routing shall be as provided in Part IV of this Agreement. Customized Routing will be provided where facilities and equipment exist pursuant to the rates and process for Network Design Requests specified in PSC No.

916 Tariff. BELL ATLANTIC will implement, where it is technically feasible to do so and where facilities exist that dialing plan and any associated dedicated trunking needed to support the introduction of customized routing on that Local Switching Network Element. The Local Switching functionality shall include all of the features, functions and capabilities that BELL ATLANTIC has purchased or has the right to use, including but not limited to: line signaling, signaling capabilities of the switch, digit reception, dialed number translations, call screening (the switch-based feature which permits the switch to differentiate line treatment or routing based on specific classes of service), routing, recording, call supervision, dial tone, switching, network address (when available in the particular switch) to directory number, announcements, calling features and capabilities (including call processing), Centrex features and functionality, Automatic Call Distributor (ACD), Carrier pre-subscription (e.g., long distance carrier, intraLATA toll as deployed), testing and other operational features inherent to the switch and switch software; provided, however, that in cases where COVAD wishes to activate a feature or function in the BELL ATLANTIC network or in a specific switch with respect to which capacity problems may affect BELL ATLANTIC's ability to utilize services or features for its own use or offer services to other Telecommunications Carriers, the Parties agree to work cooperatively to seek a solution to such capacity problem to the extent technically feasible. In the event that a capacity problem cannot be resolved to the mutual satisfaction of both Parties, switch capacity will be made available to BELL ATLANTIC, COVAD and other Telecommunications Carriers on a first come, first serve basis (without reservation of capacity for BELL ATLANTIC, COVAD or other Telecommunications Carriers), and new service requests will be approved or denied on a first come, first serve basis. When BELL ATLANTIC and other Telecommunications Carriers use the last remaining capacity in a switch on a first come, first serve basis, BELL ATLANTIC shall have no obligation to augment or add switches to meet COVAD's requirements except as may be required pursuant to the Bona Fide Request Process. If BELL ATLANTIC does augment switch capacity or add switches to satisfy its needs or the needs of other Telecommunications Carriers, any such new capacity or additional switches shall also be made available to COVAD on a first come, first serve basis with BELL ATLANTIC and the other Telecommunications Carriers. Where BELL ATLANTIC provides COVAD with Local Switching features which BELL ATLANTIC has a right to use but has not deployed for its own Customers, COVAD shall pay to BELL ATLANTIC all costs and expenses incurred by BELL ATLANTIC in providing such features. The calculation of such costs and expenses shall be on an ICB basis, taking into account the

requested features and the affected switch, and shall not include any amount to reimburse BELL ATLANTIC for RTU fees in those instances where such RTU fees were previously paid by BELL ATLANTIC for the specific requested features prior to COVAD's request. Such costs and expenses shall be submitted to the Commission for review. Local Switching also provides, to the same extent such switch currently provides to BELL ATLANTIC such access on the Effective Date hereof and thereafter as such access may be expanded, access to: transport, signaling (ISDN) User Part (ISUP) and Transaction Capabilities Application Part (TCAP), and platforms such as adjuncts, Public Safety Systems (911), operator services, directory services, and, when and where available, Local Switching ports adhering to Bellcore TR-NWT-08 and TR-NWT-303 specifications, and Advanced Intelligent Network (AIN) described in Section 2.11 of this Part II. Remote Switching Module (RSM) functionality as it relates to termination of Customer lines or trunks is included in the Local Switching Network Element. RSM functionality, however, does not include support of COVAD's RSM on BELL ATLANTIC's host switch. The switching capabilities used will be based on the line side features they support. Local Switching will also be capable of routing local, intraLATA, interLATA, and, when and where available, calls to an international Customer's preferred carrier.

2.9.3.1 Local Switching also includes Circuit Switched Data (CSD) and ISDN Packet Switching, to the extent such CSD and ISDN Packet Switching are available to BELL ATLANTIC on the Effective Date hereof and thereafter as such availability may be expanded, which provide with respect to CSD service the circuit switching functionality that is required to switch and transport ISDN Circuit Switched Data between interfaces conforming to ISDN American National Standards for Telecommunications. For Local Switching, the purposes of ISDN Circuit Switched Data are to provide an ISDN-capable Local Exchange Termination, to route CSD calls to the proper termination (line, trunk or other switch), to provide efficient concentration of traffic, to provide necessary connectivity within the network, and to provide the switching features and capabilities to support ISDN. It is understood by both Parties that the Customer Premises Equipment at both ends of the call will be expected to conform to the appropriate American National Standard for ISDN Network Terminations applicable for CSD.

2.9.4 "Tandem Switching." The Tandem Switching Network Element

provides the switching function needed to establish a temporary transmission path between two other switching offices. It includes the facilities connecting the trunk distribution frames to the tandem switch, and all the functions of the tandem switch itself, including those facilities that establish a temporary transmission path between two other switches. It also includes functions that are centralized in the tandem, such as any call recording which is or becomes available in the tandem switch, and, in certain cases, routing of calls to tandem signaling conversion functions (e.g., MF to SS7) used in the BELL ATLANTIC network. Tandem switch call recording functions and capabilities are different from end office switch call recording functions and capabilities. BELL ATLANTIC will implement, where it is technically feasible to do so and where facilities exist that dialing plan and any associated dedicated trunking needed to support the introduction of customized routing on that Tandem Switching Network Element.

2.9.5 "Interoffice Transmission Facilities" is a Network Element which is provided either as Dedicated Transport or is in some cases BELL ATLANTIC Shared Transport. Bell Atlantic shall provide IOF pursuant to the PSC No. 916 Tariff and this subsection 2.9.5.

2.9.5.1 "BELL ATLANTIC Shared Transport" is a transmission facility which BELL ATLANTIC shares with at least one Customer or carrier between BELL ATLANTIC switching elements. This facility is paid for based upon usage plus any applicable non-recurring charges, and is provided in accordance with the terms and conditions specified in PSC No. 916 Tariff and this subsection.

2.9.5.2 "Dedicated Transport" is an interoffice transmission path between designated locations to which a single carrier is granted exclusive use. Such locations may include BELL ATLANTIC central offices or other equipment locations, COVAD network components, other carrier network components, or Customer premises. Dedicated Transport includes the Digital Cross Connect System (DCS) functionality as an option to the extent available on the Effective Date of this Agreement and thereafter as such functionality may become available. This facility is paid for based upon fixed monthly charges plus any applicable non-recurring charges, and is provided in accordance with the terms and conditions specified in PSC No. 916 Tariff and

this subsection.

2.9.6 "Operator Services and Directory Assistance" is the Network Element that provides two types of functions: Operator Services and Directory Assistance, each of which is described below.

2.9.6.1 "Operator Services"

2.9.6.1.1 Inward Operator Services

Inward Operator Services enables the COVAD end user or its operator service provider to be connected to the BELL ATLANTIC Traffic Operation Position Systems ("TOPS") office(s) for the purpose of providing operator services to their end users. There are two types of Inward Operator Services:

- (i) Busy Line Verification ("BLV"):
BLV is an option where, at the request of COVAD's end user or its operator service provider, a BELL ATLANTIC operator will attempt to determine the status of an exchange service line (e.g., conversation in progress, available to receive a call or out of service) and report to COVAD's end user or its operator service provider.

- (ii) Busy Line Verification/Interrupt ("BLV/I")
BLV/I is an option where, at the request of COVAD's end user or its operator service provider, a BELL ATLANTIC operator determines and reports that a conversation is in progress on an exchange service line and subsequently interrupts such conversation to request that the conversation be terminated so that COVAD's end user can attempt to complete a call to the line.

Inward Operator Services are provided over

trunk groups ordered by COVAD or its alternate operator service provider to the BELL ATLANTIC TOPS switch(es) as specified by BELL ATLANTIC.

Inward Operator Services cannot be provided on ported telephone numbers; telephone number which forward calls using Call Forwarding Variable service features.

- a) BELL ATLANTIC will provide BLV and BLV/I for telephone numbers provided in its operating territory.
- b) The BELL ATLANTIC operator will respond to one telephone number per call on requests for BLV or BLV/I.
- c) BELL ATLANTIC will designate which TOPS switch(es) services which NXXs and make such information available to COVAD.
- d) COVAD shall order Inward Operator Services as set forth in this Section.
- e) COVAD and its customer shall indemnify and save BELL ATLANTIC harmless against all claims that may arise from either party to the interrupted call or any other person.

Rates and Charges for Inward Operator Services are set forth in Part IV.

2.9.6.1.2 Operator Service ("OS")

Under this option, BELL ATLANTIC shall provide for the routing of Operator Services ("OS") calls dialed by COVAD subscribers directly to either the COVAD Operator Services platform or to the BELL ATLANTIC Operator Services platform as specified by COVAD.

BELL ATLANTIC will offer OS to COVAD customers served by COVAD switches over separate trunk groups ordered or provided by COVAD to the BELL ATLANTIC TOPS switch(es) as specified by BELL ATLANTIC.

Access to the BELL ATLANTIC OS platform from COVAD's local switch requires that COVAD utilize Feature Group C Modified Operator Services Signaling. The Interoffice Transmission Facility mileage rate for the facility will be based on airline mileage using V&H coordinate methods from the COVAD location to the nearest BELL ATLANTIC TOPS. Trunk terminations at the TOPS switch(es) require COVAD to purchase trunk ports at rates specified in the Pricing Schedule.

For each trunk group, COVAD must indicate the branding option selected as set forth in Sections 19.2.2 (a), (b), and (c) preceding. BELL ATLANTIC also provides COVAD, using the unbundled local switching element, access to this optional service either through dedicated IOF and trunk ports or on shared operator service trunks between the end office in which they have unbundled local switching ports and the TOPS switches. Additional per minute of use (MOU) local switching charges will apply for all calls which interconnect from the unbundled local switching ports to the BELL ATLANTIC TOPS at rates set forth in Part IV.

2.9.6.1. 0+ Mechanized Operator Calls (Calling Card, Collect, Bill to Third Number):

This option is available for COVAD to provide their end user the ability, through the mechanized BELL ATLANTIC operator interface, to complete calls via 0+ dialing with alternate billing capabilities without live operator assistance. Alternate billing call completions can be Calling Card, Collect or Bill to Third Number.

0+ Mechanized calls may be provided over the same DA trunk groups which establish interconnection from the COVAD switch or the trunk groups which provide interconnection from the COVAD unbundled local switching

line ports to the BELL ATLANTIC TOPS.

Rates for requests for 0+ Mechanized Calls will be billed to COVAD and are set forth in Part IV.

In addition, for calls originating from a facilities-based COVAD switch or for calls from COVAD unbundled local switching line ports, there will be charges to terminate the call from the TOPS tandem to the called party. These include the per minute of use Unbundled Tandem Transport Charges ("UTTC") assessed for each call transported between the TOPS tandem and the end office, the per minute of use Tandem Transit Switching Charge ("TTSC") assessed for each call that traverses a BELL ATLANTIC tandem switch, and the appropriate per minute of use charges for reciprocal compensation ("UNRCC" or "UCRCC") depending on the terminating end office switch, as set forth in Part IV.

2.9.6.1.4

0- Operator Handled Calls (Calling Card, Collect, Bill to Third Number)

This option is available for COVAD to provide their end user, through the BELL ATLANTIC operator, the ability to complete intraLATA calls via 0- dialing with alternate billing capabilities and live operator assistance. Alternate billing call completions can be Calling Card, Collect or Bill to Third Number, Station to Station and Person to Person.

0- Operator Handled Calls may be provided over the same DA trunk groups which establish interconnection from the COVAD switch or the trunk groups which provide interconnection from the COVAD unbundled local switching line ports to the BELL ATLANTIC TOPS.

Rates for requests for 0- Operator Handled Calls will be billed to COVAD and are set forth in Part IV. In addition, for calls originating from a facilities-based COVAD switch or for calls

from COVAD unbundled local switching line ports, there will be charges to terminate the call from the TOPS tandem to the called party. These include the per minute of use Unbundled Tandem Transport Charges ("UTTC") assessed for each call transported between the TOPS tandem and the end office, the per minute of use Tandem Transit Switching Charge ("TTSC") assessed for each call that traverses a BELL ATLANTIC tandem switch, and the appropriate per minute of use charges for reciprocal compensation ("UNRCC" or "UCRCC") depending on the terminating end office switch, as set forth in Part IV.

2.9.6.1.5 Operator Emergency Bulletin Service

This option provides COVAD with emergency numbers of police, fire, ambulance and Public Safety Answering Points (PSAP) in the BELL ATLANTIC serving area so that COVAD operators can connect callers directly to the proper emergency bureaus.

The BELL ATLANTIC Operator Emergency Bulletin Service lists the emergency, police, fire, ambulance and PSAP telephone numbers by municipality and in alphabetical order for each of the areas served by BELL ATLANTIC.

Operator Emergency Bulletin Service is available for use by COVAD operators for the sole purpose of assisting callers in reaching an emergency bureau.

Operator Emergency Bulletin Service is a copy of BELL ATLANTIC's own emergency bulletin.

This agreement includes one annual copy of the bulletin plus periodic updates during the year. Independent telephone companies emergency numbers are not included.

Rates and charges for Operator Emergency

Bulletin service are set forth in Part IV.

2.9.6.1.6 Operator Passthrough Service

This option provides COVAD's end users with access to operators of their Presubscribed Interexchange Carriers ("IC") for operator assisted call completion. This option applies only when the Presubscribed IC provides Operator Services for COVAD's end users for calls originating from a particular LATA and is capable of receiving calls passed through it by BELL ATLANTIC in that LATA.

BELL ATLANTIC will, when requested by COVAD's end user, connect that end user to a specified IC for operator call completion provided that IC offers operator services in that end user's originating LATA and is capable of receiving calls passed through to it by BELL ATLANTIC in that LATA.

If the IC does not provide Operator Services for COVAD's end user, at the option of the IC, BELL ATLANTIC will provide COVAD's end user with access to an IC designated Operator Services Provider or to a BELL ATLANTIC provided announcement which will direct COVAD's end user to contact their Presubscribed IC for dialing instructions.

The Operator Passthrough charge is applied on an operator work second basis, and rated using the 0-Operator Handled calls in Part IV.

COVAD will be assessed this charge on calls that are passed through to either the Presubscribed IC's operator, or a BELL ATLANTIC provided recording indicating that the IC does not provide service in that area.

Rates and charges applied to Operator Passthrough Service are set forth in Part IV.

2.9.6.2 Directory Assistance

BELL ATLANTIC will offer Directory Assistance ("DA") service to COVAD's customers served by COVAD's own switch over separate trunk groups ordered or provided by COVAD to the BELL ATLANTIC TOPS switch(es) as specified by BELL ATLANTIC. Access to the BELL ATLANTIC DA platform from COVAD's local switch requires that COVAD utilize Feature Group C ("FG-C") Modified Operator Services Signaling. The Interoffice Transmission Facility ("IOF") mileage rate for the facility will be based on airline mileage using V&H coordinate methods from the COVAD location to the nearest BELL ATLANTIC TOPS. Trunk terminations at the TOPS switch(es) require COVAD to purchase trunk ports at rates specified in Part IV. For each trunk group COVAD must indicate the DA option selected as set forth in 19.2.2 (a), (b) and (c) immediately following. BELL ATLANTIC also provides COVAD, using the unbundled local switching element, access to this optional service either through dedicated IOF and trunk ports or on shared operator service trunks between the end office in which they have unbundled local switching ports and the TOPS switches. Additional per minute of use ("MOU") local switching charges will apply for all calls which interconnect from the unbundled local switching ports to the BELL ATLANTIC TOPS as described in Part IV.

This option provides COVAD end users access to Telephone Directory Assistance operators via 411, 555-1212, or 1+ (NPA) 555-1212 dialing. Rates for requests for Directory Assistance will be billed to COVAD and are set forth in Part IV. There are no Directory Assistance call allowances provided to COVAD or their end users.

2.9.6.2.1 Directory Assistance with Branding

This service allows COVAD to select only one of the three options as follows:

(a) COVAD may provide BELL ATLANTIC with a COVAD branded, introductory Directory Assistance and Operator Services announcement which will be played for all COVAD end users completing DA or Operator Services calls over the trunk group to the BELL

ATLANTIC TOPS.

(b) COVAD may request BELL ATLANTIC branded announcement.

(c) COVAD may request an unbranded, generic announcement.

This message may be a maximum of eighteen (18) seconds and may be recorded by COVAD or, at COVAD's request, by BELL ATLANTIC. A minimum of two (2) audio cassette recordings of the COVAD branding announcement must be forwarded to BELL ATLANTIC. Rates for requests for Directory Assistance with branding will be billed to COVAD and are set forth in Part IV.

2.9.6.2.2

Directory Assistance Call Completion (DACC)

This option provides for automatic connection of a COVAD end user calling BELL ATLANTIC DA to the published telephone number requested. After the BELL ATLANTIC DA operator provides the requested number, a recorded service message will offer to connect the caller to that number for a specified additional charge. The caller can accept the offer for DACC by depressing a button (touch tone) or responding by voice (dial), as instructed by the voice message. The DACC charge will apply as set forth in Part IV. In addition, for calls originating from a facilities-based COVAD switch or for calls from COVAD unbundled local switching line ports, there will be charges to terminate the call from the TOPS tandem to the called party. These include the per minute of use Unbundled Tandem Transport Charges (UTTC) assessed for each call transported between the TOPS tandem and the end office, the per minute of use Tandem Transit Switching Charge (TTSC) assessed for each call that traverses a BELL ATLANTIC tandem switch, and the appropriate per minute of use charges for reciprocal

compensation (UNRCC or UCRCC) depending on the terminating end office switch, as set forth in Part IV.

DACC is available to COVAD residence and business customers and from public telephones on a collect, bill to third number or calling card basis. The charge appropriate to the billing option used will apply in addition to the DACC charge.

DACC is available with all telephone numbers in the BELL ATLANTIC DA database except:

- non-published telephone numbers
- interLATA numbers
- 700, 800 and 900 numbers

When a caller requests more than one number for Directory Assistance, DACC is offered only for the first eligible listing that was selected by the operator.

The DACC charge applies only to calls actually completed.

The DACC charge will be credited for completion of calls to the wrong number, incomplete connections or calls with unsatisfactory transmission as set forth in Section 2.9.6.2.3 following.

Rates for requests for DACC will be billed to COVAD as set forth in Part IV.

2.9.6.2.3 Directory Assistance Credits

A credit allowance will apply to COVAD for directory inaccessibility, wrong numbers, cut-offs or poor transmission. When the COVAD end user reports to the BELL ATLANTIC directory assistance operator such a call and the number requested, the number provided and the reason the number provided is

incorrect, the number of calls for which a credit will apply will be developed by the BELL ATLANTIC DA operator and credited to COVAD identifying the specific COVAD end user to whom the credit applies.

2.9.6.2.4 Direct Access to Directory Assistance ("DADA")

Direct Access to Directory Assistance ("DADA") is a database service that provides for access to BELL ATLANTIC listings by a COVAD operator. The DADA database is a physically distinct entity from the BELL ATLANTIC DA database, populated with identical listing data, and updated from the same source on a daily basis.

COVAD is required to arrange for interconnection to the database. BELL ATLANTIC will interconnect at any technically feasible point designated by COVAD. BELL ATLANTIC will provide COVAD with a User Guide for training its agents.

Rates and Charges for DADA are set forth in Part IV.

2.9.6.3 Customized Routing will be provided in accordance with the PSC No. 916 Tariff.

2.9.7 "Signaling Systems and Call-Related Databases"

2.9.7.1 "Signaling Link Transport" is a set of two or four dedicated 56 Kbps transmission paths between Signaling Points of Interconnection (SPOI) mutually agreed to by the Parties that provides appropriate physical diversity.

2.9.7.2 "Signaling Transfer Points" is a signaling network function that includes all of the capabilities provided by the signaling transfer point switches (STPs) and their associated signaling link ports which enable the exchange of SS7 messages among and between switching elements, database elements

and other signaling transfer points. This function does not include the administration and translation function which BELL ATLANTIC will perform upon COVAD's request.

2.9.8 "Service Control Points (SCPs)"/"Databases"

- 2.9.8.1** "Databases" as used herein are the unbundled Network Elements that typically provide the functionality for storage of, access to, and manipulation of information required to provide a particular service or capability.
- 2.9.8.2** A "Service Control Point" (SCP) is a specific type of Database Network Element deployed in a Signaling System 7 (SS7) network that executes service application logic in response to SS7 queries sent to it by a switching system also connected to the SS7 network. SCPs may also utilize interfaces to allow for provisioning, administration and maintenance of subscriber data and service application data (e.g., an 800 database stores Customer record data that provides information necessary to route 800 calls).
- 2.9.8.3** "Service Management Systems" (SMS) permits the creation, modification or updating of information in call-related databases. SMS shall be provided by BELL ATLANTIC to COVAD in the same manner and method that BELL ATLANTIC provides for its own access to SMS. BELL ATLANTIC shall provide COVAD with all information necessary to correctly enter or format for entry the information relevant for input into the particular BELL ATLANTIC SMS.
- 2.9.8.4** "Advanced Intelligent Network" (AIN) database as used herein means a Service Control Point providing programmed call-processing information for various services in response to specific queries generated by switch-based triggers.

2.10 Operations Support Systems Functions. See Section 12 of the General Terms and Conditions of this Agreement.

3. Other Requirements

3.1 To the extent required by Applicable Law, BELL ATLANTIC may combine unbundled Network Elements at rates and charges to be determined on an individual case basis.

3.2 COVAD agrees that, in order to allow BELL ATLANTIC to properly size its resources, COVAD will provide BELL ATLANTIC with COVAD's projected demand requirements for particular unbundled Network Elements prior to ordering such unbundled Network Elements in a particular geographic area. The demand projections provided by COVAD will include, but shall not be limited to, forecasts of: (1) the volume of unbundled Network Elements; (2) any significant number of orders for any unbundled Network Elements; and (3) complex orders for unbundled Network Elements. BELL ATLANTIC agrees, however, that COVAD shall not be required by this Section 3.2 to provide detailed forecasts of every specific order, unbundled Network Element, or Customer specific bid. The Parties agree to participate in joint network planning and large job planning meetings as required. COVAD will be considered the Customer for each unbundled Network Element.

3.3 Intentionally Omitted

3.4 The following additional terms shall apply to COVAD's purchase and BELL ATLANTIC's provision of unbundled Network Elements.

3.4.1 Intentionally Omitted

3.4.2 BELL ATLANTIC agrees to unbundled its SS7 network to convey any type of message (currently provided or to be provided in the future when and where it becomes available in the BELL ATLANTIC network) as required by the Order (i.e., at an STP) between any and all signaling points necessary for the provision of those services. The BELL ATLANTIC signaling network will provide access to all unbundled Network Elements connected to it and will support fully the functions of all unbundled Network Elements connected to it in support of these services as specifically included in this Agreement and necessary for the mutual provision of said services. This explicitly includes the use of the BELL ATLANTIC signaling network to convey transient messages to another carrier connected to BELL ATLANTIC's network in a manner that permits BELL ATLANTIC to convey such messages. For example, to the extent permitted by law, BELL ATLANTIC agrees not to block transient TCAP messages. BELL ATLANTIC agrees to (i) allow

COVAD freedom to select signaling points of interconnection, subject to the capacity of the BELL ATLANTIC network and other network considerations, (ii) unbundle dedicated transport for signaling links from the BELL ATLANTIC SS7 network and to satisfy physical diversity requirements based on the capacity and any measuring limitations of its SS7 network on the same terms and conditions that BELL ATLANTIC provides to itself, (iii) enable call setup between COVAD local switching and signaling systems and the BELL ATLANTIC switching and signaling systems, (iv) support CLASS features between the COVAD local network and BELL ATLANTIC's network to the extent such compatibility exists on the Effective Date of this Agreement and thereafter as such compatibility may be expanded, and (v) provide the appropriate options to query BELL ATLANTIC databases via this inter-connection.

- 3.4.3 BELL ATLANTIC agrees to unbundle Tandem Switching in a manner that prevents the loss of any functionality when routing through the applicable tandem to the extent such functionality is provided for traffic routed through that tandem on the Effective Date of this Agreement and thereafter during the term or any renewal term of this Agreement. BELL ATLANTIC agrees to preserve CLASS features and Caller ID as traffic is processed, to the extent the BELL ATLANTIC network has the capability on the Effective Date of this Agreement and thereafter as such capability may be expanded, and to provide COVAD access to the BELL ATLANTIC E911 tandems. COVAD acknowledges that certain CLASS features may not be passed between certain switch types which do not have such technical capabilities in the BELL ATLANTIC network.
- 3.4.4 BELL ATLANTIC agrees to provide COVAD full cooperation and support to ensure COVAD's Customers are able to reach a PSAP. BELL ATLANTIC will provide COVAD data on the type of emergency service (e.g., Basic 911, E911) that exists throughout the NY Region, as well as any geographical differences. COVAD agrees that it is responsible for initiating and maintaining its own relationships with PSAPs, and for any end user payments to townships, counties and municipalities associated with 911/E911 services. BELL ATLANTIC agrees, however, that it will endeavor to assist COVAD in establishing relationships with PSAPs.
- 3.4.5 BELL ATLANTIC shall perform testing and trouble isolation of all unbundled Network Elements provided by BELL ATLANTIC, except for the Local Loop and line ports.

3.4.6 Within 6 months after the Effective Date, the Implementation Team described in Attachment 2 ("Operations Plan and Implementation Team") shall begin to consider supplementing the Operations Plan with more detailed specifications and technical requirements for the unbundled Network Elements.

4. MLT Testing

Except in exceptional circumstances, as stated below, when a COVAD customer served by COVAD using an unbundled Network Element Local Loop or reports a service problem to COVAD, COVAD shall perform Mechanized Loop Testing (MLT) on the Local Loop and line port prior to reporting the service problem to BELL ATLANTIC. The Parties will work cooperatively to develop a list of exceptional circumstances in which COVAD need not perform an MLT test, which shall include, but not be limited to circumstances in which the service problem is due to a visually or otherwise readily identifiable service problem (e.g., a downed drop wire) or the applicable BELL ATLANTIC systems needed to perform an MLT test are not operational. In addition, BELL ATLANTIC, in its discretion, may perform MLT testing to diagnose a trouble. BELL ATLANTIC will maintain all unbundled Network Elements provided by BELL ATLANTIC to COVAD, including but not limited to the Local Loop (and line ports).

EXHIBIT A to Part II

Bona Fide Request Process

1. The following process shall be used to promptly consider and analyze requests by COVAD for unbundled Network Elements required to be provided under the Act which are not specifically identified in this Agreement. These requests by COVAD shall hereinafter be referred to as "Bona Fide Requests."
2. A Bona Fide Request shall be submitted in writing and shall include a technical description of each requested unbundled Network Element.
3. Within ten (10) business days of receipt, BELL ATLANTIC shall acknowledge receipt of the Bona Fide Request.
4. Except under extraordinary circumstances, within thirty (30) days of its receipt of a Bona Fide Request, BELL ATLANTIC shall provide to COVAD a preliminary analysis in writing of such Bona Fide Request (hereinafter referred to as a "Preliminary Analysis") at no charge to COVAD. The Preliminary Analysis shall (i) state whether the unbundled Network Element requested by COVAD is readily or currently available, and if so, confirm that BELL ATLANTIC will promptly offer access to the unbundled Network Element or (ii) provide an explanation that access to the unbundled Network Element is not technically feasible or available and/or that the request does not qualify as an unbundled Network Element that is required to be provided by BELL ATLANTIC under the Act. In the case of clause (ii) above, the Parties shall undertake good faith negotiations to redefine the request, and in the event of impasse either Party may seek relief pursuant to the Dispute Resolution Process set forth in Section 16 of the General Terms and Conditions of this Agreement.
5. Once the Parties have agreed that the provision of an unbundled Network Element requested in the Bona Fide Request is technically feasible and otherwise qualifies under the Act, if COVAD wishes BELL ATLANTIC to proceed with developing the Bona Fide Request, it shall submit a written request for a quote and provide payment to BELL ATLANTIC for the preparation of such quote (hereinafter referred to as a "BFR Quote"). Within 90 days of such request by COVAD to proceed and payment therefor, BELL ATLANTIC shall complete the development of the BFR Quote for the unbundled Network Element requested in the Bona Fide Request, including availability, applicable prices and installation intervals.
6. Unless the Parties otherwise agree, the unbundled Network Element requested must be priced in accordance with Section 252(d)(1) of the Act.
7. Within ninety (90) days of its receipt of the BFR Quote, COVAD must confirm its

order for the Bona Fide Request pursuant to the BFR Quote or seek relief pursuant to the Dispute Resolution Process set forth in Section 16 of the General Terms and Conditions of this Agreement.

8. If a Party believes that the other Party is not requesting, negotiating or processing a Bona Fide Request in good faith, or disputes a determination, or price or cost quote, or is failing to act in accordance with Section 251 of the Act, such Party shall seek relief pursuant to the Dispute Resolution Process set forth in Section 16 of the General Terms and Conditions of this Agreement.
9. COVAD may cancel its Bona Fide Request at any time upon written notice to BELL ATLANTIC, subject to the following: (i) if such cancellation notice is received after the submission by BELL ATLANTIC to COVAD of the Preliminary Analysis, but before COVAD requests a BFR Quote, COVAD shall not be liable to BELL ATLANTIC for reimbursement of any costs incurred by BELL ATLANTIC and (ii) if such cancellation notice is received after COVAD submits its request for a BFR Quote, but before the BFR Quote is rendered by BELL ATLANTIC to COVAD, COVAD shall be liable to BELL ATLANTIC for reimbursement of all actual costs incurred by BELL ATLANTIC in connection with developing such BFR Quote up until its receipt of such notice of cancellation; provided, however, that if such notice of cancellation is received after the receipt by COVAD of the BFR Quote, the amount for which COVAD shall be liable pursuant to clause (ii) of this paragraph 9 shall not exceed the lesser of the actual costs incurred by BELL ATLANTIC or the estimate in the BFR Quote plus 20%.

PART III: SERVICE DESCRIPTION – ANCILLARY FUNCTIONS

1. Intentionally Omitted

2. Collocation

2.1 Definition

Subject to the availability of space, physical collocation ("collocation") is the right of COVAD to obtain dedicated space, power and other associated resources as provided herein in the BELL ATLANTIC Local Serving Office (LSO) serving wire centers and tandem offices which are specified in NECA 4, as well as all other BELL ATLANTIC premises as required under the Act and the Order ("Collocation Premises"), and to place equipment in such spaces to interconnect with the BELL ATLANTIC network services and/or unbundled Network Elements and/or interconnect to any other interconnector located in such Collocation Premises through BELL ATLANTIC facilities. Subject to Section 7.4 of the General Terms and Conditions of this Agreement, BELL ATLANTIC shall provide to COVAD collocation space necessary for the placement of equipment necessary for interconnection and for access to unbundled Network Elements according to applicable BELL ATLANTIC tariffs, including but not limited to P.S.C. No. 900 Tariff, as in effect from time to time and the terms of this Agreement. On COVAD's written request, BELL ATLANTIC will provide virtual collocation, even if physical collocation is available, but subject to and in accordance with applicable tariffs and the terms of this Agreement; provided, however, that BELL ATLANTIC agrees not to voluntarily file any tariff provision with the Commission that is inconsistent with the position that virtual collocation is available upon request even if physical collocation is also available. Except for the provisions of Section 2.4.23 of this Part III, the provisions of this Part III shall not be applicable to collocation for solely interstate purposes. Except for the provisions of Section 2.4.23 of this Part III, if COVAD requests collocation for solely (100%) interstate purposes, the same shall be governed by applicable FCC tariffs, and whether a purpose constitutes interstate or intrastate shall be determined according to applicable FCC rules and tariffs.

2.2 Technical Requirements

2.2.1 BELL ATLANTIC shall provide, upon request by COVAD, a license to occupy space to meet COVAD's needs for placement of equipment for interconnection, or access to unbundled Network Elements pursuant to the requirements in this Agreement.

- 2.2.2 BELL ATLANTIC shall provide intraoffice facilities (e.g., DS0, DS1, and DS3 terminations) permitting electrical handoffs as requested by COVAD to meet COVAD's need for placement of equipment, interconnection, or provision of service. At such time that OC3, OC12, OC48, and STS1 intraoffice facility terminations become available in the Collocation Premises, they shall be made available to COVAD for its fiber handoffs.
- 2.2.3 The standard hours for COVAD equipment and cable installations in the collocated space shall be 9:00 AM to 5:00 PM, Monday through Friday. In those instances where COVAD may reasonably require expanded equipment and cable installation hours, it shall make such request not less than two business days prior to the requested date of access, which request shall be promptly reviewed by BELL ATLANTIC and with respect to which BELL ATLANTIC shall not unreasonably withhold its consent. Any such outside-standard-hours access to the collocated space or other associated BELL ATLANTIC space for equipment installation is restricted to the collocation area and the entire cable route, and may require COVAD's payment of costs incurred by BELL ATLANTIC including costs for a security guard or escort personnel. BELL ATLANTIC shall provide COVAD with written security rules and regulations prior to COVAD's commencement of installation at the collocated space.
- 2.2.4 BELL ATLANTIC shall not be obligated to permit collocation of switching equipment in BELL ATLANTIC facilities. To the extent the Commission determines in instances where COVAD has demonstrated to the Commission that Remote Switching Modules ("RSMs") or Remote Line Modules ("RLMs") are used for interconnection or access to unbundled Network Elements, COVAD may locate such RSMs or RLMs in collocated space, on a space available basis for use in conformance with all applicable FCC orders. All RSMs and RLMs installed at BELL ATLANTIC facilities shall be installed consistent with BELL ATLANTIC requirements as set forth in Sections 2.2.31 through 2.2.34 of this Part III for such equipment (e.g., grounding requirements set forth in Appendix D). COVAD may collocate Digital Subscriber Line Access Multiplexers (DSLAMs) in its collocated space subject to the requirements of this Part III.
- 2.2.5 BELL ATLANTIC shall provide interconnection of COVAD to other

carriers who have collocated space within the same BELL ATLANTIC Collocation Premises (e.g., BELL ATLANTIC shall not require COVAD to interconnect with other carriers outside the BELL ATLANTIC Collocation Premises). Such COVAD to other carrier interconnection shall be accomplished via BELL ATLANTIC transmission facilities the price for which shall be established by applicable tariffs, including but not limited to P.S.C. No. 900 Tariff or, if there shall be none, established on an individual case basis.

- 2.2.6 COVAD may select its own vendors for all required engineering and installation services associated with its collocated equipment (e.g., BELL ATLANTIC shall not require COVAD to utilize BELL ATLANTIC's internal engineering or installation work forces for the engineering and installation of COVAD's collocated equipment). COVAD's vendors shall be (i) on the then current BELL ATLANTIC approved vendors' list which will be provided by BELL ATLANTIC to COVAD upon request, or (ii) considered by BELL ATLANTIC for inclusion in such list, upon COVAD's request.
- 2.2.7 BELL ATLANTIC shall provide under tariff basic telephone service with a connection jack when ordered by COVAD from BELL ATLANTIC for the collocated space for administrative purposes. Upon COVAD's request, this service shall be available at the COVAD collocated space within the same time frame in which BELL ATLANTIC provides basic telephone service to its end-user Customers served from the same central office.
- 2.2.8 BELL ATLANTIC shall provide adequate "stumble" lighting, ventilation, power, heat, air conditioning, and other toll grade environmental conditions suitable for transmission equipment for COVAD's space and equipment in compliance with Bell Communication Research (Bellcore) Network Equipment- Building System (NEBS) standards TREOP000063. COVAD may install its own AC/DC rack lighting in the collocation space, subject to applicable standards. Notwithstanding BELL ATLANTIC's obligation herein to provide "stumble" lighting only, COVAD shall receive from BELL ATLANTIC the same level of any greater lighting which BELL ATLANTIC may provide to any other Telecommunications Carrier at the same Collocation area within the same Collocation Premises.
- 2.2.9 To the extent that it has and makes such facilities available to its own

employees, in emergency situations, BELL ATLANTIC shall provide access to washdown facilities within the Collocation Premises on a twenty-four (24) hours per day, seven (7) days per week basis for COVAD personnel and its designated agents. COVAD employees and designated agents shall have standard access to restrooms in the Collocation Premises, where available. If desired, COVAD shall provide its own portable eyewash stations within the collocated space.

2.2.10 Subject to its availability and technical feasibility, BELL ATLANTIC shall provide all ingress and egress of fiber and power cabling to COVAD collocated spaces in compliance with COVAD's cable diversity requirements. The specific level of diversity compliance and COVAD diversity requirements for each site or unbundled Network Element will be provided in the collocation request and, if BELL ATLANTIC determines that such compliance will result in added expense, COVAD shall be so advised and given an opportunity to decide whether or not it wishes to pay for said added expense.

2.2.11 BELL ATLANTIC shall ensure protection of COVAD's proprietary Customer information in accordance with the provisions of Section 18 of the General Terms and Conditions of this Agreement.

2.2.12 BELL ATLANTIC agrees that any collocation space furnished to COVAD hereunder will be in compliance with OSHA requirements. In the event COVAD becomes aware of any violation or noncompliance with OSHA by BELL ATLANTIC in any collocation area, COVAD will so notify BELL ATLANTIC and BELL ATLANTIC shall remedy such situation as promptly as possible. In the event COVAD requests collocation space in Collocation Premises known to BELL ATLANTIC to contain asbestos or other similar environmental condition, BELL ATLANTIC shall give prompt verbal notification thereof to any one of the COVAD contacts provided to BELL ATLANTIC, as required by subsection 2.2.20.5.

2.2.13 Except in the case of emergency situations, BELL ATLANTIC shall provide COVAD with notice five (5) business days prior to those instances where BELL ATLANTIC or its subcontractors will engage in significant work activities that may affect COVAD's collocation in the general area of the collocated space occupied by COVAD, or in the general area of the AC and DC power plants which support COVAD equipment. BELL ATLANTIC will endeavor to inform COVAD by

telephone of any emergency-related activity that BELL ATLANTIC or its subcontractors may be performing in the general area of the collocated space occupied by COVAD, or in the general area of the AC and DC power plants which support COVAD equipment. Notification of any emergency-related activity shall be made as soon as possible so that COVAD can take any action required to monitor or protect its service. COVAD shall attach to its collocation space cage in a visible and easily accessible location the COVAD methods of procedure (e.g., name and contact telephone number(s)) for 24-hour contacts to be made by BELL ATLANTIC to COVAD under this subsection.

2.2.14 BELL ATLANTIC shall prepare or cause to be prepared a basic drawing of the collocation space, which drawing shall specifically include (i) the dimensions of such space, (ii) the location and proximity of such space to any walls and other structures, (iii) the location of doors, ground bars and AC convenience outlets, (iv) the location of the BELL ATLANTIC Point of Termination Bays, and (v) to the best of its knowledge without independent investigation, any physical obstructions which may have a material adverse effect upon the construction of the requested cage; provided, however, BELL ATLANTIC will promptly notify COVAD in the event its becomes aware of obstructions not otherwise noted previously. Such drawings shall be provided by BELL ATLANTIC at a time mutually agreed to by the Parties.

2.2.15 Except as otherwise provided in Section 2.4.57 below, BELL ATLANTIC shall construct the collocated space in accordance with COVAD's reasonable request regarding location of COVAD collocation space cable access, ground bars, doors, and convenience outlets which construction shall be consistent with BELL ATLANTIC's engineering standards for its own similar requirements. Convenience outlets will consist of 110 volts/20 amps feeding two duplex outlets per 100 square feet of collocated space. Any COVAD request which cannot be accommodated by BELL ATLANTIC will be indicated on the final drawings prepared for such collocation space in accordance with this Part III.

2.2.16 COVAD and BELL ATLANTIC will complete an acceptance walk-through of all collocated space requested from BELL ATLANTIC. Exceptions to the final drawings (as such drawings may be modified by

mutual agreement of the Parties) and in the Application for Collocation that are noted by COVAD during this acceptance walk-through shall be corrected by BELL ATLANTIC generally within five (5) days after the walk-through but in no case more than ten (10) days thereafter except in those instances where significant space modifications are required (e.g., cage reconstruction). The correction of these exceptions from the original collocation request, which exceptions were not subsequently agreed to by COVAD, shall be at BELL ATLANTIC's expense.

2.2.17 After acceptance of COVAD's request for collocated space the Parties shall mutually agree on a date for BELL ATLANTIC to conduct a walk-through of the cable routes to be held prior to commencement of collocated space construction.

2.2.18 BELL ATLANTIC shall provide detailed power cabling connectivity information including the sizes and number of power feeders to COVAD within five (5) business days of BELL ATLANTIC's acceptance of the power provisioning bid associated with the furnishing of collocated space in accordance with COVAD's request therefor.

2.2.19 Intentionally Omitted.

2.2.20 COVAD shall request access to Collocation Premises for the purposes set forth in Section 2.2.1 of this Part III in accordance with the following procedures:

2.2.20.1 In order to request construction in collocated space, COVAD shall submit to BELL ATLANTIC COVAD's Application for Collocation (Appendix B) and the applicable BELL ATLANTIC tariff fee(s) (the date of receipt by BELL ATLANTIC of such Application and fee(s) being hereinafter referred to as the "Start Date").

(A) Within eight (8) business days of receipt by BELL ATLANTIC of COVAD's Application (provided the same shall be materially complete) and applicable tariff fee, BELL ATLANTIC shall respond to such Application by indicating whether or not the request can be accommodated or by providing COVAD with a Collocation Schedule which shall set forth recurring

charges and estimated design and construction costs and providing results of a site survey.

- (B) Within TWO (2) business days of receipt by COVAD of such detailed costs estimate, COVAD shall in writing accept or decline BELL ATLANTIC's proposal and, if it shall accept such proposal, it shall concurrently with such acceptance provide BELL ATLANTIC with (i) a payment equal to 50% of the total estimated cost or such other payment as shall be required in accordance with BELL ATLANTIC's applicable tariff and (ii) an Insurance Certificate in the form of Appendix C.

- (C) Except in the event that COVAD changes its Application for Collocation requirements after they have been accepted by BELL ATLANTIC and such change would, in the reasonable judgment of BELL ATLANTIC, cause a construction or other delay which would affect the turnover of collocated space (in which case the penultimate sentence of this subparagraph shall apply), or in the event of Special Circumstances (as defined below) detailed by BELL ATLANTIC for COVAD, and subject to the circumstances contemplated by Section 14 (Force Majeure) of the General Terms and Conditions of this Agreement and the limitations set forth in Exhibit A of this Part III, the collocated space shall be constructed, made ready and turned over by BELL ATLANTIC to COVAD within seventy-six (76) business days after the Start Date or, when COVAD submits three or more collocation applications in any one month, as agreed by the Parties but in any event within one hundred twenty (120) business days from the Start Date. In the event of Special Circumstances, such respective deadlines shall be extended by no more than an additional fifteen (15) business days (unless otherwise mutually agreed to by the Parties). The turnover interval shall be customized to reflect the specific collocated space design and construction work to be done. In those instances where COVAD changes its requirements which will affect the turnover of collocated space, the interval for construction and turnover of the collocated space shall be extended to

reflect these changes upon mutual agreement of the Parties. For purposes of this subparagraph, the term "Special Circumstances" shall mean special, unusual or unanticipated conditions or circumstances arising out of or required by COVAD's Application for Collocation (excluding changes made by COVAD to such Application after such Application has been accepted by BELL ATLANTIC) which could, in the reasonable judgment of BELL ATLANTIC, cause a construction or other delay in the turnover of collocated space including, by way of illustration and without limitation, major construction obstacles, asbestos abatement procedures or uncustomary modifications to the Collocation Premises.

2.2.20.2 Any rights and remedies which COVAD may have as a result of a failure by BELL ATLANTIC to comply with the collocation turnover requirements of Section 2.2.20.1 hereof shall be governed exclusively by the terms and conditions of this Agreement, including Exhibit A to this Part III.

2.2.20.3 Within five (5) business days after the approval by BELL ATLANTIC of COVAD's Application for Collocation and payment by COVAD of the appropriate application fee(s), BELL ATLANTIC shall provide the following information to COVAD to the extent not previously provided by BELL ATLANTIC:

2.2.20.4 Work restriction guidelines;

2.2.20.5 BELL ATLANTIC technical publication guidelines, if any, that impact the design of the COVAD collocated equipment. The Parties also agree that during the Application for Collocation review, cage construction and equipment installation processes each Party will provide the other with a single point of contact name and telephone number. Thereafter, each Party will provide the other with contact names and telephone numbers to the extent requested by the other Party and to the extent necessary to complete such processes and for ongoing collocation purposes; and

2.2.20.6 Escalation process for the BELL ATLANTIC representatives (names, telephone numbers and the escalation order) for any

disputes or problems that might arise pursuant to COVAD's collocation.

2.2.21 "Power," as referenced in this Part III, refers to any electrical power source supplied by BELL ATLANTIC for COVAD equipment. It includes all superstructure, infrastructure, and overhead facilities, including, but not limited to, cable, cable racks and bus bars. BELL ATLANTIC will supply power to support COVAD equipment at equipment specific DC voltage ranges. At a minimum, BELL ATLANTIC shall supply power to COVAD at parity with that provided by BELL ATLANTIC to itself for similar equipment requirements or to any third party. If BELL ATLANTIC performance, availability, or restoration falls below industry standards set forth in subsections 2.3.5 through 2.3.7 herein, BELL ATLANTIC shall bring itself into compliance with such industry standards as soon as technologically feasible.

2.2.21.1 Central office power supplied by BELL ATLANTIC into the COVAD equipment area, shall be supplied in the form of DC power feeders (cables) on cable racking into the designated COVAD equipment area. The DC power feeders (cables) shall support the requested quantity and capacity of COVAD equipment within acceptable industry standards. The termination location shall be as requested by COVAD in the collocation space.

2.2.21.2 For a fee to be set forth in the applicable Collocation Schedule (Appendix A) and subject to payment of any amounts required pursuant to Section 2.4.20, BELL ATLANTIC shall provide power as requested by COVAD and where technically feasible, to meet COVAD's need for placement of equipment, interconnection, or provision of service.

2.2.21.3 The BELL ATLANTIC power equipment supporting COVAD's equipment shall:

2.2.21.3.1 Comply with applicable industry standards (e.g., Bellcore, NEBS and IEEE) or manufacturer's equipment power requirement specifications for equipment installation, cabling practices, and physical equipment layout;

- 2.2.21.3.2 Have redundant power feeds with physical diversity furnished at additional cost to COVAD, and three (3) hour battery backup or, at minimum, at parity with that provided for similar BELL ATLANTIC equipment;
- 2.2.21.3.3 To the extent technically feasible, in the determination of the applicable BELL ATLANTIC vendor, and subject to the reimbursement by COVAD of any costs incurred by BELL ATLANTIC or its vendor, provide, when made available by the vendor at the particular Collocation Premises, the capability for direct access to real time alarm data arising from conditions that may impact COVAD equipment in the collocation space, including but not limited to power plant alarms specific to the BELL ATLANTIC power plants providing capacity to the batteries, distribution, fuses and bays within the COVAD collocation cage and environmental alarms. To the extent that access to alarm data is available in accordance with the terms of this subsection, BELL ATLANTIC shall also require that the vendor provide COVAD with all available information which COVAD may utilize to connect to the alarms to establish remote access to the COVAD work center provided that (i) with respect to any existing vendor arrangements, the vendor shall have agreed to make such information available to COVAD and (ii) with respect to any new vendor arrangements, the agreement with such vendor shall require such vendor to provide COVAD with such information (and BELL ATLANTIC agrees to request vendor to include such a provision in its agreement with BELL ATLANTIC).
- 2.2.21.3.4 BELL ATLANTIC will provide central office ground, connected to a ground electrode located at or on the outside of COVAD collocated space; the ground electrode shall be provided in accordance with accepted industry standards relating to central office grounding of transmission equipment (e.g., current standards provide that the ground electrode shall not be greater than 100 feet from the interconnector's cage); COVAD may affix a connection to the BELL ATLANTIC provided ground bar

in order to provide COVAD's own ground bar within the cage; and

2.2.21.3.5 For a fee to be set forth in the applicable Collocation Schedule (Appendix A), and where technically feasible, provide feeder capacity and quantity to support the ultimate equipment layout for COVAD equipment in accordance with COVAD's collocation request.

2.2.21.3.6 BELL ATLANTIC shall:

2.2.21.3.6.1 Pursuant to mutual agreement by the Parties, provide an installation sequence and access that reflects individual power requirements for each collocated space specifically with the understanding that COVAD typically desires that power be available before COVAD begins installing its equipment; BELL ATLANTIC agrees that when COVAD installs its own BDFB equipment in the collocation space, said equipment may be powered prior to the installation of other COVAD equipment;

2.2.21.3.6.2 Provide power plant alarms that adhere to BELL ATLANTIC standard practices;

2.2.21.3.6.3 Provide cabling that adheres to Bell Communication Research (Bellcore) Network Equipment-Building System (NEBS) standards TREOP000063; and

2.2.21.3.6.4 Provide Lock Out Tag Out and other electrical safety procedures and devices in conformance with OSHA or industry guidelines.

2.2.21.3.7 BELL ATLANTIC will provide COVAD with at least 24-hours prior notice of any scheduled AC or DC power work or related activity in the collocated facility that will or is likely to cause an outage or any type of power disruption to COVAD equipment located in the BELL ATLANTIC facility. At all times prior to the date on which remote access is provided to COVAD pursuant to subsection 2.2.21.3.3 above, BELL

ATLANTIC agrees to provide promptly to COVAD telephone notification of the occurrence of all power failures or environmental conditions affecting any Collocation Premises within which COVAD maintains Collocated Space, which power failures or environmental conditions have the potential, in the reasonable determination of BELL ATLANTIC, to adversely affect the operation of, or access to, COVAD's equipment located in Collocated Space maintained by COVAD within such Collocation Premises. Notwithstanding the provisions of Section 17 of the General Terms and Conditions of this Agreement, notice under this Section 2.2.21.3.7 may be either written, oral or provided through electronic interface and will be provided to those persons designated pursuant to Section 2.2.20.5.

- 2.2.22 Intentionally Omitted.
- 2.2.23 BELL ATLANTIC will design and construct, at COVAD's expense, a cage or room to establish a clear division between BELL ATLANTIC's space and COVAD's collocated space.
- 2.2.24 BELL ATLANTIC shall provide collocated space that is in material compliance with all Applicable Laws, including OSHA. BELL ATLANTIC will notify COVAD of any non-compliant condition to the extent such condition is brought to BELL ATLANTIC's attention, and shall promptly remedy such condition to the extent that such condition was caused by any negligent act or failure to act of BELL ATLANTIC.
- 2.2.25 BELL ATLANTIC shall be permitted to conduct inspections at irregular intervals of all or portions of the COVAD's facilities, to determine that occupancies are authorized and are installed and maintained in conformance with the required standards set forth in this Agreement. BELL ATLANTIC will provide COVAD with five (5) days' advance notice of such non-emergency inspections, and COVAD's representatives shall have the right to be present at the time of inspection.
- 2.2.26 After construction of the collocated space and to the extent that

they may be reasonably required to accommodate COVAD's use of the collocated space, COVAD shall be permitted to conduct inspections at irregular intervals of all or portions of the BELL ATLANTIC Local Serving Office or other BELL ATLANTIC location(s) including but not limited to power cable runs, cable vaults, and cable risers used to connect COVAD's Customers or its power to COVAD's facilities. COVAD will provide BELL ATLANTIC with five (5) day's advance written notice of such inspections, and BELL ATLANTIC's representatives shall have the right to be present at the time of inspection.

2.2.27 Subject to the satisfaction by COVAD of the conditions contained elsewhere herein, BELL ATLANTIC grants COVAD a license to occupy:

- (i) the collocated space;
- (ii) space within the cable riser, cable rack support structure and cable vault designated by BELL ATLANTIC; and
- (iii) space within the access conduit within the riser in the central office from the BELL ATLANTIC cable vault to the COVAD cage.

The foregoing space requirements are more fully described in the applicable Collocation Schedules, if any, the form of which is attached hereto, made a part hereof and marked Appendix A, as well as any such Collocation Schedules which are later agreed to by the parties.

2.2.28 In connection with the collocated space made available hereunder, BELL ATLANTIC will provide 110V A.C. power for convenience outlets, lighting for frames, and "stumble" lighting in the collocated space (as per Bellcore NEBS document TREOP000063). BELL ATLANTIC will also provide 48 volt battery-backed D.C. power for COVAD's equipment. The charges for these items are listed in each Collocation Schedule. Notwithstanding BELL ATLANTIC's obligation herein to provide "stumble" lighting only, COVAD shall be entitled to receive from BELL ATLANTIC the same level of any greater illumination which BELL ATLANTIC may provide to any other Telecommunications Carrier at the Collocation Premises.

- 2.2.29 In the event COVAD occupies more than one collocated space location within the same BELL ATLANTIC Collocation Premises, COVAD will be permitted to interconnect its equipment contained in such collocated spaces. At these BELL ATLANTIC Collocation Premises, for noncontiguous collocated spaces BELL ATLANTIC will provide to COVAD, at COVAD's expense, (i) cable racking between COVAD's collocated space locations using BELL ATLANTIC designated supporting structures, and (ii) connecting cable installation. BELL ATLANTIC will provide the most direct collocated space connection route possible. For contiguous collocated spaces, COVAD will be responsible for supplying and installing the cabling and cable racking between such COVAD collocated space locations using BELL ATLANTIC designated support structures.
- 2.2.30 COVAD shall be permitted to place in collocated space storage cabinets, cross connect frames and work surfaces (e.g., tables). However, in no event shall COVAD place flammable or hazardous materials in the collocation space. To help ensure the availability of sufficient space for other interconnectors, the storage cabinets and work surfaces shall not take up more than 50% of collocated space and shall meet BELL ATLANTIC central office environmental standards (NIP 74165 BELL ATLANTIC Central Office Environmental Requirements), in effect at the time of COVAD's equipment installation and as they may be modified from time to time, copies of which will be provided (including all updates), to COVAD at cost. COVAD shall be provided with a reasonable period of time after receipt of NIP 74165 updates to comply with their terms. COVAD will provide, install and maintain in collocated space any repeaters which may be necessary as a result of the physical distance between collocated space and the office premises terminations of the BELL ATLANTIC network. BELL ATLANTIC will employ the same procedures, aimed at minimizing this distance, as it does in conjunction with its own equipment.
- 2.2.31 All equipment permitted to be placed within COVAD's Collocated Space shall comply with Bellcore Network Engineering Building System (NEBS) General Equipment Requirements (TREOP000063), the National Electric Code and Bellcore safety standards, including GR-1089, in effect at the time of installation

and as they may be modified from time to time. COVAD shall be provided with a reasonable period of time after any update of said standards, to comply with its modified terms.

2.2.32 COVAD's equipment and installation of COVAD's equipment shall comply with the BELL ATLANTIC Information Standards for Central Office Installation and Removal Procedures (NIP74160) and with BELL ATLANTIC Workmanship Requirement Profile, and BELL ATLANTIC's central office engineering environmental standards (NIP74165), in effect at the time of installation, and as they may be modified from time to time, as they relate to fire, safety, health, environmental, and network safeguards, copies of which will be provided (including all updates), to COVAD at cost. COVAD shall have the right to exceed the standards. COVAD shall be provided with a reasonable period of time after receipt of any NIP74160, 74165 updates, to comply with their terms.

2.2.33 COVAD's facilities shall be placed, maintained, relocated or removed in accordance with the applicable requirements and specifications of the current editions of the National Electrical Code (NEC), the National Electrical Safety Code (NESC) and rules and regulations of the Occupational Safety and Health Act (OSHA), and any governing authority having jurisdiction in effect at the time of installation and as they may be modified from time to time. All COVAD entrance facilities and splices shall comply with Bellcore Generic Specification for Optical Fiber and Optical Fiber cable (TRTSY00020), Cable Placing Handbook (NX620020912NY), Cable Splicing Handbook (NX620020911NY), Cable Maintenance Handbook (NX620020913NY), and General Information Tools and Safety (NY620020910NY) in effect at the time of installation, and as they may be modified from time to time, as they relate to fire, safety, health, environmental safeguards or interference with BELL ATLANTIC services or facilities, copies of BELL ATLANTIC documents will be provided (including all updates), to COVAD at cost. The COVAD collocated space equipment shall also comply with BELL ATLANTIC's central office engineering, environmental and transmission standards in effect at the time of installation as they may be modified from time to time, as they relate to fire, safety, health, environmental safeguards, or interference with BELL ATLANTIC services or facilities. Where a difference in specification may exist, the more stringent shall apply. COVAD's facilities shall

not physically, electronically, or inductively interfere with BELL ATLANTIC's or other interconnectors' or tenants' facilities. COVAD shall have the right to exceed any of the foregoing standards or technical requirements. With respect to the foregoing BELL ATLANTIC standards documents which have been updated and provided to COVAD, COVAD shall be provided with a reasonable period of time after receipt of such updates to comply with their modified terms. Insofar as the NEC, NESC and OSHA requirements are concerned, COVAD shall be provided with a reasonable period of time after updates to those requirements, to comply with their modified terms.

- 2.2.34 While many of the standards and technical requirements for COVAD's cable, equipment and facilities are set forth in subsection 2.2.33 above, BELL ATLANTIC reserves the right to reasonably specify the type of cable, equipment and construction standards reasonably required in situations not otherwise covered in this Agreement. In such cases, BELL ATLANTIC will furnish to COVAD, promptly when it becomes available, written material which will specify and explain the required construction.
- 2.2.35 All work for which COVAD is responsible shall be performed by BELL ATLANTIC authorized vendors. Such authorization will not be unreasonably withheld or delayed.
- 2.2.36 BELL ATLANTIC reserves the right to prohibit all equipment and facilities, other than cable, from its entrance manholes. No splicing will be permitted in Manhole "O". COVAD shall provide a length of underground fiber optic cable in Manhole "O" of sufficient length to be pulled through the BELL ATLANTIC central office premises conduit and into the office premises cable vault splice location. COVAD is responsible for placement of the cable facility within Manhole "O". COVAD is responsible for the maintenance of the cable(s). BELL ATLANTIC is responsible for maintaining its manholes.
- 2.2.37 COVAD is responsible for installing COVAD provided feeder cable in the conduit space. BELL ATLANTIC may provide shared conduit with dedicated inner duct. COVAD will not be permitted to reserve space in the BELL ATLANTIC office premises conduit. If new conduit is required, BELL ATLANTIC will negotiate with COVAD to

determine a further agreement to deal with the specific location.

- 2.2.38** COVAD is responsible for installing and maintaining a splice where its feeder cable meets its fire retardant inside riser cable within the BELL ATLANTIC office premises cable vault or designated splicing chamber; the splice in the office premises cable vault shall be a mechanical splice, to avoid safety hazards; no fusion splicing will be permitted. BELL ATLANTIC will provide space and racking for the placement of an approved secured fire retardant splice enclosure. COVAD shall tag all entrance facilities to indicate ownership.

To avoid unnecessary reinforcements or arrangements, COVAD agrees to size the facilities to meet three (3) year forecasted demand, where feasible. COVAD will be accompanied by qualified BELL ATLANTIC representatives in all manhole and cable vault locations on a time and materials basis, as such hourly charges are specified in applicable tariffs, including but not limited to P.S.C. No. 900 and the Collocation Schedule(s). COVAD will have access to all manhole and cable vault locations as required for installation and emergency maintenance repairs.

- 2.2.39** COVAD is responsible for placing its fire retardant riser cable from the BELL ATLANTIC office premises vault to the collocated space. COVAD is responsible for providing fire retardant riser cables which shall comply with BELL ATLANTIC practices and safety requirements for office premises cabling (TRNWT000409 and National Electrical Code) in effect at the time of installation and as they may be modified from time to time, as they relate to fire, safety, health and environmental safeguards, copies of which will be provided (including all updates), to COVAD at cost. COVAD shall be provided with a reasonable period of time after receipt of updates of the foregoing requirements documents, to comply with their modified terms. Within ten (10) days after BELL ATLANTIC's confirmation of collocated space availability, BELL ATLANTIC and COVAD will jointly determine the length of fire retardant cable needed to reach from the splice in the cable vault to COVAD's collocated space. Special arrangements will be agreed upon to meet unusual conditions such as midspan splicing requirements. BELL ATLANTIC will allocate common riser ducts and common racking where possible. Added or special racking rearrangements

requested by COVAD will result in time and materials charges as such hourly charges are specified in applicable tariffs, including but not limited to P.S.C. No. 900 Tariff, and Collocation Schedule(s). COVAD is responsible for all maintenance of its communication cables. Where diverse cable vaults permit diverse entrances into the BELL ATLANTIC office premises by COVAD's cable, diverse, separated physically by a minimum of six (6) feet, and where space in such diverse entrances may be available, cable riser ducts and/or cable racking shall be provided by BELL ATLANTIC.

- 2.2.40 Upon COVAD's request and where technically feasible and where space permits, BELL ATLANTIC shall provide two (2) points of entry to the Collocation Premises.
- 2.2.41 BELL ATLANTIC is also responsible for providing collocated space in accordance with the terms in subsection 2.4 below. COVAD will be responsible for accepting delivery, installation and maintenance of its equipment within the collocated space.
- 2.2.42 COVAD may not construct substantial improvements or make material alterations or repairs to the collocated space without the prior written approval of BELL ATLANTIC, which approval BELL ATLANTIC will not unreasonably withhold or delay. Nothing herein, however, shall prevent COVAD from making minor improvements and/or non-material alterations or repairs to the collocated space without notice to and approval from BELL ATLANTIC.
- 2.2.43 BELL ATLANTIC will designate point(s) of termination on cross connect frames or similar devices as the point(s) of physical demarcation between COVAD's facilities and BELL ATLANTIC's facilities.
- 2.2.44 The cross connect frames where the point of termination(s) is located will be provided at or near the collocated space. COVAD will provide and be responsible for installing and maintaining the connection cabling and associated cross connections between the collocated space and the point of termination. BELL ATLANTIC will provide and be responsible for installing and maintaining all facilities on the BELL ATLANTIC side of the point of termination. COVAD will pay a Maintenance of Service Charge, as specified in BELL ATLANTIC's applicable tariffs, including but not limited to

P.S.C. No. 900 Tariff, whenever BELL ATLANTIC personnel are required to identify a trouble as being on COVAD's side of the point of termination, e.g., in the connection cabling or associated cross connections.

2.2.45 If at any time BELL ATLANTIC determines that either COVAD's equipment or its installation does not substantially meet the requirements outlined in this Agreement, COVAD will be responsible for the costs associated with the removal of equipment or modification of the equipment or installation to render it compliant. If COVAD fails to correct any noncompliance with these standards within sixty (60) days' written notice to COVAD, BELL ATLANTIC may have the equipment removed or the condition corrected at COVAD's expense. If, during the installation phase, BELL ATLANTIC reasonably determines any COVAD activities or equipment are unsafe or in violation of any applicable environmental or other laws or regulations specified in this Agreement, BELL ATLANTIC has the right to immediately stop the work or place it on hold. However, when such conditions pose an immediate threat to the safety of BELL ATLANTIC's employees, interfere with the performance of BELL ATLANTIC's service obligations, or pose an immediate threat to the physical integrity of the conduit system or the cable facilities of BELL ATLANTIC, BELL ATLANTIC may perform such work and/or take such reasonable action that BELL ATLANTIC deems necessary without prior notice to COVAD. The cost of said work and/or actions shall be borne by COVAD.

2.3 Technical References BELL ATLANTIC and COVAD shall comply with the following standards:

- 2.3.1** Institute of Electrical and Electronics Engineers (IEEE) Standard 383, IEEE Standard for Type Test of Class 1 E Electric Cables, Field Splices, and Connections for Nuclear Power Generating Stations.
- 2.3.2** National Electrical Code (NEC) use latest issue.
- 2.3.3** TANPL000286, NEBS Generic Engineering Requirements for System Assembly and Cable Distribution, Issue 2, (Bellcore, January 1989).
- 2.3.4** TREOP000063 Network Equipment-Building System (NEBS) Generic

Equipment Requirements, Issue 3, March 1988.

- 2.3.5 TREOP000151, Generic Requirements for 24, 48, 130, and 140 Volt Central Office Power Plant Rectifiers, Issue 1, (Bellcore, May 1985).
- 2.3.6 TREOP000232, Generic Requirements for Lead-Acid Storage Batteries, Issue 1 (Bellcore, June 1985).
- 2.3.7 TRNWT000154, Generic Requirements for 24, 48, 130, and 140 Volt Central Office Power Plant Control and Distribution Equipment, Issue 2, (Bellcore, January 1992).
- 2.3.8 TRNWT000295, Isolated Ground Planes: Definition and Application to Telephone Central Offices, Issue 2, (Bellcore, July 1992).
- 2.3.9 TRNWT000840, Supplier Support Generic Requirements (SSGR), (A Module of LSSGR, FRNWT000064), Issue 1, (Bellcore, December 1991).
- 2.3.10 TRNWT001275 Central Office Environment Installations/Removal Generic Requirements, Issue 1, January 1993.
- 2.3.11 Underwriters' Laboratories Standard, UL 94.

2.4 Other Requirements

2.4.1 Intentionally Omitted

- 2.4.2 During the Term, as the same may be extended, COVAD may occupy the collocated space set forth in the Collocation Schedule(s). Occupancy for all space will be granted upon completion of the design and construction work including "cut down" of BELL ATLANTIC cabling at the point of termination based on the requested interconnections identified by COVAD in its request for collocation. In the event that BELL ATLANTIC is delayed in providing occupancy to COVAD for any reason other than the acts or omissions of COVAD which proximately give rise to the delay, COVAD shall not be obliged to pay the occupancy/power fees for such collocated space under this Agreement until the date BELL ATLANTIC provides occupancy/power to COVAD.

- 2.4.3 BELL ATLANTIC shall have the right to terminate a Collocation Schedule at any time with respect to collocated space area of the BELL ATLANTIC office premises which becomes the subject of a taking by eminent authority having such power. BELL ATLANTIC shall notify COVAD of such termination immediately after it receives notice of the taking, and shall also identify the schedule by which COVAD shall proceed to have COVAD's equipment or property removed from the collocated space and associated cable and conduit spaces. COVAD shall have no claim against BELL ATLANTIC for any relocation expenses, any part of any award that may be made for such taking or value of any unexpired initial Collocation Schedule term or renewal periods that results from a termination by BELL ATLANTIC under this provision, or any loss of business from full or partial interruption or interference due to any such termination. Nothing herein shall be construed as preventing COVAD from making its own claim against the eminent authority ordering the taking of the collocated space area of the BELL ATLANTIC office premises for COVAD's relocation expenses.
- 2.4.4 COVAD may, without cause and for its convenience, terminate a Collocation Schedule as to any collocated space or portion thereof (in 100 sq. ft. decrements), cable and conduit space and D.C. power described in Appendix A by giving sixty (60) days' prior written notice to BELL ATLANTIC. However, any remaining collocated space licensed under this Agreement may not be less than 100 square feet. COVAD is responsible for the costs of any such partial termination (e.g., reconstructing the collocated space).
- 2.4.5 COVAD shall have the option to renew its license to occupy any of its collocated space and associated cable and conduit space for the period(s) of time and on the terms and conditions to be mutually agreed upon by COVAD and BELL ATLANTIC (the "Renewal Period"). The Renewal Period will become the new term of the Collocation Schedule at the time of execution of an amendment thereto extending the period of occupancy. COVAD has the option to further renew at the end of each Renewal Period unless found to be in material breach of the terms and conditions of the Collocation Schedule and this Agreement. If agreement on renewal is not reached prior to the termination date, and the collocated space is needed for other interconnectors or BELL ATLANTIC, BELL ATLANTIC will so inform

COVAD of that need and will provide COVAD with up to a three (3) months grace period in which to renew its license. The rates and fees applicable for that three (3) month period will be those set forth in this Agreement or, if there shall be an applicable tariff rate, in the applicable tariff rates, including but not limited to P.S.C. No. 900 Tariff.

If COVAD fails to renew before the expiration of the Collocation Schedule period of occupancy and if the collocated space is not needed by BELL ATLANTIC or other interconnectors, BELL ATLANTIC will permit COVAD to continue to occupy the collocated space on a month-to-month basis for a maximum of twelve (12) months in order to negotiate renewal terms and conditions. The rates applicable to this month-to-month license occupancy by COVAD shall be those set forth in this Agreement or, if there shall be an applicable tariff rate, in the applicable tariff rates, including but not limited to P.S.C. No. 900 Tariff rates. COVAD's option to renew its license to occupy the collocated space shall be contingent on the election by BELL ATLANTIC to continue to own or lease the premises in which the collocated space is located for the duration of the Renewal Period(s), with such election to be exercised at the sole discretion of BELL ATLANTIC. In no event may any period of occupancy (including any by COVAD Renewal Period) of any collocated space and associated cable and conduit space extend beyond the Term (as the Term may be extended by the Parties).

2.4.6 Intentionally Omitted

2.4.7 COVAD shall provide BELL ATLANTIC, together with a completed Application for Collocation as described in subsection 2.2.20 above, the applicable tariff application fee for each collocated space requested. This amount will be used to cover the cost of the preconstruction survey and other associated BELL ATLANTIC activities.

2.4.8 BELL ATLANTIC will process applications for collocated space occupancy on a first-come, first-served basis as determined through the receipt of the application fee in accordance with the provisions of subsection 2.4.7 above.

2.4.9 After receipt of COVAD's Application for Collocation and appropriate

application fee(s) and upon request by COVAD, BELL ATLANTIC will promptly make available to COVAD, at cost, any BELL ATLANTIC-specific technical specifications and BELL ATLANTIC office premises security rules and regulations documentation which may be listed in this Part III. Updates to this documentation will be furnished to COVAD when they become available. BELL ATLANTIC and COVAD agree to work cooperatively to develop an equipment layout (based on equipment dimension data furnished by COVAD) that complies with the specifications described in subsection 2.2.21.3 herein to be placed within collocated space, in order to minimize space requirements in a safe and economical manner. BELL ATLANTIC also agrees that, within a reasonable period of time after BELL ATLANTIC's acceptance of COVAD's collocation request, BELL ATLANTIC and COVAD will conduct a walk-through of the planned COVAD cable path. BELL ATLANTIC shall provide COVAD with sufficient information and access to the cable path so that COVAD may itself determine the length of cable required.

2.4.10 BELL ATLANTIC will conduct a preconstruction survey for each COVAD request for collocated space to determine the availability of such spaces to accommodate COVAD's facilities.

2.4.11 If COVAD shall at any point during cage construction withdraw its request for collocated space or shall terminate this Agreement, it shall be liable to BELL ATLANTIC for any and all construction costs incurred as of the date of such withdrawal or termination.

2.4.12 Intentionally Omitted

2.4.13 In the event BELL ATLANTIC determines that BELL ATLANTIC's or any other entity's cable facilities in conduit cable spaces or BELL ATLANTIC's office premises equipment need rearrangement to accommodate the facilities of COVAD identified in its Application for Collocation, BELL ATLANTIC will advise COVAD of such proposed rearrangement, the estimated costs therefor and, upon COVAD's agreement, include said reasonable costs in the design and construction work charges. Best efforts will be made to minimize the cost of such rearrangements.

COVAD agrees to meet with BELL ATLANTIC on an as-needed basis to review the design and construction work plans and schedules for the collocated space, and installation of COVAD's equipment within its collocated space.

- 2.4.14** Unless otherwise agreed to by the Parties in writing, the COVAD collocated space floor plan layout agreed to by COVAD and BELL ATLANTIC shall not be changed substantially after a no-change freeze date which shall be mutually agreed to by the Parties.
- 2.4.15** Prior to beginning installation work or occupancy, the Parties shall sign the Design and Construction Work Completion Notice (Appendix E) indicating acceptance of design and construction work. BELL ATLANTIC will render a final bill to reconcile the design and construction work estimate with actual costs when those changes are known. Payment of the undisputed charges is due within forty-five (45) days of receipt of the bill.
- 2.4.16** Before beginning any delivery, installation, replacement or removal work for equipment and/or facilities located within COVAD's collocated space, COVAD shall obtain BELL ATLANTIC's written approval of COVAD's proposed scheduling of the work in order to coordinate use of temporary areas and other building facilities. BELL ATLANTIC may request additional information before granting approval, and may require reasonable scheduling changes. Such approval will not be unreasonably withheld or delayed.
- 2.4.17** If BELL ATLANTIC requires that there be any acceptance testing of COVAD's equipment installed in the collocated space, then any and all applicable testing procedures shall be mutually agreed to by the Parties and set forth in the applicable Collocation Schedule.
- 2.4.18** COVAD shall have the right to use a portion of the BELL ATLANTIC office premises and loading areas on a temporary basis during COVAD's equipment installation work in the collocated space. COVAD is responsible for protecting BELL ATLANTIC's equipment and office premises flooring within the staging area and along the staging route. COVAD will store equipment and materials within collocated space when work is not in progress (e.g., overnight). No

storing of equipment and materials overnight will be permitted in the staging area(s). The temporary staging area will be vacated by COVAD and delivered to BELL ATLANTIC in broom clean condition, upon completion of COVAD's installation work, ordinary wear and tear excepted.

- 2.4.19 If BELL ATLANTIC sells or leases the Collocation Premises with collocated space or any portion thereof to a third party, BELL ATLANTIC shall require that third party to comply fully with the terms and conditions of this Agreement as it relates to the provision of collocation for a minimum period of one (1) year.
- 2.4.20 Within thirty (30) days of the receipt of the invoice therefor, COVAD shall pay all reasonable charges incurred by BELL ATLANTIC for collocation, which charges shall be based on the applicable rates set forth in P.S.C. No. 900 Tariff. Compensation to BELL ATLANTIC for collocation charges shall also include (i) any special charges required as a result of the type of equipment COVAD wishes to collocate (including any equipment referred to in Section 2.2.4) provided that COVAD is advised of these charges prior to their incurrence, and (ii) any equipment required by BELL ATLANTIC to be installed in order to prevent safety and quality problems (provided such preventative measures are not applied in an unreasonable and discriminatory fashion). Failure to make such payment after notice and opportunity to cure within fifteen (15) days after receipt of said notice, constitutes a material breach of this Agreement.
- 2.4.21 Fees are exclusive of any applicable telecommunications, utility or similar taxes. Those taxes will be applied, where applicable. COVAD agrees to pay or reimburse BELL ATLANTIC for any applicable taxes that are levied based on the transactions hereunder. BELL ATLANTIC agrees to provide COVAD with reasonable documentation to support billed amounts for taxes within sixty (60) calendar days after receipt of COVAD's written request.
- 2.4.22 The fees set forth in Appendix A are fixed for the term of the Collocation Schedule. Fees for any Renewal Period shall be negotiated and mutually agreed to by the Parties.

2.4.23 The fees for design and construction work shall be paid by COVAD in accordance with the following milestones:

<u>Payment</u>	<u>Milestone/Event</u>
FIRST INSTALLMENT (50% of total estimate)	First Installment will be paid at the time COVAD accepts BELL ATLANTIC's proposal pursuant to Section 2.2.20.1 of this Part III.
FINAL BILL (Reconciliation of Fees)	Final Bill will be rendered based upon actual costs and charges and is payable within forty-five (45) days of receipt of the bill, but no sooner than BELL ATLANTIC's completion of design and construction work.

This payment schedule may be adjusted pursuant to section 17A of the General Terms and Conditions of this Agreement.

2.4.24 COVAD shall reimburse BELL ATLANTIC for all repair or restoration costs to BELL ATLANTIC's tangible office premises associated with damage or destruction proximately caused by COVAD's personnel, COVAD's agents, or COVAD's suppliers/contractors or COVAD's visitors (other than BELL ATLANTIC).

2.4.25 COVAD shall, at its sole cost and expense procure, maintain, pay for and keep in force insurance as specified in subsections 2.4.25.1 through 2.4.25.5 below, and underwritten by insurance companies licensed to do business in the State of New York having a BEST Insurance rating of at least AA-12. BELL ATLANTIC shall be named as an additional insured on COVAD's insurance certificate. BELL ATLANTIC shall also be named as a loss payee (as its interests may appear) on all applicable insurance policies required hereunder. COVAD's agreement to provide the certificate of insurance shall neither modify nor expand the liability limitations in this Agreement, nor shall such agreement to insure be construed as a pre-indemnification

for any BELL ATLANTIC claim or demand.

2.4.25.1 Comprehensive general liability coverage on an occurrence basis in an amount of \$2 million combined single limit for bodily injury and property damage, with a policy aggregate of \$2 million. Said coverage shall include the contractual, independent contractors products/completed operations, broad form property and personal injury endorsements;

2.4.25.2 Umbrella/Excess Liability coverage in an amount of \$5 million excess of coverage specified in subsection 2.4.25.1 above;

2.4.25.3 All Risk Property coverage on a full replacement cost basis insuring all of COVAD's real and personal property situated on or within BELL ATLANTIC location(s);

2.4.25.4 Statutory Workers Compensation coverage; and

2.4.25.5 Employers Liability coverage in an amount of \$2 million.

2.4.26 All insurance shall be in effect on or before the occupancy date and shall remain in force as long as COVAD's facilities remain within any collocated space governed by this Agreement. If COVAD fails to maintain the coverage required by this Agreement, BELL ATLANTIC may pay the premiums thereon and shall be reimbursed by COVAD for said premiums which have been paid. Any increase in insurance limits requested by BELL ATLANTIC during a Renewal Period shall be subject to negotiations by the Parties.

2.4.27 COVAD shall submit its evidence of insurance prior to the commencement of the work called for in the Agreement. COVAD shall arrange for BELL ATLANTIC to receive thirty (30) days advance notice of cancellation from COVAD's insurance company. Notice of any cancellation should be forwarded to New York Telephone, 1095 Avenue of the Americas, Room 3925, New York, New York 10036, Attention: Risk Management.

2.4.28 COVAD shall also conform to the recommendation(s) made by BELL

ATLANTIC's fire insurance company which BELL ATLANTIC has already agreed to or to such recommendations it shall hereafter agree to. Any such recommendations shall be immediately furnished to COVAD in writing, with any and all written updates promptly provided by BELL ATLANTIC to COVAD from time to time. COVAD shall be given a reasonable amount of time to comply with the foregoing recommendations.

- 2.4.29 Failure to comply with the provisions of subsections 2.4.25 through 2.4.28 above after written notice by BELL ATLANTIC to COVAD and an opportunity to cure said default within thirty (30) days after receipt of said notice, will be deemed a material breach of this Agreement.
- 2.4.30 Any mechanic's lien filed against the BELL ATLANTIC office premises or the real property of which such office premises are a part for work claimed to have been done for, or materials claimed to have been furnished to COVAD, shall be discharged of record by COVAD within thirty (30) days thereafter, at COVAD's expense, by payment, deposit, bond or court order.
- 2.4.31 BELL ATLANTIC may require COVAD to post a form of reasonable performance bond or security deposit if BELL ATLANTIC determines, in its reasonable and sole judgment, that there is a credit risk associated with COVAD's ability to pay design and construction work/occupancy and power fees hereunder. If COVAD shall fail to pay any sum demanded by BELL ATLANTIC as due under the provisions of this Part III, BELL ATLANTIC shall have the right, without prior notice to COVAD forthwith, to apply any or all amounts on deposit with it for collocation to payment of the sum due, whether or not BELL ATLANTIC exercises or has exercised any option it may have to terminate the applicable collocation arrangement. If any such amounts are applied to payment of sums due to BELL ATLANTIC under this Part III, COVAD shall restore to its deposit the amounts so applied within thirty (30) days after notice to COVAD of such application.
- 2.4.32 The initial license granted to COVAD for collocated space is subject to a minimum requirement of 100 square feet and a maximum of 400 square feet per collocation cage. Additional space will be provided on an as-needed basis where feasible if COVAD's existing space is being

"efficiently used" as defined in subsections 2.4.34 and 2.4.35 below. COVAD can request additional space in increments of 100 square feet, unless otherwise agreed to by BELL ATLANTIC, by completing a new Application for Collocation following the procedures described above.

2.4.33 In connection with an existing collocated space license for a minimum of 100 square feet, COVAD has the option to reserve either 100 square feet, 200 square feet, or 300 square feet of space in the same BELL ATLANTIC office premises which will be partitioned at some future date ("Reserved Space") for a maximum total of 400 square feet per collocation cage. BELL ATLANTIC will make best efforts to assign the Reserved Space so that it is contiguous with the collocated space. Reservation of space pertains only to floor space. COVAD may not reserve cable or conduit spaces. BELL ATLANTIC will reserve the space until such time as BELL ATLANTIC requires the Reserved Space.

2.4.34 For purposes of this Agreement, "efficiently used" shall mean that substantially all of the floor space (no more than 50% used for storage cabinets and work surfaces in accordance with subsection 2.2.32 above) is taken up by COVAD's equipment, placed no greater than 20% above the minimum distances permitted by NEBS.

2.4.35 If collocated space is needed to accommodate other interconnectors or BELL ATLANTIC's service to its end-user Customers, BELL ATLANTIC will take back from COVAD collocated space that is not being "efficiently used" (except for 100 square feet of such space), upon ninety (90) days advance written notice to COVAD and any opportunity for COVAD, during this notice period to place equipment in the collocated space so that it is "efficiently used" and not subject to being taken back by BELL ATLANTIC. However, COVAD shall have placed some equipment within that 100 square feet that it interconnected to BELL ATLANTIC's network.

2.4.36 COVAD will supply BELL ATLANTIC with a list of its employees or approved vendors who require access. The list will include social security numbers of all such individuals. All individuals shall be U.S. citizens.

- 2.4.37 BELL ATLANTIC will issue non-employee photo identification for each COVAD employee/vendor listed in accordance with subsection 2.4.36 above. These cards will have a uniquely colored background. BELL ATLANTIC will issue access cards to each listed employee/vendor where access card systems are available. This card will permit access to the location of COVAD's collocated space. COVAD is responsible for returning cards of its terminated employees/vendors. All cards shall be returned upon termination of the applicable Collocation Schedule.
- 2.4.38 Where card access is not available, a BELL ATLANTIC escort may be required.
- 2.4.39 COVAD employee/vendor(s) shall display identification cards at all times.
- 2.4.40 BELL ATLANTIC will provide, on a time and materials basis, card access to COVAD's collocated space where requested by COVAD and where access systems are available. Such time and materials charges are set forth in Appendix A.
- 2.4.41 Where COVAD provides the security device for its collocated space, COVAD will provide access for BELL ATLANTIC in the event of an emergency and to perform its required housekeeping and equipment inspection activities. Any housekeeping and equipment inspection activities shall be conducted in the presence of COVAD's representatives.
- 2.4.42 During the installation phase, or for subsequent maintenance, COVAD or its approved vendor will have access to its collocated space and any room or area required by them to necessitate the installation. COVAD may be escorted in areas outside its collocated space by qualified BELL ATLANTIC employees for these occasions.
- 2.4.43 In the event of work stoppages, separate entrances will be established for COVAD, where possible. This will assure that one Party's work stoppage does not impinge upon the other Party's normal work

operations. Failure to provide such separate entrances shall not render BELL ATLANTIC liable to COVAD for any claim for damages.

- 2.4.44 Upon termination of COVAD's license for its collocated space or any 100 sq. ft. portion thereof, COVAD shall remove its equipment from that space within sixty (60) days. Upon removal by COVAD of all its equipment from the collocated space or portion thereof, COVAD shall restore that collocated space to a broom clean condition, normal wear and tear and removal of the cage excepted. Due to physical and technical constraints, removal of cable is at BELL ATLANTIC's option.
- 2.4.45 Should COVAD wish to move equipment from one collocated space to another, COVAD will be responsible for removing and transporting its equipment to the new site and installing it.
- 2.4.46 Should BELL ATLANTIC need to install additional facilities in any conduit system in which COVAD occupies conduit space for the purpose of meeting its own service requirements or for providing for other interconnectors, BELL ATLANTIC will, after notifying COVAD of the additional occupancy, use its best efforts to avoid rearrangement of COVAD's facilities, however, if such rearrangement cannot be so avoided, BELL ATLANTIC shall rearrange COVAD's facilities in the conduit system as reasonably determined by BELL ATLANTIC so that the additional facilities of BELL ATLANTIC, or other interconnectors, may also be accommodated.
- 2.4.47 In an emergency, BELL ATLANTIC will use reasonable efforts to notify COVAD, but nevertheless may rearrange COVAD's facilities occupying a conduit, manhole, cable vault, riser system or cable support structure without prior notification. Such rearrangement will be at COVAD's expense to the extent that such emergency is caused by any act or omission on the part of COVAD, its employees, agents, or vendors. Otherwise BELL ATLANTIC, not COVAD, will be liable for the rearrangement expense.
- 2.4.48 Where COVAD intends to modify, move, replace or add to equipment or facilities within or about the collocated space after the first installation is complete and requires special consideration (e.g., use of freight elevators, loading dock, staging area, etc.), COVAD shall

request and receive written consent from BELL ATLANTIC. Such consent will not be unreasonably withheld or delayed.

- 2.4.49** COVAD will provide emergency access to its collocated space at all times to allow BELL ATLANTIC to react to emergencies, to maintain the space (where applicable) and to ensure compliance with OSHA/BELL ATLANTIC regulations and standards related to fire, safety, health, and environmental safeguards.
- 2.4.50** If the collocated space, cable space, or conduit space or any part thereof shall be damaged by fire or other casualty, COVAD shall give prompt notice thereof to BELL ATLANTIC and the applicable Collocation Schedule shall continue in full force and effect except as hereinafter set forth.
- 2.4.51** If the collocated space, cable space or conduit space is partially damaged or rendered partially unusable by fire or other casualty not caused by COVAD, the damages thereto shall be repaired by and at the expense of BELL ATLANTIC. The occupancy/power fees, until such repair shall be substantially completed, shall be apportioned from the day following the casualty according to the part of the collocated space, cable space or conduit space which is usable.
- 2.4.52** If the collocated space, cable space or conduit space is totally damaged or rendered substantially unusable by fire or other casualty not caused by COVAD, then the occupancy/power fees shall be proportionately paid up to the time of the casualty and thenceforth shall cease until the date when the collocated space, cable space or conduit space shall have been repaired and restored by BELL ATLANTIC, subject to BELL ATLANTIC's right to elect not to restore the same as hereinafter provided.
- 2.4.53** If the collocated space, cable space, or conduit space is rendered wholly unusable through no fault of COVAD, or (whether or not the demised premises are damaged in whole or in part) if the building shall be so damaged that BELL ATLANTIC shall decide to demolish it or to rebuild it, then, in any of such events, either Party may elect to terminate the applicable Collocation Schedule by written notice to the other given within ninety (90) days after such fire or casualty specifying

a date for the expiration of the said Collocation Schedule, which date shall not be more than sixty (60) days after the giving of such notice, and upon the date specified in such notice the period of occupancy/Renewal Period of the Collocation Schedule shall expire as fully and completely as if such date were the date set forth above for the termination of said Collocation Schedule and COVAD shall quit, surrender and vacate the premises without prejudice however to each Party's rights and remedies against the other under the Agreement provisions in effect prior to such termination, and any occupancy/power fees owing shall be paid up to such date and any payments of license fees made by COVAD which were on account of any period subsequent to such date shall be returned to COVAD. Unless either party shall serve a termination notice as provided for herein, BELL ATLANTIC shall make the repairs and restorations under the conditions of subsections 2.4.51 and 2.4.52 hereof, with all reasonable expedition subject to delays due to adjustment of insurance claims, labor troubles and causes beyond BELL ATLANTIC's reasonable control. After any such casualty, COVAD shall cooperate with BELL ATLANTIC's restoration by removing from the collocated space as promptly as reasonably possible, all of COVAD's salvageable inventory and movable equipment, furniture and other property. COVAD's liability for occupancy/power fees shall resume upon occupancy by COVAD or thirty (30) days after written notice from BELL ATLANTIC that the collocation space is restored.

- 2.4.54 COVAD's employees and vendors with access to BELL ATLANTIC's servicing wire center(s) shall at all times adhere to the rules of conduct established by BELL ATLANTIC for the servicing wire center(s) and BELL ATLANTIC's personnel and vendors, copies of which shall be provided to COVAD within a reasonable period of time following receipt of COVAD's request therefor.

BELL ATLANTIC reserves the right to make changes to such procedures and rules to preserve the integrity and operation of BELL ATLANTIC's network and facilities or to comply with Applicable Laws. BELL ATLANTIC shall provide COVAD with thirty (30) days' prior written notice of changes to the procedures and rules to preserve the integrity and operation of the BELL ATLANTIC network and facilities. In addition, since laws and regulations are beyond the control of BELL ATLANTIC, BELL ATLANTIC will provide COVAD with written notice to

comply with Applicable Laws at the same time it notifies its own personnel and vendors.

In the event of a BELL ATLANTIC work stoppage, COVAD's employees, authorized agents and contractors will comply with the emergency operating procedures established by BELL ATLANTIC.

2.4.55 Nothing contained herein shall relieve either Party from liability that may exist as a result of damage from fire or other casualty caused by that Party's negligence or willful misconduct.

2.4.56 Both Parties agree and warrant that, in the performance of this Agreement, neither will discriminate or permit discrimination in employment against any person or group of persons on the grounds of sex, race, age, religion, national origin or handicap in any manner prohibited by the laws of the United States or any state or local government having jurisdiction.

2.4.57 To the extent BELL ATLANTIC is not prohibited under Applicable Laws, BELL ATLANTIC shall permit COVAD to subcontract the construction of physical collocation arrangements with contractors approved by BELL ATLANTIC. To the extent any such subcontracting is permitted hereunder, BELL ATLANTIC shall approve any contractors requested by COVAD based on the same criteria it uses in approving contractors for its own purposes and shall not unreasonably withhold or delay approval of such contractors.

2.5 Virtual Collocation

2.5.1 Service Description

Virtual Collocation provides for the interconnection of BELL ATLANTIC-provided facilities, services and unbundled Network Elements to the network of COVAD, wherein BELL ATLANTIC exercises exclusive physical control over the central office-based equipment/facilities that terminate COVAD's circuits. BELL ATLANTIC dedicates this equipment to the exclusive use of COVAD and provides all the required installation, maintenance, and repair services necessary to assure proper operation of virtually collocated facilities

and equipment. Such work will be performed by BELL ATLANTIC under the direction of COVAD at rates and charges determined on an Individual Case Basis, as specified in Section 2.5.8 below.

Virtual Collocation provides for the interconnection of BELL ATLANTIC-provided facilities, unbundled Network Elements and services to COVAD-provided fiber optic facilities without the physical placement of the COVAD's equipment in a physical collocation arrangement known as a multiplexing node. Virtual Collocation will be provided by means of splicing COVAD's fiber optic cable to a BELL ATLANTIC fiber at a splice area in the central office designated by BELL ATLANTIC.

2.5.2 Virtual Collocation interconnection will be offered via SONET OC3, OC12, and OC48 levels with interconnection to service/elements at DS3, STS-1 and DS1 electrical tributaries interconnected at DSX bays. Also available will be OC3 level optical connections to the fiber distribution frame (FDF), and as options or add-ons to the arrangement, dedicated DS3/DS1 and DS1/DS0 multiplexing arrangements. Such arrangements (the appropriate mix) will be set at the time of original order and installation.

2.5.3 Requests for connections to BELL ATLANTIC services and unbundled Network Elements shall be processed in essentially the same manner as a physically collocated multiplexing node. This service is subject to the availability of space and facilities in each central office where Virtual Collocation is requested.

2.5.4 BELL ATLANTIC is responsible to install and maintain but not test the transmission equipment that will be dedicated to COVAD's use. COVAD has the responsibility to remotely monitor and control its circuits terminating in BELL ATLANTIC's central office, however, COVAD will not enter BELL ATLANTIC's central office under Virtual Collocation arrangements. All physical servicing of the virtually collocated equipment will be performed by BELL ATLANTIC or its agents.

2.5.5 At such time that BELL ATLANTIC's tariff(s) for Virtual Collocation

become effective, the terms and conditions of such tariff(s), as amended from time to time, shall control and govern the provision of Virtual Collocation to COVAD, and the provision of this Agreement governing Virtual Collocation shall be rendered null and void.

2.5.6 SONET (Synchronous Optical Network) arrangements are provided at the OC3, OC12 and OC48 bit rates.

2.5.7 Regulations

2.5.7.1 As an interconnector, COVAD provides fiber-optic facilities through BELL ATLANTIC entrance manholes for connection to BELL ATLANTIC facilities or unbundled Network Elements located in a central office, serving wire center, tandem switching location, remote nodes, as well as all buildings or similar structures owned or leased by BELL ATLANTIC that house BELL ATLANTIC's network facilities.

2.5.7.2 Virtual Collocation will be offered on a first come, first served basis. This service is subject to the availability of space and facilities in each central office where Virtual Collocation is requested. BELL ATLANTIC will require a non-refundable application fee (\$2,500.00) per Virtual Collocation request, per central office or other BELL ATLANTIC location where COVAD wishes to establish Virtual Collocation.

2.5.7.3 COVAD may select transmission equipment from a menu of existing approved equipment. If COVAD specifies equipment not normally used by BELL ATLANTIC, the Bona Fide Request procedure will be followed by COVAD. If BELL ATLANTIC agrees to implement the Request, special arrangements will be made to order the requested equipment. All equipment to be installed in BELL ATLANTIC central offices must comply with the Bellcore Network Equipment Building System (NEBS) Generic Equipment Requirements (Documented in GR-000063-CORE), Electromagnetic Compatibility and Electrical

Safety Generic Criteria for Network Telecommunications Equipment (GR-1089-CORE) and BELL ATLANTIC CO environmental and transmission standards in effect at the time of equipment installation. The equipment must also comply with BELL ATLANTIC Digital Environmental Requirements (NIP 74165), as they relate to fire, safety, health, environmental, and network safeguards. COVAD must provide BELL ATLANTIC documentation demonstrating the above requirements.

- 2.5.7.4 BELL ATLANTIC reserves the right to remove facilities and equipment from its list of approved products if such products, facilities and equipment are determined to be no longer compliant with NEBS standards or Electromagnetic Compatibility and Electrical Safety Generic Criteria for Network Telecommunication Equipment (GR-1089-CORE).
- 2.5.7.5 All COVAD entrance facilities and splices must comply with Bellcore Generic Specification for Optical Fiber and Optical Fiber Cable (TR-TSY-00020), Generic Requirements for Cable Entrance Splice Closures for Copper Cable (TR-NWT-001058), Cable Entrance Facility (CEF) and Building Planning Provisions (BR-760-200-030) and Blue Book Manual of Construction Procedures (SR-TAP-001421) and BELL ATLANTIC Cable Entrance Facility Distribution Services Engineering guidelines as they relate to fire, safety, health, environmental safeguards and interference with BELL ATLANTIC services and facilities.
- 2.5.7.6 BELL ATLANTIC will install, maintain, and repair COVAD-designated equipment under the same intervals and with the same failure rates for the performance of similar functions for comparable BELL ATLANTIC equipment. Costs for training BELL ATLANTIC technicians will be charged to COVAD if COVAD specifies equipment that BELL ATLANTIC does not use in its network.

- 2.5.7.7 BELL ATLANTIC shall designate a BELL ATLANTIC manhole used to enter a BELL ATLANTIC building (known as manhole zero) to which COVAD will run fiber optic cable. COVAD will provide the transmission equipment at its site outside the central office and the associated transport fiber into manhole zero with enough length to reach BELL ATLANTIC designated splice area. COVAD will be responsible to pull the fiber into and through the vault to the splice point and mount the appropriate splice enclosure or shelf which is provided by COVAD as specified by BELL ATLANTIC. This point of splice, which allows outside fiber to plenum type fiber connections, will become the physical point of interconnection to the Virtual Collocation arrangement.
- 2.5.7.8 Cabling from the physical interface point back toward COVAD becomes COVAD's responsibility for all servicing and COVAD maintains full ownership.
- 2.5.7.9 BELL ATLANTIC reserves all rights to terminate, modify or reconfigure the provision of service to COVAD if, in the discretion of BELL ATLANTIC, provision of service to COVAD may in any way interfere with or adversely affect BELL ATLANTIC's network or its ability to service its other Interconnectors. This shall include, but not be limited to, splicing the COVAD-owned portion of the cable to another BELL ATLANTIC fiber optic cable.
- 2.5.7.10 In the event of a transmission failure, the obligation to determine fault location, regardless of whether the fiber span is equipped with optical regeneration equipment, lies with the Party controlling the transmitting end. It is the responsibility of the Party controlling the receiving end to report incoming signal loss to the Party controlling the transmitting end.
- 2.5.7.11 A clear distinction must be made between troubles reported on BELL ATLANTIC services/unbundled Network

Elements connected to the virtually collocated equipment and reports of troubles with the collocated equipment itself. The former can be handled using standard BELL ATLANTIC technicians and processes. The latter will require specially trained technicians familiar with the collocated equipment. The latter will be billed on a time and materials basis.

- 2.5.7.12** If COVAD requires a connection to BELL ATLANTIC optical services or elements, such services and elements will be provided an optical path from the FDF (Fiber Distribution Frame). These services/elements will be cross-connected at the FDF using a transmit and receive fiber. This connection may not be purchased by COVAD without direct association to an offered service or unbundled Network Element, within the terms and conditions of that unbundled Network Element.
- 2.5.7.13** Virtual Collocation is available via SONET or other suitable optical facilities with interconnection to unbundled Network Elements at DS3, STS-1, DS1 electrical tributaries and OC3. COVAD will provide the transmission equipment at its site and the associated transport fiber to the BELL ATLANTIC designated splice point in the central office.
- 2.5.7.14** In the event COVAD has designated transmission equipment for its dedicated use that is not normally used by BELL ATLANTIC, the contractual arrangement will be made for a period of no less than five years to be used as the useful life of the equipment in developing rates. Terminations of the Virtual Collocation arrangement using this specific transmission equipment before the end of the five year period will result in a termination charge equal to the number of months remaining to reach five years multiplied by the monthly rate.
- 2.5.7.15** If COVAD fails to pay the charges COVAD will be subject to suspension or termination of service for nonpayment, as

specified elsewhere in this Agreement. Late payments shall be subject to a monthly late charge if payment is not received by the due date. The late charge will be calculated based on 1.5% per month of the unpaid amount.

2.5.7.16 Installation interval for Virtual Collocation will be determined on an Individual Case Basis since Virtual Collocation is dependent on the type of equipment and particular arrangement that COVAD requests.

2.5.8 Rates and Charges

Rates and Charges are determined on an Individual Case Basis (ICB) after receipt of an application fee as specified in Part IV. The application fee will be applied to the non-recurring fees for the arrangement if COVAD accepts and proceeds with the arrangement.

3. Rights of Way

BELL ATLANTIC shall provide to COVAD access to its rights of way ("ROW"), conduits, ducts and pole attachments on the terms and conditions including, without limitation, prices, consistent with the terms and conditions in its current license agreements ("License Agreements"). BELL ATLANTIC agrees to abide by the Commission's decision in Case No. 95-C-0341 with respect to access by COVAD to BELL ATLANTIC's ROW, conduits, ducts and pole attachments and shall, to the extent required by the Commission in that decision, amend such License Agreements and applicable tariffs.

4. Dark Fiber

BELL ATLANTIC shall not be required to provide or lease dark fiber (i.e., fiber optic transmission facilities that are deployed but are not equipped at either end with electronics and are not in use).

Exhibit A to Part III

1. Physical Collocation Turnover Failure

Pursuant to Part III Section 2 for Collocation, COVAD shall order physical collocation space and BELL ATLANTIC shall provide such space. Subject to the limitations set forth in subsection (3) below, if BELL ATLANTIC fails to turnover a physical collocation space in accordance with the installation intervals specified in Part III Section 2 ("Turnover Failure") and such Turnover Failure continues beyond 120 business days from the Start Date, BELL ATLANTIC shall credit COVAD five hundred U.S. dollars (\$500) per business day beginning on the 121st business day from the Start Date. Such credits shall continue until BELL ATLANTIC provides the turnover of the physical collocation space. In the event the total credit for the Turnover Failure of any particular collocation space exceeds the cumulative payments that COVAD has paid to BELL ATLANTIC for that collocation space, those credits will not be applied until COVAD's payments for that collocation space exceed the credit for the delayed turnover of that particular collocation space. Notwithstanding the foregoing, at no time shall the total credit exceed 30% of the total nonrecurring charges for the particular physical collocation space.

2. Joint Planning and Forecasts

The Parties agree to work cooperatively to forecast, plan and administer COVAD's collocation space requirements. Within 60 days of the Effective Date of this Agreement, COVAD shall submit a one year forecast of its collocation space demand including a prioritization of such demand by location, the space required and the general characteristics of the physical collocation space required (including power requirements, equipment to be placed in the collocation space and the types and quantities of terminations). COVAD shall update its forecast quarterly thereafter. Initially, the Parties shall meet within 90 days of the Effective Date of this Agreement to review COVAD's forecast and undertake joint planning for collocation. Thereafter, the Parties shall meet quarterly to review such forecasts and undertake joint planning.

3. Limitations

The following limitations shall apply to the credits set forth in subsection (1):

- a) If BELL ATLANTIC's Turnover Failure is caused, directly or indirectly, by a Delaying Event, the installation intervals shall be extended twice as long as the Delaying Event was in effect. A "Delaying Event" means (i) a failure by COVAD to perform any of its obligations set forth in this Agreement; (ii) any delay, act or failure to act by COVAD or its customer, agent, vendor, affiliate, representative or subcontractor; (iii) any Force Majeure Event; or (iv) such other delay, act or failure to act upon which the Parties may agree.
- b) If COVAD submits more than one (1) collocation application in any one day, the Start Date shall be that date for the first collocation application submitted on that date. The Start Date for each successive collocation application submitted on that date shall be the next business day following the Start Date for the immediately preceding application. By way of example only, if COVAD submits three applications on January 1, the first Start Date will begin on January 1, the second on January 2 and the third on January 3.
- c) Credits will only apply to the first ten (10) physical collocation applications submitted in any one month, provided that credits will not apply to more than five (5) physical collocation applications submitted in that month for Collocation Premises with insufficient conditioned collocation space.
- d) If at any time COVAD has ten (10) or more collocation spaces which have not become materially operational ("Non-Operational Cages") within a period of sixty (60) business days from the date on which BELL ATLANTIC completed such collocation spaces, then, for each day that the number of Non-Operational Cages exceeds nine (9) cages, COVAD shall waive one day's credit for any Turnover Failure relating to any collocation application in progress or completed during the period that the number of Non-Operational Cages exceeded nine (9) cages. For purposes of this Agreement, "materially operational" means that COVAD has installed all necessary equipment in the collocation space and has ordered the necessary services from BELL ATLANTIC within the appropriate time frames to permit COVAD to provide telecommunications services to its customers.

4. Sole Remedy

In the absence of gross negligence or willful misconduct, the credit described herein shall be the sole and exclusive remedy available for any Turnover Failure by BELL ATLANTIC regardless of the existence or availability of any other remedy procedure or process available to COVAD at law or equity, and shall apply irrespective of any other determinations made with respect to other carriers in PSC Case No. 97-C-0139.

Appendix A

COLLOCATION SCHEDULE

CONTRACT # _____

CAGE # _____

PARTITIONED SPACE # _____
(ACTL #)

THIS COLLOCATION SCHEDULE IS MADE THIS ____ DAY OF _____, 19 ____,
AND SUBJECT TO ALL DEFINITIONS, TERMS AND CONDITIONS OF THE
INTERCONNECTION AGREEMENT DATED _____, 19 ____, BETWEEN
NEW YORK TELEPHONE AND _____
(INTERCONNECTOR).

A. APPLICATION FEE FOR OCCUPANCY \$ _____

B. COLLOCATION SPACE(S) MONTHLY LICENSING FEES

NYT CENTRAL OFFICE _____

FLOOR: _____

RATES AND FEES - SPACES:

	A	B	(AXB)	MONTHLY
1. PARTI-	<u>RATE</u>	<u>AREA</u>	<u>ANNUAL</u>	<u>LICENSE</u>
TIONED			<u>LICENSE FEE</u>	<u>FEE</u>
SPACE	_____	_____	_____	_____

2. CABLE SPACE	<u>RATE</u>	# OF FIBER <u>CABLES</u>	ANNUAL <u>LICENSE FEE</u>	MONTHLY <u>LICENSE FEE</u>
PRIMARY ROUTE SPACE	_____	_____	_____	_____
PER CABLE PER LINEAR ¹ FOOT	_____	_____	_____	_____
ALTERNATE ROUTE SPACE PER CABLE PER LINEAR ⁵ FOOT	_____	_____	_____	_____

3. CONDUIT SPACE	<u>RATE*</u>	<u>DISTANCE</u>	ANNUAL <u>LICENSE FEE</u>	MONTHLY <u>LICENSE FEE</u>
PRIMARY ROUTE	_____	_____	_____	_____

¹LINEAR FOOTAGE IS COMPUTED AS THE SUM OF THE LENGTHS AS FOLLOWS:

1. HORIZONTALLY - FROM THE CABLE VAULT ENTRANCE WALL AS RUN TO THE RISER LEADING TO THE HIGHER FLOORS IN THE BUILDING.
2. VERTICALLY - FROM THE ENTRANCE HEIGHT IN THE VAULT, AS RUN, TO THE PHYSICAL TERMINATION AT THE POINT OF TERMINATION.
3. HORIZONTALLY - FROM THE RISER ON THE COLLOCATED INTERCONNECTOR'S FLOOR, AS RUN, TO THE POINT OF TERMINATION.

ALTERNATE
ROUTE

RATES AND
FEES- POWER

	A	B	(AXB) ANNUAL	MONTHLY
	<u>RATE</u>	<u>AREA**</u>	<u>LICENSE FEE</u>	<u>LICENSE FEE</u>
4. D.C. POWER (48 VOLT WITH BATTERY BACK-UP)	_____	_____	_____	_____
5. EMER- GENCY A.C. POWER (OPTIONAL)	_____	_____	_____	_____

⁵ CONDUIT RATES & DESCRIPTION

RATE 1: \$ _____ /DUCT FT./PER MONTH X 12 MONTHS = \$ _____

\$ _____ PER DUCT FOOT IS APPLIED WHERE THE INTERCONNECTOR'S CABLE EXCEEDS 1.1" IN OUTSIDE DIAMETER OR WHERE THE INTERCONNECTOR HAS PLACED TWO OR MORE CABLES WITHIN A SINGLE DUCT REGARDLESS OF SIZE.

RATE 2: \$ _____ /DUCT FT./PER MONTH X 12 MONTHS = \$ _____

\$ _____ PER DUCT FOOT IS APPLIED WHERE THE INTERCONNECTOR HAS ONLY ONE CABLE IN A DUCT AND THAT CABLE IS EQUAL TO OR LESS THAN 1.1" IN OUTSIDE DIAMETER. IN THAT EVENT, NYT RESERVES THE RIGHT TO USE OR TO LICENSE OTHERS TO USE THE REMAINDER OF THE USABLE SPACE WITHIN THAT DUCT.

** D.C. POWER AND EMERGENCY A.C. POWER FEES ARE DETERMINED BY THE AREA OF PARTITIONED SPACE ABOVE.

OCCUPANCY FEE

OCCUPANCY FEE REPRESENTS THE TOTAL ANNUAL/MONTHLY LICENSE AND POWER FEES DESCRIBED ABOVE.

\$ _____ TOTAL ANNUAL \$ _____ TOTAL PER MONTH

TIME AND MATERIALS \$ _____

ESCORT FEE \$ _____

C. COLLOCATION SPACE(S) NON RECURRING CHARGES

1. DESIGN AND CONSTRUCTION

THIS SCHEDULE DEPICTS THE ACCOUNTING OF THE DESIGN AND CONSTRUCTION WORK ESTIMATE FOR WORK NYT SHALL ARRANGE, MANAGE, AND PERFORM TO EITHER CONSTRUCT OR PREPARE THE PARTITIONED SPACE, CABLE SPACE, VAULT SPACE, AND CONDUIT SPACE FOR TURNOVER TO THE INTERCONNECTOR FOR OCCUPANCY AND IN ACCORDANCE WITH THE TERMS AND CONDITIONS OF THE INTERCONNECTION AGREEMENT. THE FOLLOWING CHARGES APPLY:

TOTAL ESTIMATE

\$ _____

FIRST INSTALLMENT

(50% OF ESTIMATE)

\$ _____

2. SECURITY FEE

THE AMOUNT OF \$_____ (AT THE VALUE OF SIX MONTHS OF OCCUPANCY FEES) SHALL BE HELD BY NYT. FOR THE DURATION OF THE AGREEMENT AND SHALL BE RETURNED TO THE INTERCONNECTOR, WITH INTEREST AS DESCRIBED IN. AND, UPON COMPLETION OF THIS AGREEMENT LESS ANY AMOUNTS DUE AND OWED BY THE INTERCONNECTOR AT THE TIME OF TERMINATION.

D. TURNOVER OF SPACE(S)

THE INTERVAL FOR TURNOVER OF SPACES SHALL BE IN ACCORDANCE WITH THE TERMS OF THE INTERCONNECTION AGREEMENT.

E. TERMS

THE TERM OF THIS AGREEMENT SCHEDULE SHALL COMMENCE AS OF THE OCCUPANCY DATE.

APPROVED BY:

(INTERCONNECTORS NAME) NEW YORK TELEPHONE

NAME - TYPE OR PRINT

NAME - TYPE OR PRINT

SIGNATURE

SIGNATURE

DATE

DATE

NOTE:

1. THE TOTAL ESTIMATE IS BASED ON KNOWN COSTS PRIOR TO DETAILED ENGINEERING REVIEW. A FINAL BILL WILL BE RENDERED TO RECONCILE THE ESTIMATE WITH THE ACTUAL COSTS. NYT SHALL INFORM INTERCONNECTOR OF ANY ADDITIONAL COSTS WHICH COULD SIGNIFICANTLY ALTER THE FINAL BILL FROM THE TOTAL ESTIMATE AS THESE COSTS BECOME KNOWN.

Appendix B
Application for Collocation

BELL ATLANTIC PHYSICAL COLLOCATION APPLICATION

- 1) COLLOCATOR _____
 - 2) ADDRESS _____
 - 3) CONTACT _____
 - 4) TEL # _____
 - 5) FAX # _____
 - 6) ACNA _____
-

DESIRED COLLOCATION SITE

- 1) CENTRAL OFFICE _____
 - 2) ADDRESS _____ CLI _____
 - 3) TOWN _____
-

SPECIFIC FLOOR SPACE REQUIREMENTS

- 1) NUMBER OF EQUIPMENT FRAMES TO BE INSTALLED _____
 - 2) AMOUNT OF SPACE REQUESTED _____ (100 SQ.FT.MIN)
 - 3) ATTACH FLOOR PLAN LAYOUT FOR SPACE (FOOTPRINT)
-

TYPE OF SERVICE

CHECK DESIRED SERVICES & ENTER QUANTITY REQUIRED:

- 1. OTIS II DIGITAL DS3 _____ QTY _____
 DS1 _____ QTY _____
 DS0 _____ QTY _____
- 2. VOICE GRADE SNAPS _____ QTY _____
 SVGALS _____ QTY _____

3. IS SYNCHRONIZATION/TIMING REQUIRED? YES OR NO

TECHNICAL EQUIPMENT SPECIFICATIONS

1. SPECIFIC DC POWER REQUIREMENTS:

-48V BATTERY & GROUND, A&B SUPPLIES, # OF FEEDS (A&B) _____
(Quantity of "1" equals 1 A&B Feed Pair)

NUMBER OF AMPS (DRAIN) REQUIRED PER A&B FEED _____
(Qty of "30" equals 30 Amps on A & 30 Amps on B - DO NOT ADD TOGETHER)

2) LIST OF CUSTOMER'S EQUIPMENT TO BE INSTALLED:

MANUFACTURER/MODEL #	HEAT DISSIPATION (WATTS)	QTY	CLEI
A) _____	_____	_____	_____
B) _____	_____	_____	_____
C) _____	_____	_____	_____
D) _____	_____	_____	_____
E) _____	_____	_____	_____
F) _____	_____	_____	_____

PLEASE ATTACH MANUFACTURER'S SPECIFICATIONS FOR EACH PIECE OF EQUIPMENT

OUTSIDE PLANT CABLE INFORMATION

1) CABLE INFORMATION

A) DIRECTION FROM WHERE CABLE IS ORIGINATING? (BE SPECIFIC)

B) HAVE LICENSING AGREEMENTS FOR THIS LOCATION BEEN ESTABLISHED?

YES OR NO

IF YES, PROVIDE CONTRACT NUMBER _____

C. IS ROUTE DIVERSITY REQUESTED - YES OR NO?

PROVIDE DETAILS _____

D) <u>TYPE OF OSP CABLE</u>	<u>FEEDER / RISER CABLE</u>
1. NUMBER OF CABLES TO BE PLACED	_____/_____
2. TYPE OF CABLES (VENDOR'S NAME)	_____/_____
3. SIZE OF CABLES (DIAMETER)	_____/_____
4. NUMBER OF FIBERS	_____/_____
5. OTHER	_____/_____

NOTE: FIBER OPTIC RISER CABLES MUST BE APPROVED BY TELESECTOR RESOURCES GROUP (212) 338-7000. RISER CABLE & SPLICE ENCLOSURE MUST BE FIRE RETARDANT.

CUSTOMER'S VENDOR SELECTION

1) OUTSIDE PLANT VENDOR FOR CABLE PLACEMENT _____
ADDRESS _____
TELEPHONE # _____

2) INSTALLATION VENDOR FOR CUSTOMER'S EQUIPMENT _____
ADDRESS _____
TELEPHONE # _____

3) ENGINEERING VENDOR FOR CUSTOMER'S EQUIPEMNT _____
ADDRESS _____
TELEPHONE # _____

Appendix C
Form of Insurance Certificate

Insurance Certificates meeting the requirements of this Agreement will be submitted per collocation request.

Appendix D
Technical References and Generic Criteria
for Network Telecommunication Equipment

Technical References:

GR-003 Network Equipment Building Requirements

TR-NWT-001089 - Electromagnetic Compatibility and Electrical Safety

Generic Criteria for Network Telecommunication Equipment

TR-NWT-000078 - Generic Physical Design Requirements for Telecommunications Products and Equipment.

TR-NWT-00513 - Power & Isolated Ground Planes.

TR-NWT-000295 - Isolated Ground Planes Definition & Application to Telephone Central Offices

NIP 74160 - BELL ATLANTIC Information Standards for Central Office Installation and Removal Procedures.

NIP 74162 - BELL ATLANTIC Information Standards for Central Office Grounding

Appendix E

Form of Design and Construction Work Completion Notice

PART IV: PRICING SCHEDULE

A. UNBUNDLED NETWORK ELEMENTS

FCC Element	Rate Elements	Rate Unit	Final Rates	
			Major City	Rest of State
LINK (Local Loop) ²				
	2 Wire Analog	Per Link/Mo	12.49	19.24
	2 Wire Conditioned	Per Link/Mo	21.02	28.26
	4 Wire Analog	Per Link/Mo	27.67	41.37
	4 Wire Conditioned	Per Link/Mo	98.32	112.29
	2 Wire ADSL	Per Link/Mo	TBD*	TBD*
	2 Wire HDSL	Per Link/Mo	TBD*	TBD*
	4 Wire HDSL	Per Link/Mo	TBD*	TBD*
	DS3 Loop	Per Link/Mo	911.00	911.00
	DS3 Loop Mileage	Per 1/4 mile/Link/Mo	20.10	20.10
SWITCHING			Statewide	
LOCAL				
<u>Local Ports</u>				
	• Analog Line Port	Port/Mo		2.50
	• Digital Port	Per DSO equivalent/Mo		2.50
	• ISDN-BRI Port	Port/Mo		11.77
	• Dedicated. Digital Trunk	Per DSO equivalent/Mo		6.75
	• ISDN-PRI	DS1 Port/Mo		184.64
<u>Usage</u>				
	• Common Trunk-	Per MOU		.000879

Includes NID

M:\Kw24778\Covad\Covadny4.Doc

FCC Element	Rate Elements	Rate Unit	Final Rates
	Day		
	• Common Trunk-Even.	Per MOU	.000214
	• Common Trunk-Night	Per MOU	.000095

FCC Element	Rate Elements	Rate Unit	Final Rates
	• Usage-Day	Per MOU	.003806
	• Usage-Even.	Per MOU	.001837
	• Usage-Night	Per MOU	.001508
<u>Port Additives:</u>			
	• Centrex	Per Port/Mo	.45
	• Ringmate	Per Port/Mo	.52
	• Three-Way Calling	Per Port/Mo	.16
TANDEM			
<u>Tandem Ports</u>			
	• Digital Dedicated	Per DSO equivalent/Mo	5.28
<u>Usage</u>			
	• Common Trunk-Day	Per MOU	.001958
	• Common Trunk-Even.	Per MOU	.000476
	• Common Trunk-Night	Per MOU	.000229
	• Usage-Day	Per MOU	.001156
	• Usage-Eve.	Per MOU	.000741
	• Usage-Night	Per MOU	.000670

FCC Element	Rate Elements	Rate Unit	Final Rates
TRANSPORT	←————→	(Source NY PSC 916 Tariff)	←————→
	<u>Dedicated</u>		
	• OC-48	Rate/Mo = Fixed + Per mile Charge	9,768 + 375.81/mile
	• OC-12	Rate/Mo = Fixed + Per mile Charge	4,145 + 241.21/mile
	• OC-3	Rate/Mo = Fixed + Per mile Charge	1,365 + 60.31/mile
	• DS-3	Rate/Mo = Fixed + Per mile Charge	911 + 20.10/mile
	• DS-1	Rate/Mo = Fixed + Per mile Charge	110 + .72/mile
	• CO Multiplexing	Per arrangement per central office/Mo	Per PSC No. 916 Tariff
	<u>Common</u>		
	• Usage-Day	Per MOU	.001040
	• Usage-Even	Per MOU	.000548
	• Usage-Night	Per MOU	.000000
SIGNALING			
	<u>Signal Transfer Point</u>		
	• STP Port	Per port/Mo	775.22
	• Signaling Link	Per DSO/Mo	31.97
	<u>Signaling Query</u>		
	• 800 Service	Per query	.001265
	• LIDB Service	Per query	.001411

FCC Element	Rate Elements	Rate Unit	Final Rates
Reciprocal Compensation	<u>Local Switch - Meetpoint A</u>		
	• Usage-Day	Per MOU	.004685
	• Usage-Even.	Per MOU	.002051
	• Usage-Night	Per MOU	.001603
	<u>Tandem - Meetpoint B</u>		
	• Usage-Day	Per MOU	.010797
• Usage-Even.	Per MOU	.004292	
• Usage-Night	Per MOU	.002731	

B. OTHER RATES (See Section A for unbundled Network Element Rates)

I. Reciprocal Compensation

End Office Rate ("Meetpoint A"):

Local Switching Usage Rate
+ Local Switching Common Trunk Rate
End Office Rate

Tandem Rate ("Meetpoint B"):

End Office Rate
+ Tandem Switching Usage
+ 2 Tandem Common Trunk Rates
+ Common Transport
Tandem Rate

A credit will be given for one Tandem Trunk if a dedicated tandem port is used.
Subject to provisions identified in Subsection 10.6 (g)

II. Information Services Fees

Billing and Collecting Fee (per message) = \$.08
Blocking Service **

III. BLV/BLVI Traffic*

Unbundled Line Rate*

\$1.00 per Busy Line Verification

\$2.25 per Busy Line Verification Interrupt

IV. Transit Service

A. Transit Service

True-Up. With respect to the items marked with an asterisk, such items shall, on an interim basis, be the charges currently noted in this Part IV (the "Interim Rates"). On the earliest of the date (the "Rate Determination Date") on which (x) any permanent rate and/or rate structures for such items are approved or adopted by the Commission in Cases 95-C-0657, 94-C-0095 and 91-C-1174 or other applicable effective Commission orders, decisions, rules or regulations or (y) the Parties shall agree to any such permanent rate and/or rate structures for such items, the rates and/or rate structures so adopted or approved or agreed upon (each, a "Permanent Rate") shall apply in lieu of the Interim Rates with respect to such items. Within 90 days after the Rate Determination Date of any Permanent Rate with respect to any item (i) if the aggregate amounts paid by COVAD for such item under this Agreement during the period commencing with the filing by BELL ATLANTIC of the applicable cost(s) or rate with the Commission prior to the Rate Determination Date shall exceed the amount which would have been payable by COVAD if the Permanent Rate (which may be zero) had been applicable during such period, then BELL ATLANTIC shall refund to COVAD such excess or (ii) if the aggregate amounts paid by COVAD for such item under this Agreement during such period commencing with the filing by BELL ATLANTIC of the applicable cost(s) or rate with the Commission prior to the Rate Determination Date shall be less than the amount which would have been payable by COVAD if the Permanent Rates had been applicable during such period, then COVAD shall pay such deficiency to BELL ATLANTIC. This Part IV shall be amended to reflect the determination of Permanent Rates for any given items.

The prices marked with a double asterisk will, on an interim basis, be zero, subject to true-up, if any, in accordance with the provisions of the preceding paragraph once Permanent Rates, if any, have been established.

Rate = Sum of applicable tandem switching usage rate and any additional tandem common trunk or tandem port charges rates in Section A of this Part IV.

B. Dedicated Transiting Service: Cage to Cage

Two times the appropriate Service Access Charges as set forth in applicable tariffs.

V. Interim Number Portability

As per the P.S.C. 914 Tariff. Terminating IXC access charges shall be shared as required by the Commission between BELL ATLANTIC and COVAD pursuant to meet-point billing arrangements between the Parties using special estimated studies until such time as actual meet-point billing records are available.

VI. IntraLATA 800

- A. Reciprocal Compensation (refer to I above).
- B. Compensation for records exchanged per record (see Section XI.B.1).*
- C. 800 Database inquiry: \$.001265 per database inquiry.

VII. Intentionally Omitted

VIII. 911/E911 Interconnection

- A. Monthly Rate = \$252 per month for an unequipped DS1 Port and \$100 per month per voice grade trunk activated and equipped on the DS1 port.*
- B. \$.05 per line per month for UNE switched lines.*

IX. [Intentionally Omitted]

X. Directory Assistance and Operator Services-Network Elements

(A) Directory Assistance Services

(1) Directory Assistance

Per Request

Each Request for Information per one telephone number, with BELL ATLANTIC branding

\$0.39

Each Request for Information per one telephone number, with COVAD branding

\$0.39

Each Request for Information per one telephone number, without branding

\$0.33

Branding surcharge per call (if applicable)

\$0.06

(2) Directory Assistance Call

Completion (DACC) #:

Each Request for Information per one telephone number, with COVAD branding or with BELL ATLANTIC branding plus call completion

\$0.58

Each Request for Information per one telephone number, without branding plus call completion

\$0.52

DACC Surcharge per call

\$0.19

These rates are in addition to the UTTC, TTSC & UNRCC or UCRCC charges.

(3) Record Charges

EMR format - per record charge

\$0.0102

(4) Direct Access to Directory Assistance (DADA)

Monthly Access Charge	\$4000
Each Search Request	\$0.038

		<u>Rate</u>
(B)	Inward Operator Services#	
	(1) BLV, Per work second	\$0.02
	(2) BLV/I, Per work second	\$0.02
	(3) Branding surcharge, per call (if applicable)	\$0.06

(C)	0+/Mechanized Operator Calls #	
	(1) Calling Card, Per request	\$0.125
	(2) Collect, Per request	\$0.159
	(3) Third Number, Per request	\$0.159
	(4) Branding surcharge, per call (if applicable)	\$0.06

These rates are in addition to the UTTC, TTSC & UNRCC or UCRCC charges.

(D)	0- Operator Handled Calls #	
	(1) Per work second Plus	\$0.015
	(2) Collect & Bill to Third Number, Per request	\$0.007
	(3) Branding surcharge, per call (if applicable)	\$0.06

These rates are in addition to the UTTC, TTSC & UNRCC or UCRCC charges.

(E)	Operator Emergency Bulletin Service, Per 132 LATA bulletin, per year	\$81.18
-----	---	---------

(F)	TOPS Trunk Ports	<u>Recurring</u> \$524.88	<u>Non-recurring</u> \$315.06
	Service Access Charge, Per TOPS Port	\$4.31	N/A

(G)	IOF mileage for Dedicated Trunk Transport	\$110.00	\$525.00
	Mileage charge, per mile per month		\$0.72

	<u>Day</u>	<u>Evening</u>	<u>Night</u>
Shared Trunk Port - per MOU	\$0.000879	\$0.000214	\$0.000095
Unbundled Local Switching - per MOU	\$0.003806	\$0.001837	\$0.001508
Unbundled Tandem Transport (UTTC) - per MOU	\$0.001040	\$0.000548	\$0.000000
Tandem Transit Switching (TTSC) - per MOU	\$0.006472	\$0.003093	\$0.002528
Telephone Company Reciprocal Compensation (UNRCC) - per MOU	\$0.006085	\$0.003451	\$0.003003
TC Reciprocal Compensation (UCRCC) - per MOU	\$0.006085	\$0.003451	\$0.003003

XI. Miscellaneous and Non-Recurring Charges

A. Unbundled Network Elements

1. Switch Port Additives

SMDI (per month) - \$30.00 per port plus,
if transport is ordered,
\$33.39 plus \$3.89
per mile*

2. Non-Recurring Charges

SVGAL - \$82.05 per line*
\$85 per dispatch as required*
NID - \$85 per dispatch*
Trunk Installation - \$288 per DS1*
Service Order Charge - \$105 per order*

Engineering Charge	-	\$80 per order*
Expedited Trunk Installation	-	**
Expedited Service Order Charge	-	**
Expedited Engineering Charge	-	**
Engineering Labor Rate	-	**
Translations Engineer Labor Rate	-	**
Service Representative Labor Rate	-	**
Technician Labor Rate	-	**
Testing & Other Labor Rate	-	**
SS7 Point Code Change	-	\$136.87 per first point code* \$15.80 each additional*
Dispatch-In (false)	-	\$59 per dispatch*
Dispatch-Out (false)	-	\$147.06 per dispatch*
ADSL or HDSL Non-Recurring Charges		TBD*

B. Miscellaneous

1. **Call Usage Detail Service:**

Record Processing (all records)		\$0.00429 per record*
Data Transmission - UNE		**
Tape Cartridge - UNE		**

2. **Emergency Bulletin Service:**

- NYT \$3000 per initial data plus
\$250/ monthly update*

3. Intentionally Omitted:

4. Operations Systems Access:

Per Transaction Charge - **
Monthly Data Access - **
Operations Support Charge - per MOU \$.0014*
(Single charge per MOU for any single
element)

5. Other

Record Change Charge - **
Duplicate Bill Charge - \$.12/page(paper), \$14/disk,*
\$15.96/tape*
\$.0015/record*
Data Entry Search - **
Call Blocking - **
Design Change Charge - \$113.98 per order*
AIN Query Launch Charge - **
New Rate Elements, OSS and Databases **
Special Construction/ICB requests - **

6. Intentionally Omitted

XII. A. Collocation*³

1.Cage - 1st 100 ft. - per P.S.C. 900 Tariff

³ Including conditioning charges.
M:\Kw24778\Covad\Covadny4.Doc

- 2. Cage - Add. ft. - per P.S.C. 900 Tariff
- 3. Cable Space - per P.S.C. 900 Tariff
- 4. Space - per P.S.C. 900 Tariff
- 5. Basic DW Power - per P.S.C. 900 Tariff
- 6. Additional Power - Individual Case Basis
- 7. Application Fee per P.S.C. 900 Tariff

B. Virtual Collocation

Application fee: \$2,500.00
 Other Charges: ICB

XIII. Customized Routing/Network Design Request

Unbundled Network Elements - Individual Case Basis

Prices for non-standard offering will be on an Individual Case Basis.

XIV. Alternate Billed Calls

Billing and Collection Fee - \$.05 per call

XV. NID \$.58 per month*

XVI. Branding

914 Branding Fee \$.05 per message*

XVII. Additional Charges:

Additional charges which are filed with the Commission shall apply, at a zero rate, on an interim basis. Such charges shall be trued-up as specified in this part IV, Section B, footnote entitled "True-Up." Provided, further, that, if any rate element is a duplicate of a rate element identified by a single asterisk in this Part IV, Section B, BELL ATLANTIC may assess the charge identified by the single asterisk, rather than a zero charge.

XVIII. Electronic Copies

Electronic copies of SAG	TBD
Electronic copies of NPA-NXX Features & Facilities	TBD

RATE APPLICATION RULES

1. General

- (a) Rates for elements, services or activities not listed in this Part IV shall be applied pursuant to tariffs or Commission approved rates (subject to any appropriate cost methodology, for unbundled Network Elements and other services) or, if there shall not be a tariff or Commission approved rate covering such elements, services or activities, such rates as the Parties shall agree. Such rates shall be applied as of the date of filing or submission of the proposed rates with the Commission, subject to true-up back to the date of such submission or filing. For those unbundled Network Elements and other services required to be provided by BELL ATLANTIC pursuant to Section 251 of the Act, the rates for such unbundled Network Elements and services shall be in accordance with the Act and applicable effective decisions, orders, rules and regulations of the Commission. Nothing in this subparagraph shall be construed as a waiver by COVAD of its right to contest proposed rates in appropriate proceedings before the Commission.
- (b) Those rates set forth in Part IV that are marked with a double asterisk are interim rates and no provision in these Rate Application Rules is intended to limit, nor shall any such provision be deemed to limit, the right of

COVAD to challenge before the Commission the imposition of a tariffed rate other than zero with respect to such item or the right of BELL ATLANTIC to seek approval from the Commission of a tariffed rate other than zero with respect to such item.

- (c) If either Party cannot measure time of day for purposes of rendering its bill to the other Party the other Party will, upon request (to the extent possible), provide verifiable time of day factors to the billing Party for use in rendering its bill.
- (d) Day, evening, and night shall be defined as provided in the P.S.C. 915 Tariff for Local Services and in the P.S.C. 914 tariff for all other services and elements provided under this Agreement.
- (e) Billable traffic exchanged pursuant to this Agreement shall be measured for terminating usage charges in actual conversation seconds, where available, and measured for originating usage charges in actual access seconds. Access seconds include conversation seconds plus a non-conversation time additive, which includes the message attempts ("NCTA"), consistent with current practices. Where the originating usage measured contains only conversation seconds, the Parties will agree on a methodology to convert and bill in access seconds, which will include an NCTA. The Parties shall agree on the calculation of the NCTA. The total conversation seconds and access seconds per chargeable traffic types shall be totaled for the entire processing cycle and then rounded to the next higher whole minute.
- (f) The terms and provisions of this Part IV and of Attachment 6, including, without limitation, the rates for unbundled Network Elements provided, shall be subject to, and interpreted in all respects consistently with, the applicable call flows diagram(s) annexed hereto as Exhibit A (the "Call Flows Diagrams").

2. Reciprocal Compensation

- (a) Charges for Reciprocal Compensation shall be billed in accordance with Attachment 6. Reciprocal Compensation for the termination of this traffic shall be charged at rates specified in Part IV to this Agreement.
- (b) In lieu of the Reciprocal Compensation arrangement referred to above and where permitted by state law or Commission regulation or order, the

parties may mutually agree to adopt a bill and keep compensation arrangement or such other mutually agreed upon compensation arrangement.

- (c) Reciprocal Compensation shall be priced depending on whether the traffic terminates at the carrier's end office ("Meetpoint A") or at the carrier's tandem point of interconnection ("Meetpoint B").
- (d) Where either Party uses a single trunk to carry Reciprocal Compensation Traffic and other types of traffic, such Party shall provide the other Party with verifiable factor(s) identifying the percentage(s) of such different traffic types which shall be used to determine the number of minutes of that trunk group that will be charged at each applicable rate. Factors may be updated as appropriate not more often than quarterly by the Party providing such factors to reflect the actual mix of traffic.

3. Unbundled Network Elements

- (a) "BELL ATLANTIC Shared Transport Rate" shall be the blended rate of common direct transport and common transport through tandem switched arrangements, as described in Exhibit A to this Part IV.
- (b) "Call Usage Detail Service" rates for record processing, data transmission and tape cartridge (as specified in Section XI.B of this Part IV) shall apply for end-user call-detail records transferred.
- (c) When the unbundled Local Switching Network Element is provided, COVAD shall pay rates in this Part IV for the appropriate line port charge, the appropriate local switching usage charge, and the appropriate local switching common trunk charge, based on time of day, where applicable.
- (d) When the unbundled Tandem Switching Network Element is provided, COVAD shall pay rates in this Part IV for the appropriate tandem switching usage and appropriate tandem trunk or port charges, based on time of day, where applicable.
- (e) Unbundled Local Switching Network Elements and Tandem Switching Network Elements do not include the price for STP usage charges,

CENTREX, Ring-Mate or Three-Way Calling, which will be charged separately.

- (f) Where COVAD provides its own loops to the integrated digital line port, the integrated digital line port, dedicated local switch trunk port and dedicated tandem trunk port rates can be derived by multiplying the Local Switching Digital Line Port, Local Switching Digital Trunk Port and Tandem Switching Digital Trunk rates by a factor of nineteen (19), respectively.
- (g) To the extent COVAD orders multiplexers to complete service at a level different from the dedicated transport level ordered, separate multiplexer rates shall apply.
- (h) Overflow billing from dedicated switching will be billed as BELL ATLANTIC Shared Transport. Where actual overflow MOU cannot be determined, BELL ATLANTIC will bill based on an estimate of overall traffic, as calculated in a special study with respect to overflows. The methodology for such special study shall be developed jointly by the Parties.

4. Transient Tandem Process and Pricing

- (a) COVAD may use BELL ATLANTIC's tandem switch to terminate COVAD local traffic on other local carriers' networks where such local carriers are connected to the same BELL ATLANTIC tandem, or to receive local traffic originating on such other local carriers' networks. This local traffic will route between local carriers through BELL ATLANTIC's tandem switch. When COVAD is the originating carrier terminating calls to another carrier, COVAD shall be responsible for paying BELL ATLANTIC for tandem switching, except to the extent that COVAD has already paid for tandem switching via the BELL ATLANTIC Shared Transport rate, plus a blended charge which reflects a pass through of monthly Reciprocal Compensation terminating local carrier charges paid by BELL ATLANTIC to the terminating local carrier that is based upon actual local carrier rates in effect for terminating compensation from the previous month multiplied times actual minutes of use for the given month. Since the charges for each month are calculated using actual rates from the previous month, the initial month under this Agreement will be estimated and based upon a local study. Parameters will be developed to insure that if actuals are collected in the month succeeding the initial month which differ from the estimated value by more than two thousand dollars, BELL ATLANTIC will credit COVAD for that amount which COVAD has overpaid or COVAD will pay BELL ATLANTIC for that amount which COVAD has underpaid. The prices for transient tandem switching, including all applicable associated operations support charges, are set forth in this Part IV.
- (b) When COVAD is the terminating carrier using its own (not unbundled Network Element) switching facilities, BELL ATLANTIC shall pay COVAD all terminating Reciprocal Compensation for local and toll based upon actual minutes of use and rates in effect for that month. The Parties will work cooperatively on billing disputes and uncollectible issues.

5. Links

To the extent COVAD orders a transmission interface at a level different from the level provided for the unbundled Link type ordered, separate multiplexer rates shall apply. When COVAD orders IDLC Links, additional charges may apply as set forth in Section 2.9.1(a) and (g) of Part II to this Agreement.

6. Intentionally Omitted

7. Information Services

Information Services (e.g., "976" calls). For information services, the Party ("Originating Party") shall bill and collect such information provider charges and remit an amount equal to such charges to the Party ("Terminating Party") to whose information platform the Information Services Traffic terminated less the Information Services Billing and Collection Fee set forth in Part IV. Except for Local Services Calls, upon request by the Terminating Party, the Originating Party shall provide originating call detail in unrated EMR format to the Terminating Party, at the charges specified in Part IV. Where such originating call detail is received, the Terminating Party shall provide the Originating Party with a rated record. The Originating Party shall pay the Terminating Party in full regardless of uncollectible items; provided, however, for each of its Customer's lines COVAD shall receive the forgiveness policy of two credits for each customer line after which: a) when the Originating Party provides its own local switch, the Originating Party will block all such Information Services calls originated by its Customer, b) when COVAD provides service via unbundled Network Elements or through resold Local Services, COVAD will request blocking and BELL ATLANTIC will provide blocking service at the prices set forth in Part IV. If COVAD provides its own Information Services, and BELL ATLANTIC buys such services, COVAD will provide to BELL ATLANTIC the same forgiveness policy, if any, that it applies to its customers.

BELL ATLANTIC and COVAD will work cooperatively to share Customer information regarding forgiveness for Information Services calls.

As requested by the Terminating Party, the Originating Party will provide information required by the Terminating Party to process the Originating Party's adjustment.

If, based upon review of adjustments related to Information Services forgiveness, the Terminating Party observes Originating Party adjustments that are greater than normal, the Terminating Party may request that the Originating Party share its adjustment information with the Terminating Party related to the Customer account in question to indicate the number of Information Services adjustments related to forgiveness that the Originating Party has processed for the account in question. If, after a review of these records, the Originating Party has processed more incidences of forgiveness than the forgiveness policy permits for the account in question, the Originating Party will reimburse the Terminating Party for forgiveness incidences that the Originating Party processed that would give the Customer more than the number of forgiveness incidences permitted, if the Terminating Party can demonstrate that the Terminating Party, or another carrier, notified the Originating Party of the Customer's forgiveness history prior to the Customer migrating to the Originating Party.

Intentionally Left Blank

EXHIBIT A TO PART IV

LOCAL AND TOLL CALL FLOWS AND INTERCARRIER BILLING IN THE COMPETITIVE TELECOMMUNICATIONS ENVIRONMENT

This Exhibit A covers those call flows and billing 1) between BELL ATLANTIC (hereinafter referred to as ILEC) and COVAD (hereinafter referred to as COVAD UNE), 2) between two CLECs (one of which is COVAD), and 3) between COVAD UNE and interexchange carriers (IXCs). These call flows cover scenarios when the CLEC provides service to end users 1) through total service resale (TSR), 2) through the unbundled network elements (UNE), or 3) through facility based networks (FBN).

This Exhibit A covers the call flows, UNE rate applications and billing for each of the following call types:

- Local Calls, Intra-Switch
- Local Calls, Inter-Switch
- Toll Calls, IntraLATA
- Toll Calls, Intrastate (InterLATA)
- Toll Calls, Interstate (InterLATA)
- Local 800 Calls

Notwithstanding any references to TSR or Local Services in this Exhibit A, nothing in this Exhibit A shall govern or otherwise affect the terms and conditions of Local Services.

Flat rated, monthly recurring charges and non-recurring UNE charges for switching and the Local Loop are not noted in these descriptions because they are not dependent on the call flows. Signaling and STP charges are not covered in this Exhibit A. Such charges shall be applied pursuant to Part IV of this Agreement.

COVAD shall bill all IXCs in accordance with the terms set forth in Call Flow Diagrams 21-28; provided, however, that at COVAD's option, the Parties shall negotiate in good faith to reach agreement on a billing and collection arrangement under which BELL ATLANTIC would perform local transport usage billing to interexchange carriers on COVAD's behalf.

Intentionally Left Blank

BELL ATLANTIC Shared Transport

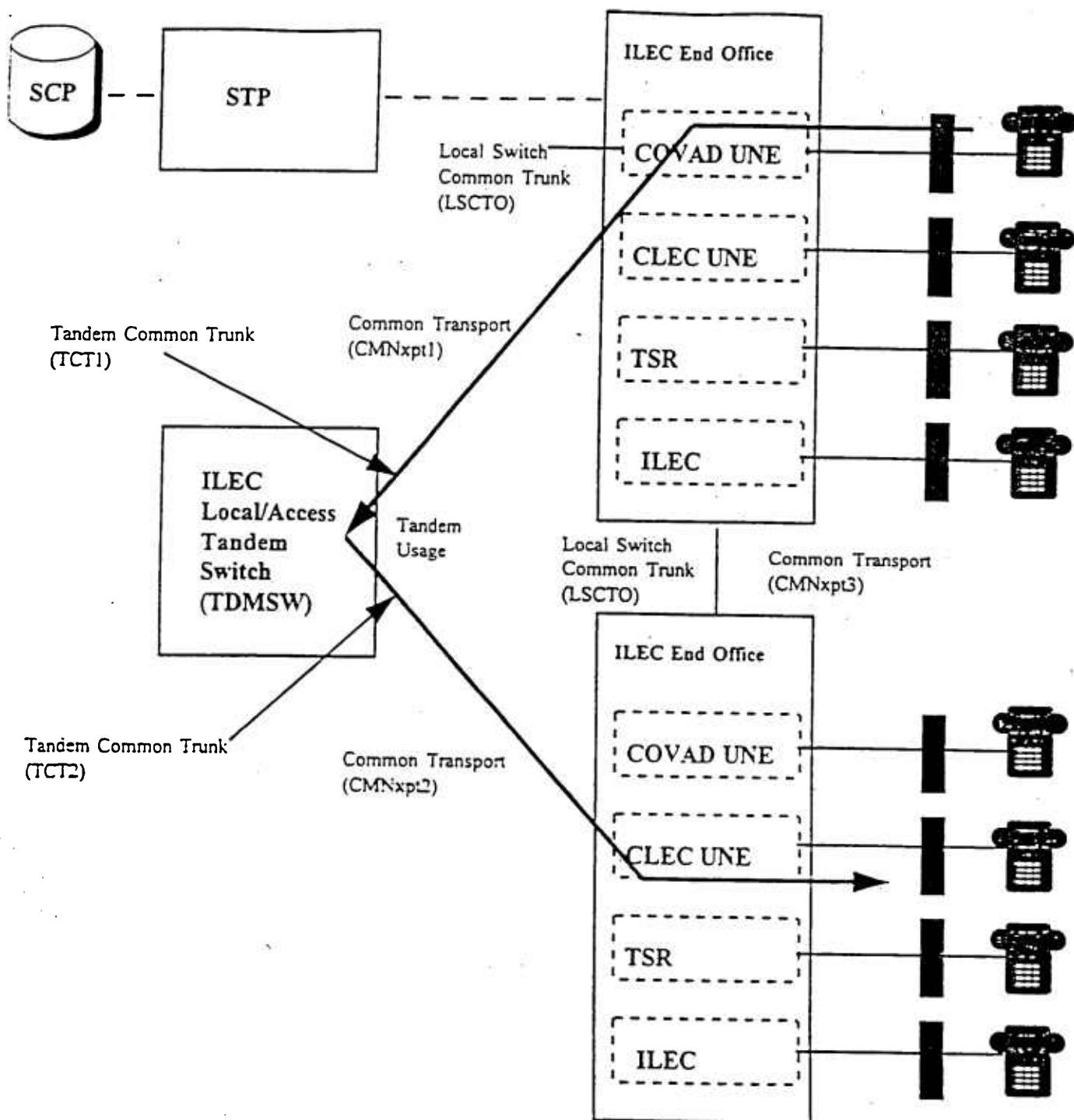

Shared Transport =

% TDM Routed (LSCTO + CMNxpt1 + TCT1 + TDM Usage + TCT2 + CMNxpt2)

+

% Direct Routed (LSCTO + CMNxpt3)

LOCAL CALLS - INTRASWITCH

UNBUNDLED NETWORK ELEMENTS

When CLECs provide local exchange service through UNE arrangements the call flows using a single switch are as follows. These scenarios assume that all CLECs are providing service through UNE and an ILEC switch.

1. COVAD UNE Originating and ILEC Terminating

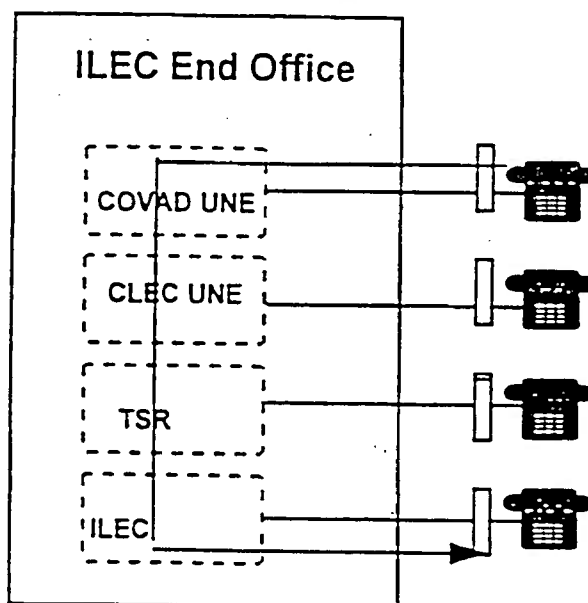

ILEC bills two UNE local switching usage charges to COVAD UNE and a Record Processing Charge

2. ILEC Originating and COVAD UNE Terminating

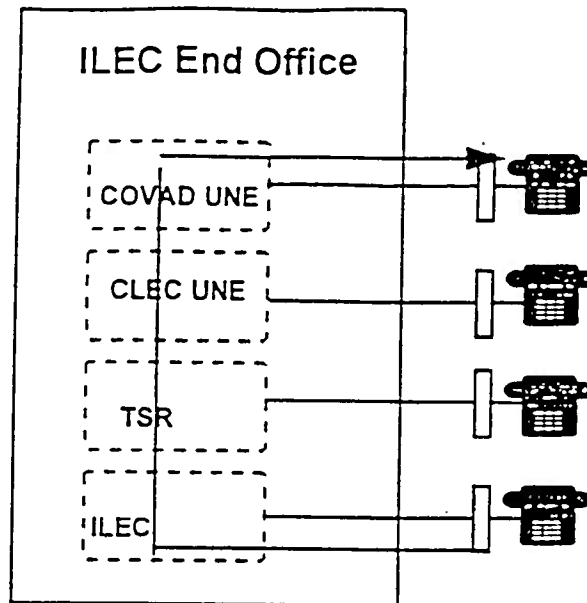

Usage charges do not apply to COVAD UNE

3. COVAD UNE Originating and CLEC Terminating

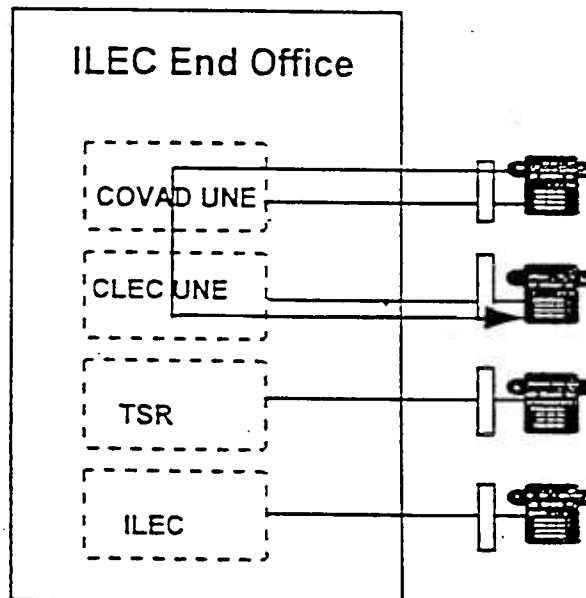

ILEC bills two UNE local switching usage charges to COVAD UNE and a Record Processing Charge. These charges apply regardless of any billing arrangements between COVAD UNE and CLEC UNE.

TOTAL SERVICE RESALE/UNBUNDLED NETWORK ELEMENTS

When one carrier provides local exchange service through a TSR arrangement and COVAD UNE provides local exchange service through UNE arrangements, the call flows using a single switch are as follows:

4. TSR Originating and COVAD UNE Terminating

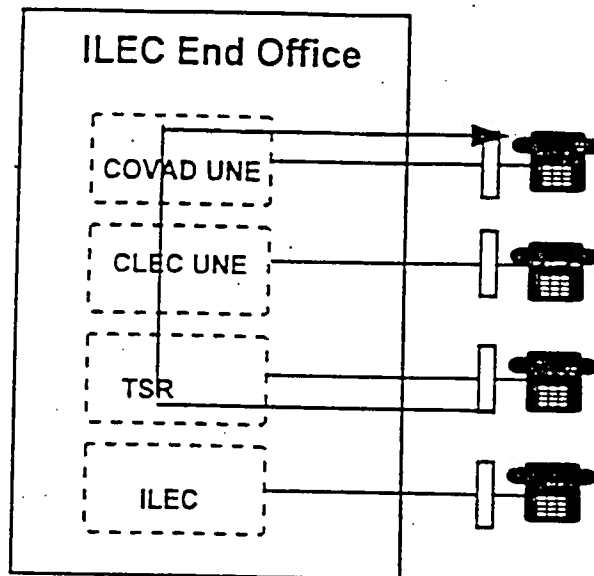

Usage charges do not apply to COVAD UNE

5. COVAD UNE Originating and TSR Terminating

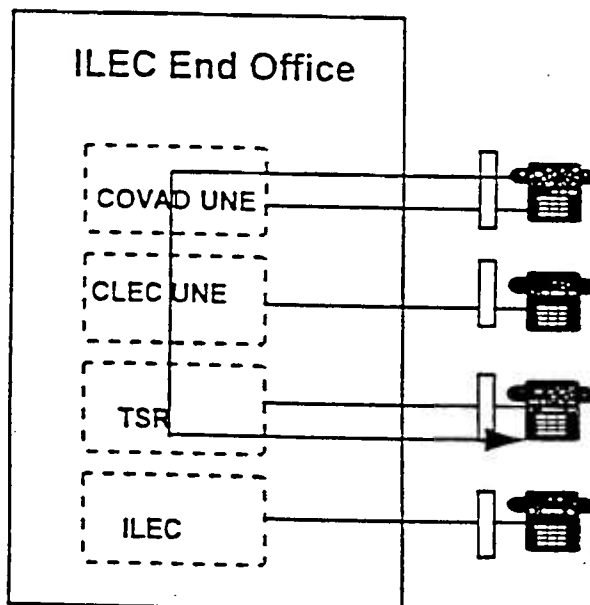

ILEC bills two UNE local switching usage charges to COVAD UNE and a Record Processing Charge. These charges apply regardless of any billing arrangements between COVAD UNE and CLEC UNE.

LOCAL CALLS - INTERSWITCH

UNBUNDLED NETWORK ELEMENTS

When COVAD UNE and another CLEC provide local exchange service through UNE arrangements the call flows through two switches are as follows. These scenarios assume that both the COVAD UNE and the other CLEC are providing service through UNE and ILEC switches:

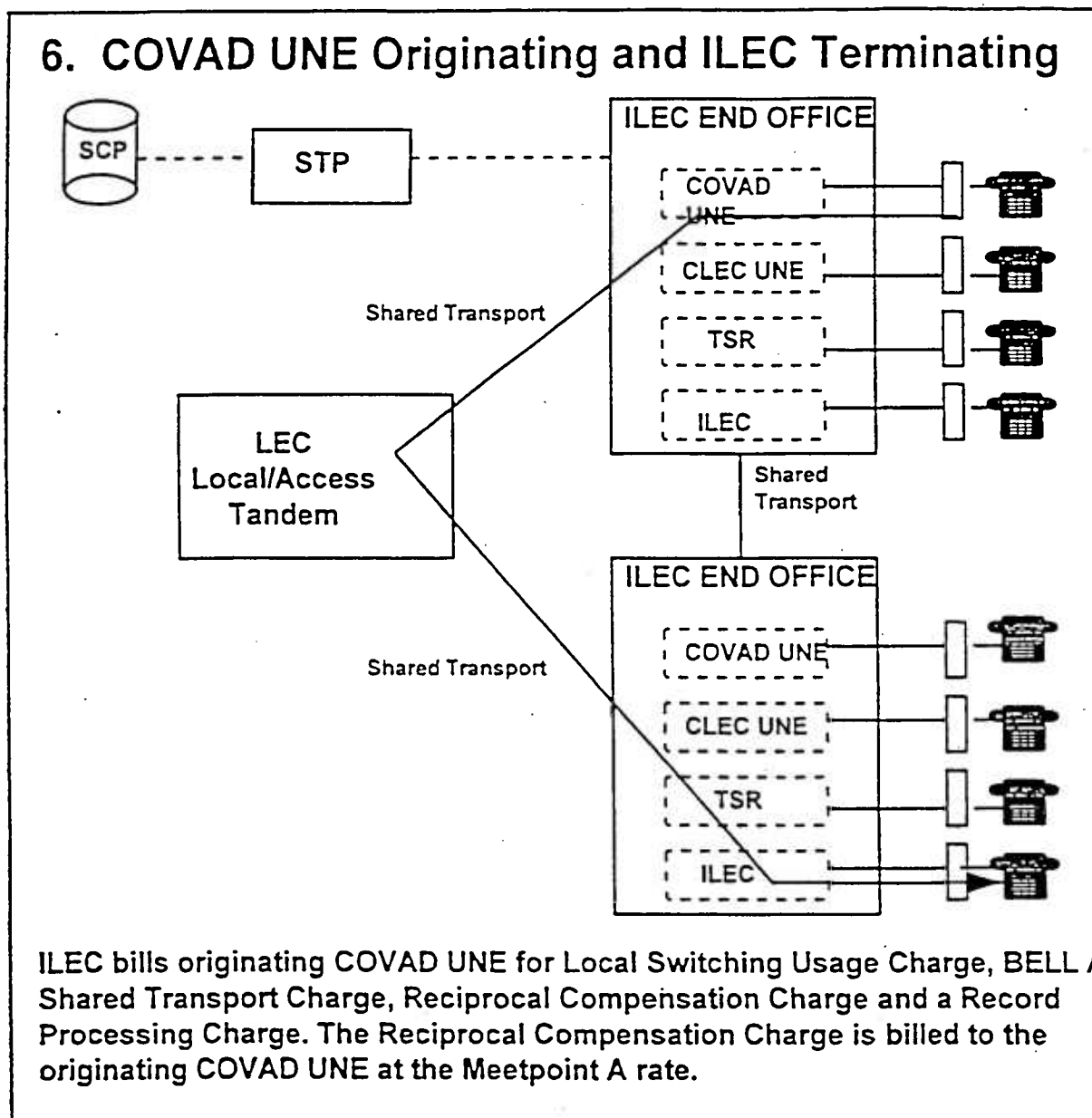

7. ILEC Originating and COVAD UNE Terminating

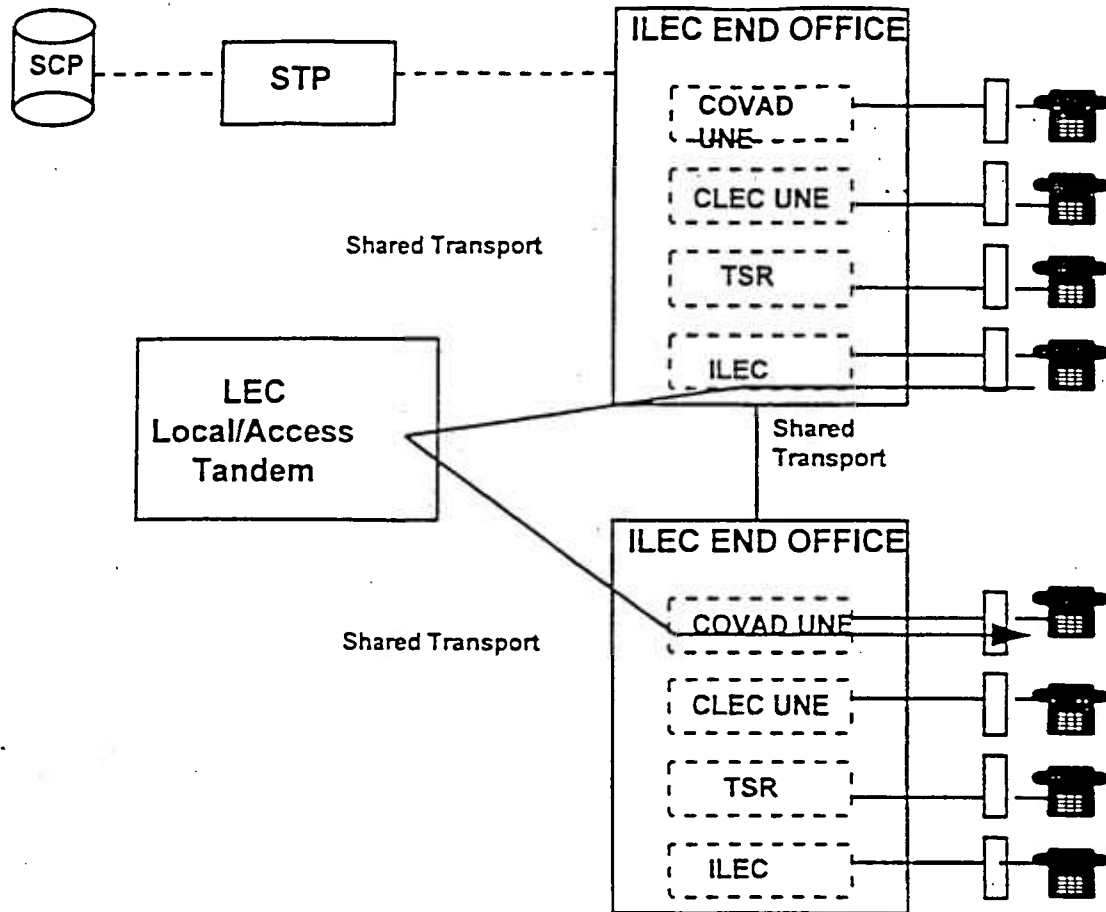

No usage charges apply to COVAD UNE.

8. COVAD UNE Originating and CLEC UNE Terminating

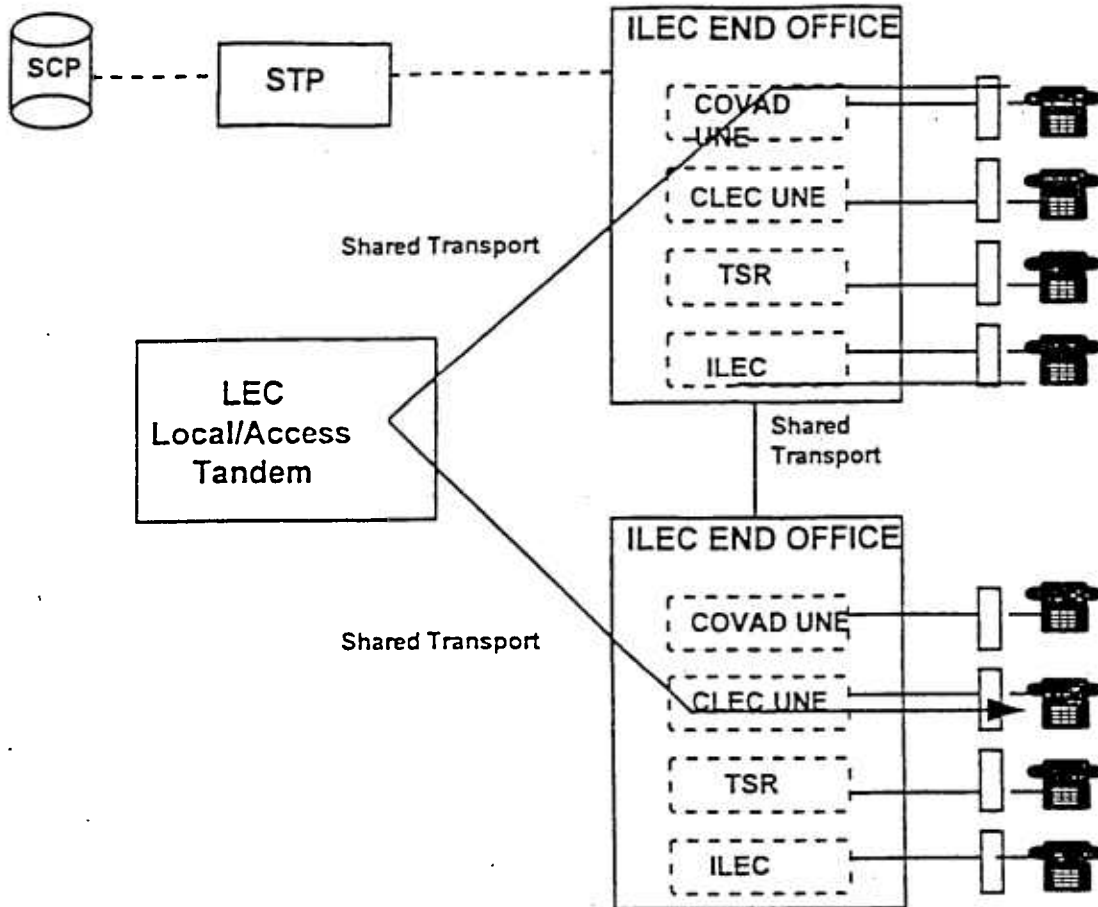

ILEC bills COVAD UNE for Local Switching Usage Charge, BELL ATLANTIC Shared Transport Charge, Reciprocal Compensation Charge and a Record Processing Charge. The Reciprocal Compensation Charge is billed to the originating COVAD UNE at the Meetpoint A rate. These charges apply regardless of any billing arrangements between COVAD UNE and CLEC UNE.

9. COVAD UNE Originating and COVAD UNE Terminating

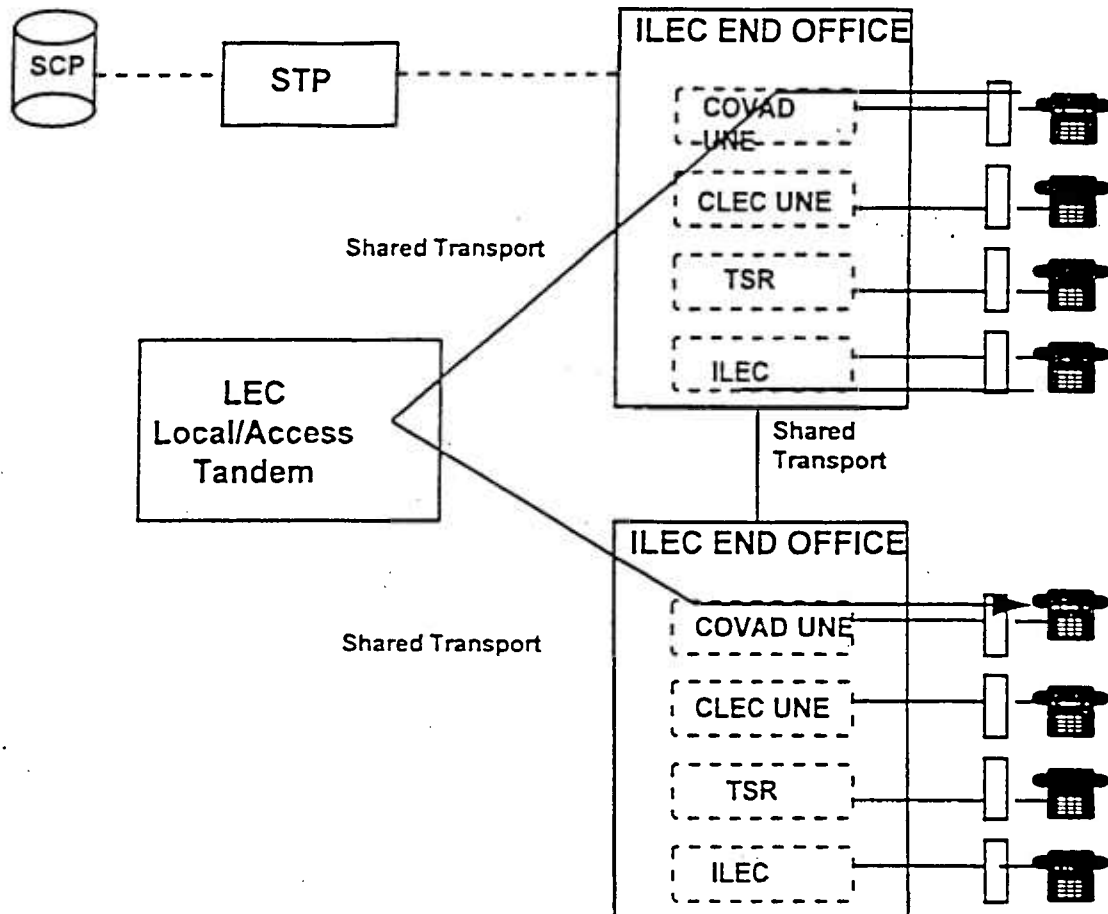

ILEC bills originating COVAD UNE for Local Switching Usage Charge, BELL ATLANTIC Shared Transport Charge, Reciprocal Compensation Charge and a Record Processing Charge. The Reciprocal Compensation Charge is billed to the originating COVAD UNE at the Meetpoint A rate. Terminating COVAD UNE will not bill ILEC reciprocal compensation charges.

10. CLEC UNE Originating and COVAD UNE Terminating

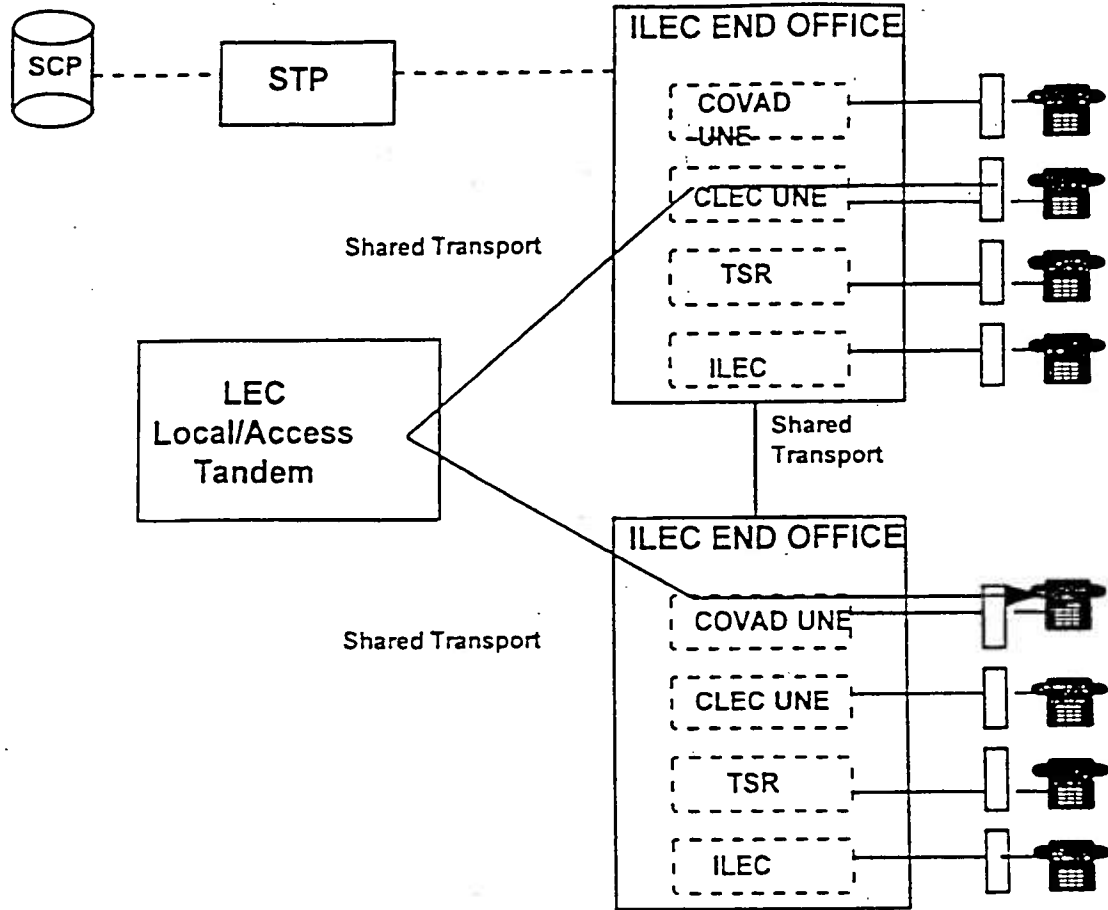

No usage charges apply to COVAD UNE.

TOTAL SERVICE RESALE [LOCAL SERVICES] UNBUNDLED NETWORK ELEMENTS

When a CLEC provides local exchange service using TSR arrangements and COVAD UNE provides local exchange service using UNE arrangements, the call flows between two switches are as follows:

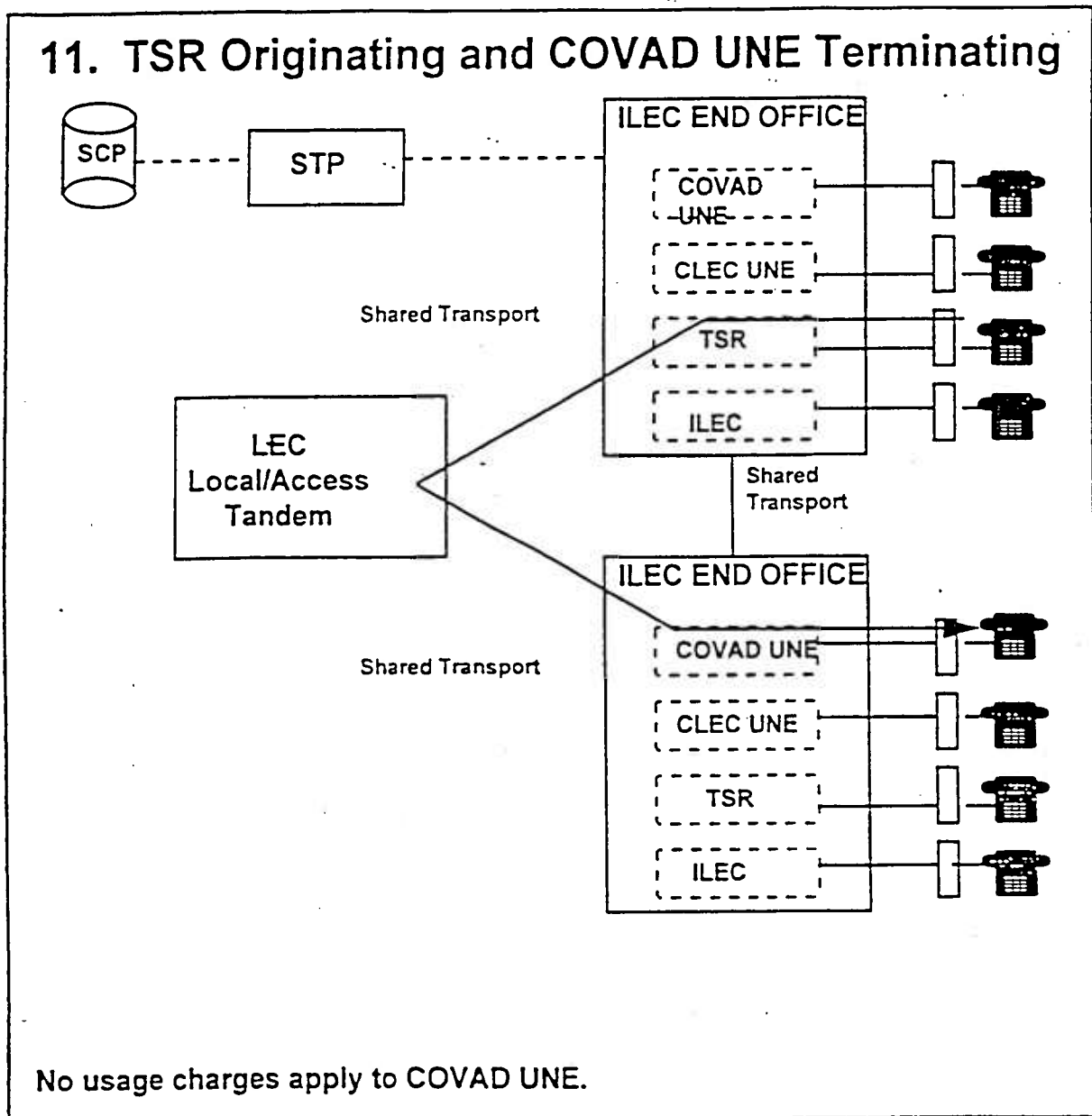

12. COVAD UNE Originating and TSR Terminating

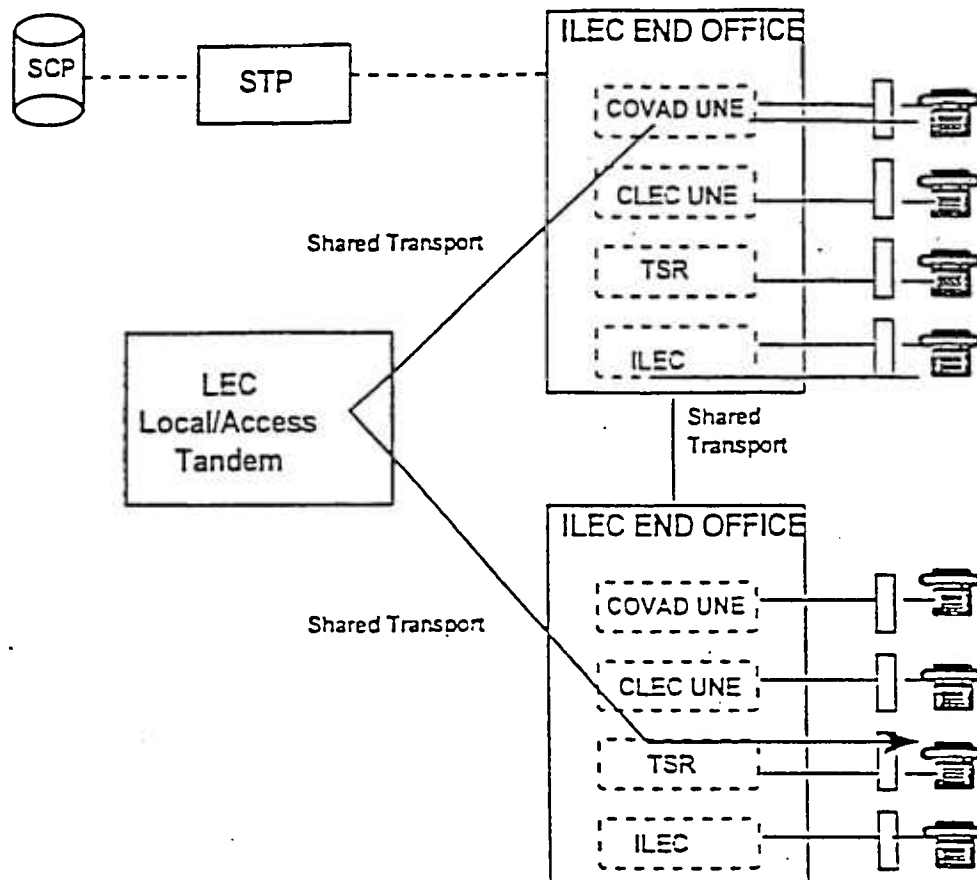

ILEC bills originating COVAD UNE for Local Switching Usage Charge, BELL ATLANTIC Shared Transport Charge, Reciprocal Compensation Charge and a Record Processing Charge. The Reciprocal compensation Charge is billed to the Originating COVAD UNE at the Meetpoint A rate. These charges apply regardless of the billing arrangements between COVAD UNE and TSR.

UNBUNDLED NETWORK ELEMENTS/FACILITY BASED NETWORK

When COVAD UNE provides local exchange service through UNE arrangements and another CLEC provides local exchange service through its facility based network (FBN), the call flows are as follows:

13. COVAD UNE Originating to CLEC (FBN) Terminating

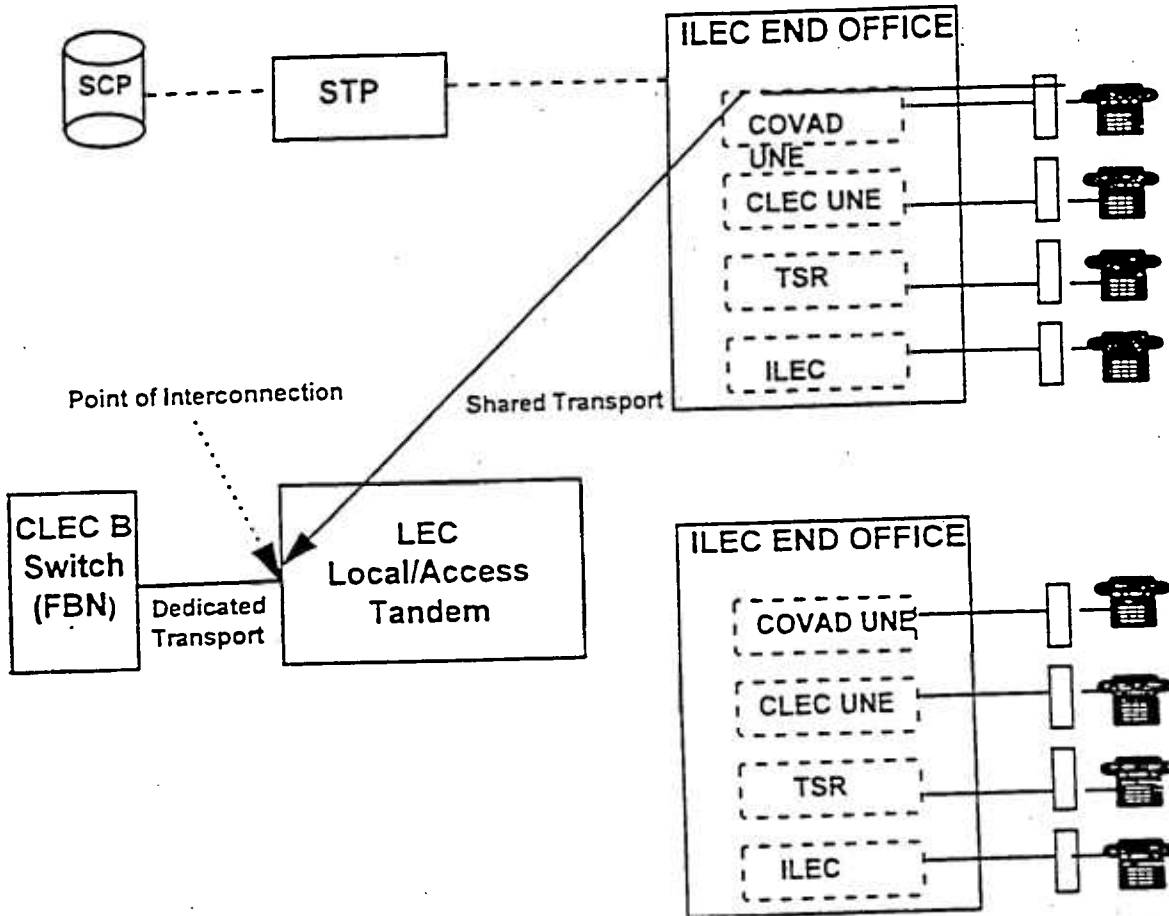

ILEC will bill originating COVAD UNE Local Switching Usage Charge, BELL ATLANTIC Shared Transport Charge, Co Carrier/FBN Charge at a blended rate (pass thru charge to the originating end, calculated in accordance with methodology set forth for transient tandem service in this Part IV and Attachment 6) and a Record Processing Charge. These charges apply regardless of any billing arrangements between COVAD UNE and CLEC B.

14. CLEC (FBN) Originating to COVAD UNE Terminating

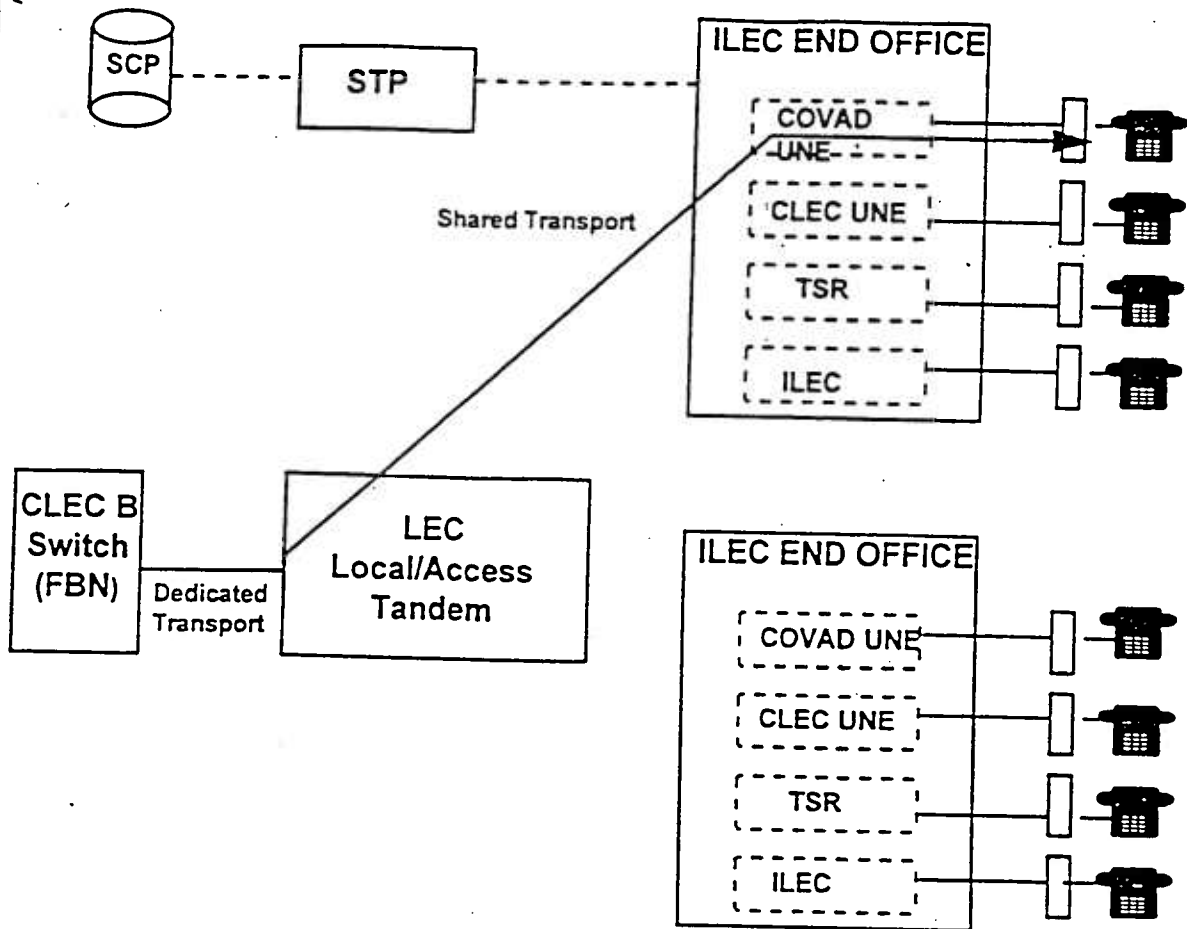

No charges shall apply to COVAD UNE. COVAD UNE shall not charge ILEC Reciprocal Compensation.

TOLL CALLS - INTRALATA

UNBUNDLED NETWORK ELEMENTS

When COVAD UNE provides local exchange service through UNE arrangements, the intraLATA call flows are as follows. These scenarios assume that the originating COVAD UNE is also the intraLATA toll provider:

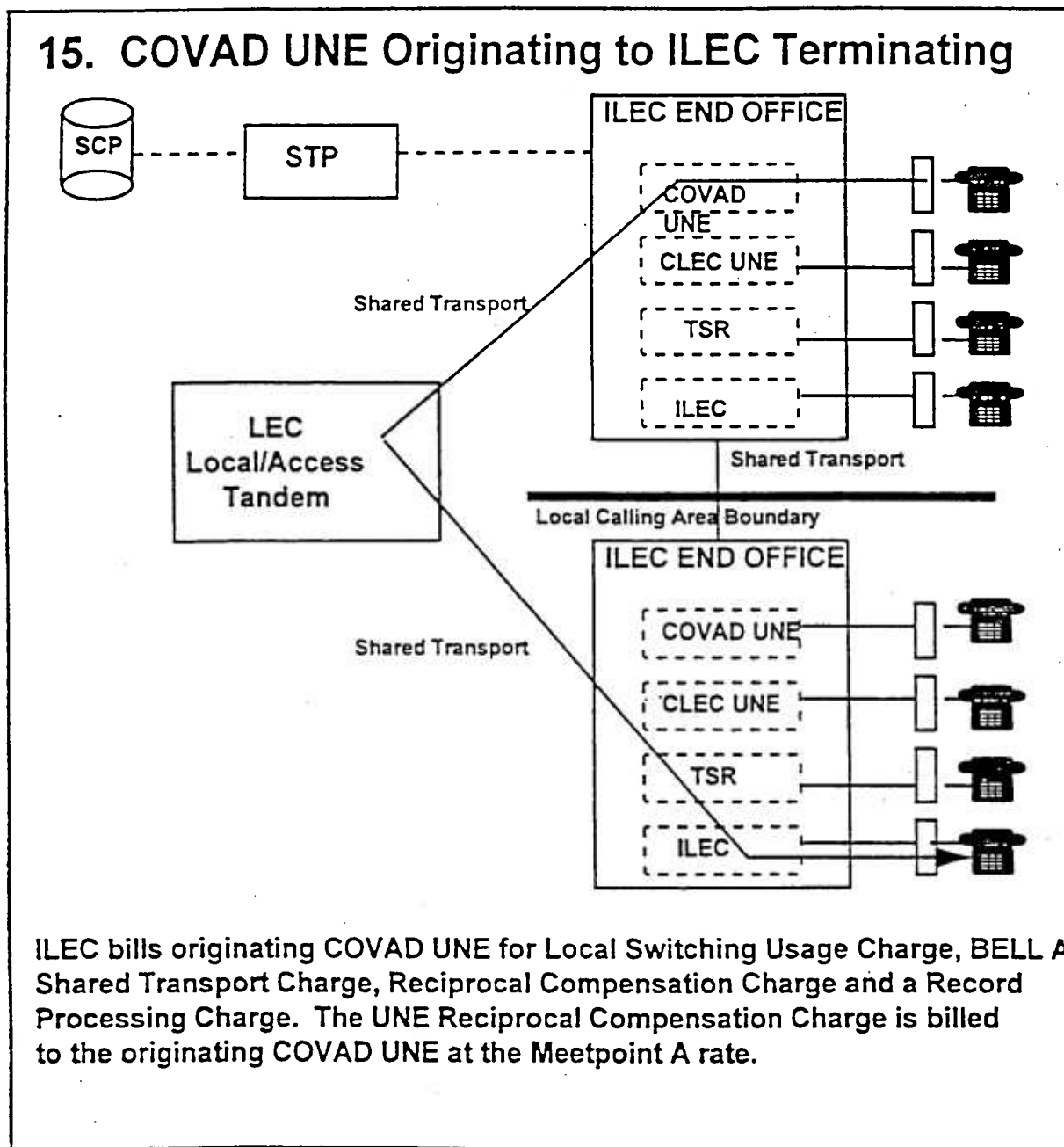

16. ILEC Originating to COVAD UNE Terminating

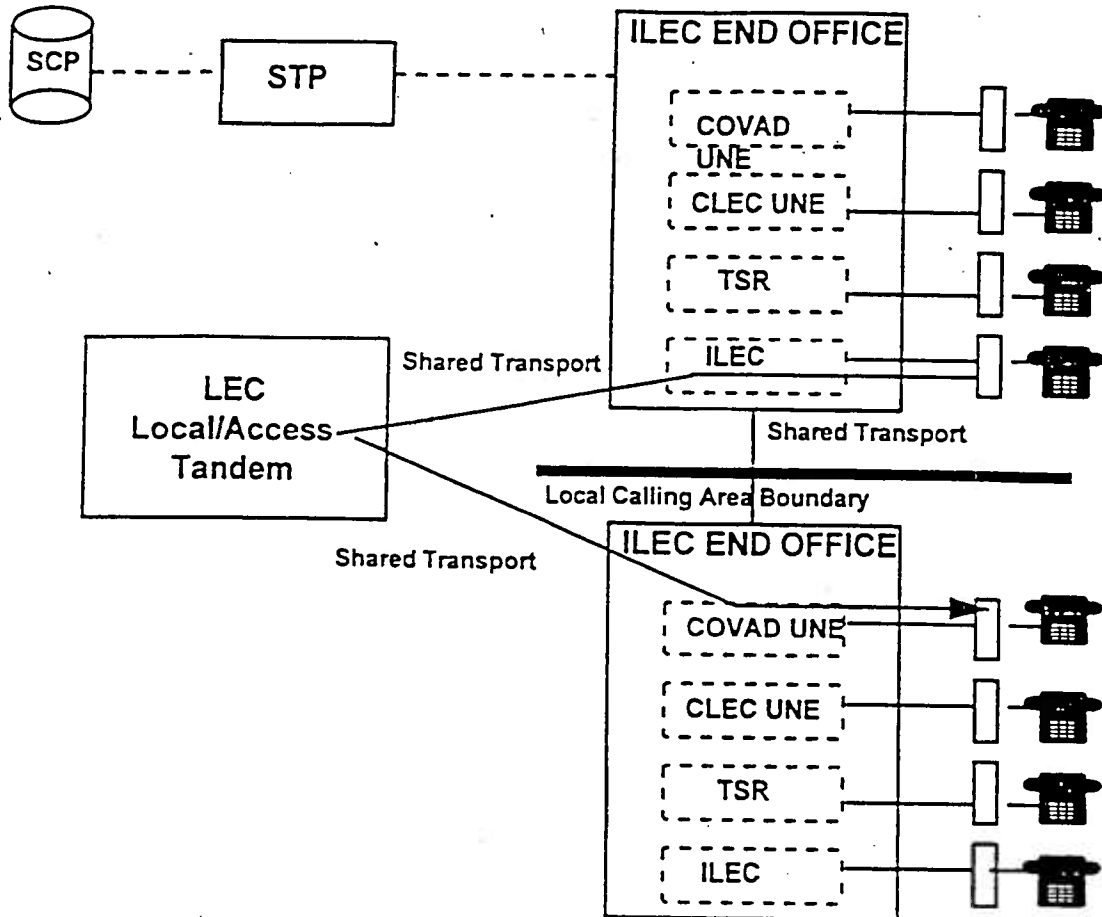

No usage charges apply to COVAD UNE. COVAD UNE shall not charge ILEC reciprocal compensation.

17. COVAD UNE Originating to CLEC UNE Terminating

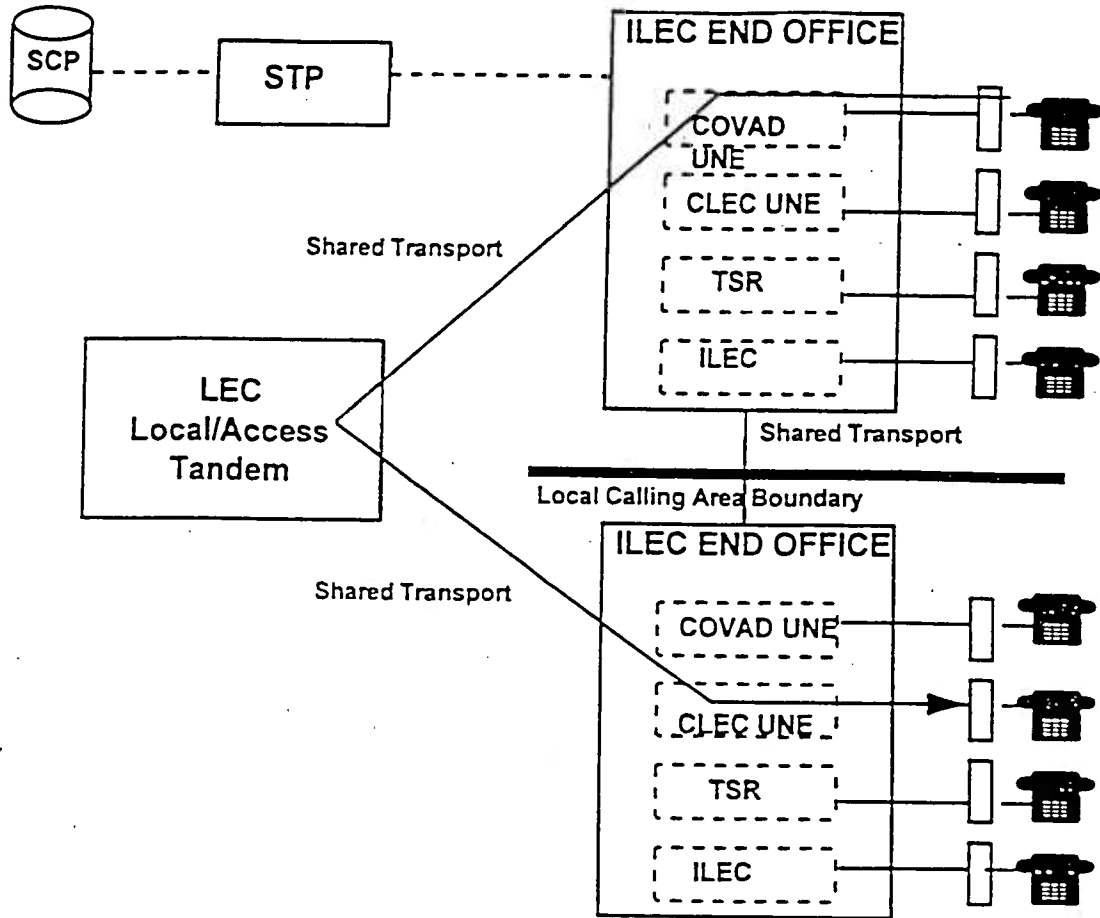

ILEC bills originating COVAD UNE for Local Switching Usage Charge, BELL ATLANTI Shared Transport Charge, Reciprocal Compensation Charge and a Record Processing Charge. The UNE Reciprocal Compensation Charge is billed to the originating COVAD UNE at the Meetpoint A rate. These charges apply regardless of any billing arrangements between COVAD UNE and CLEC UNE.

18. COVAD UNE Originating to COVAD UNE Terminating

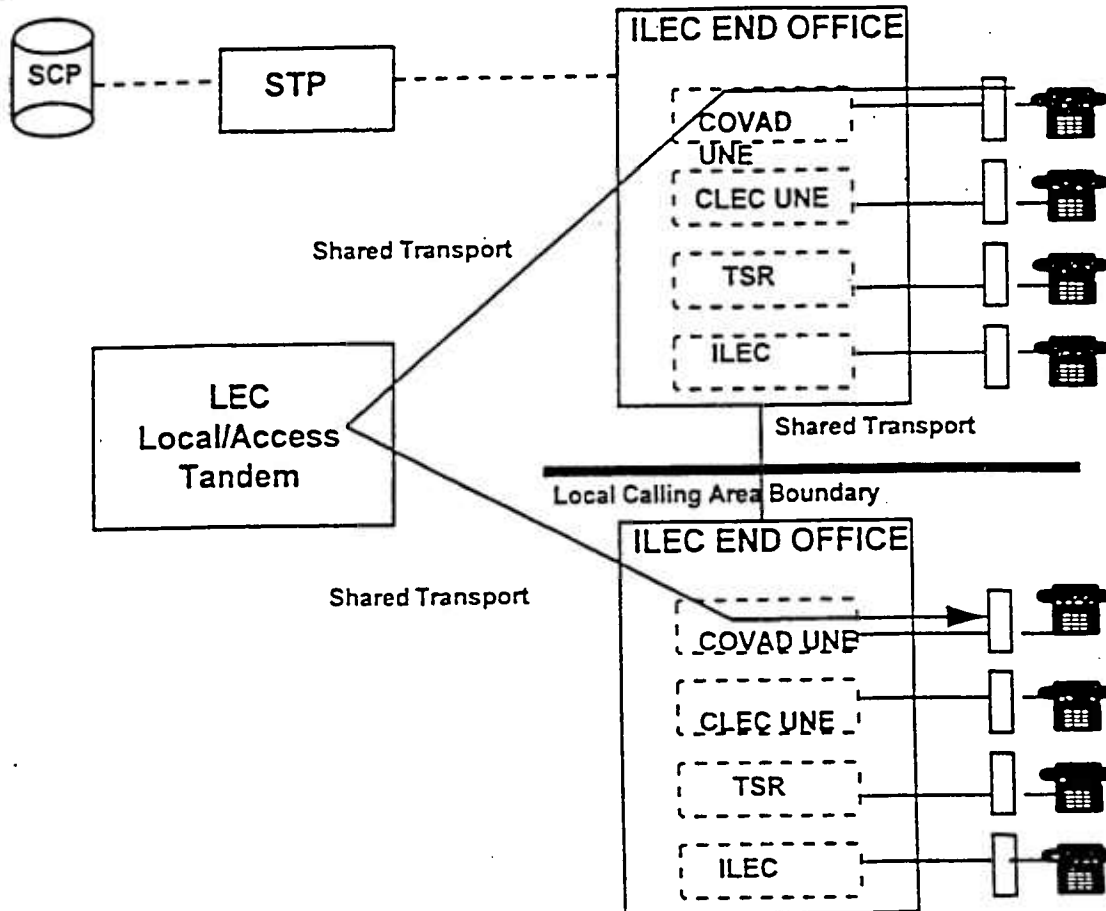

ILEC bills originating COVAD UNE for Local Switching Usage Charge, BELL ATLANTIC Shared Transport Charge, Reciprocal Compensation Charge and a Record Processing Charge. The UNE Reciprocal Compensation Charge is billed to the originating COVAD UNE at the Meetpoint A rate. Terminating COVAD UNE will not bill ILEC Reciprocal Compensation Charges.

UNBUNDLED NETWORK ELEMENTS/FACILITY BASED NETWORKS

When COVAD UNE provides local exchange service through UNE arrangements and another CLEC provides local exchange service through its facility based network, the call flows for intraLATA toll calls are as follows:

19. COVAD UNE Originating to CLEC (FBN) Terminating

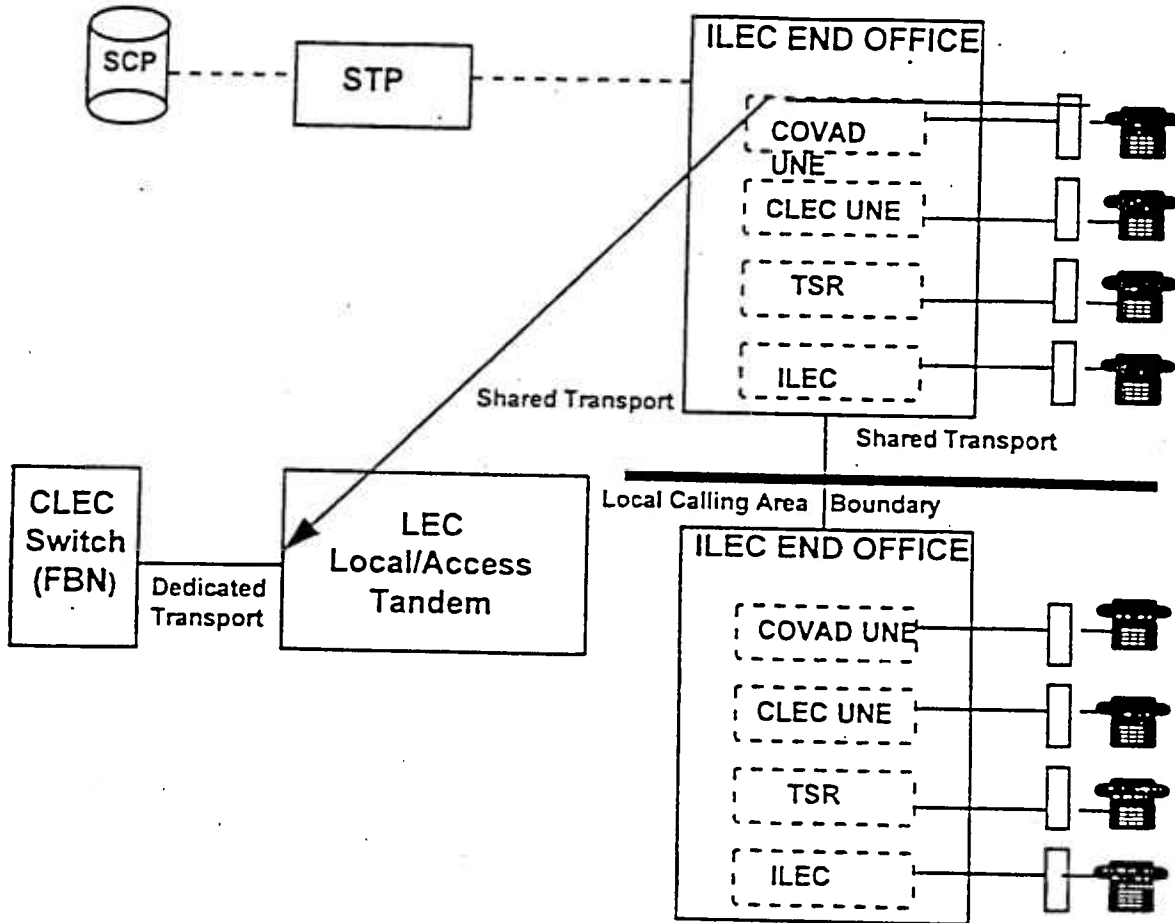

ILEC will bill originating COVAD UNE Local Switching Usage Charge, BELL ATLANTIC Shared Transport Charge, Co Carrier/FBN Charge at a blended rate (pass thru charge to the originating end calculated in accordance with methodology set forth for transient tandem service in this Part IV and in Attachment 6) and a Record Processing Charge. These charges apply regardless of any billing arrangements between COVAD UNE and CLEC.

20. CLEC (FBN) Originating to COVAD UNE Terminating

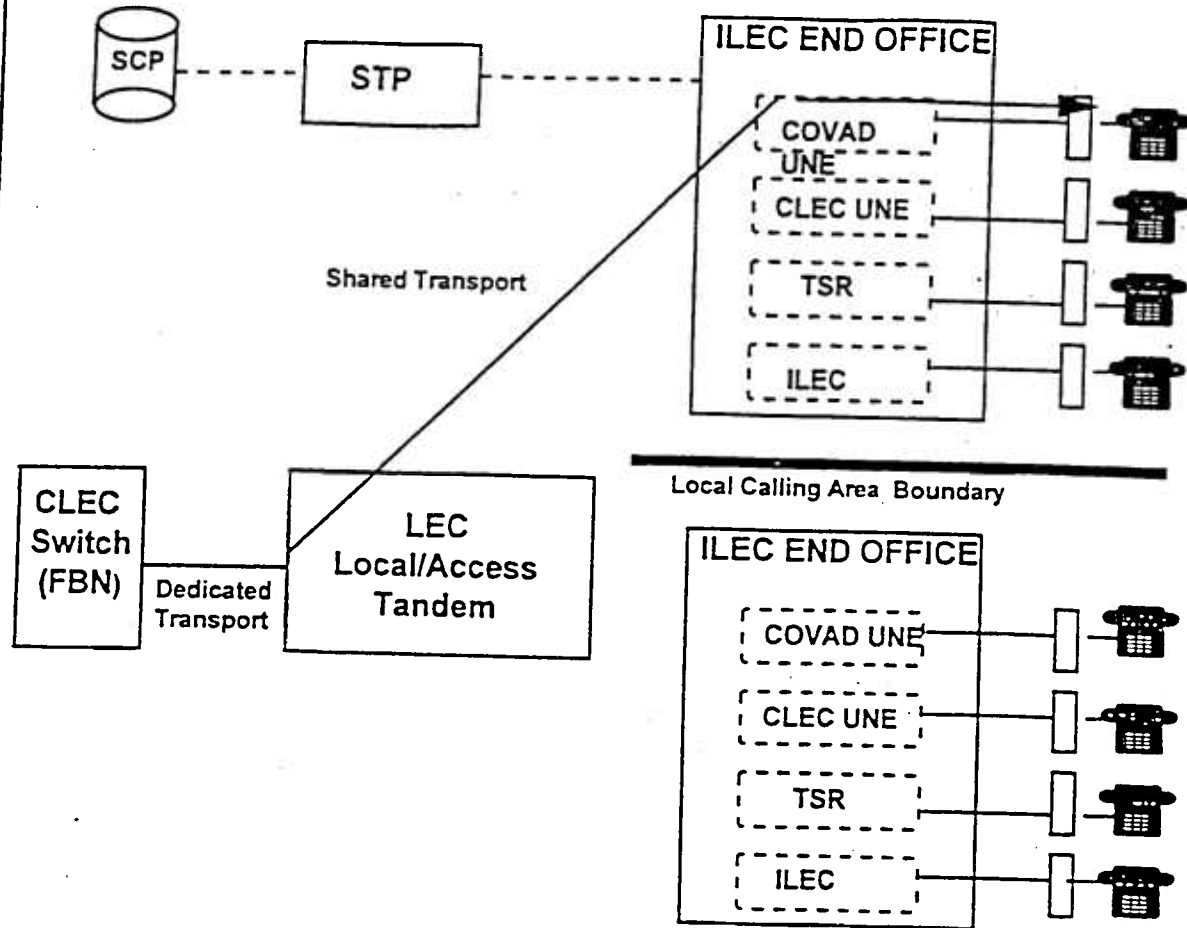

No charges shall apply to COVAD UNE. COVAD UNE shall not charge ILEC Reciprocal Compensation.

TOLL CALLS INTRASTATE/INTERLATA

The following call flows assume that all calls are routed to an IXC point of presence. The IXC may be the COVAD IXC or another, non-affiliated IXC.

UNBUNDLED NETWORK ELEMENTS

When a CLEC provides local exchange service through UNE arrangements, the call flows for intrastate/interLATA toll calls are as follows:

21. COVAD UNE Originating to COVAD's IXC

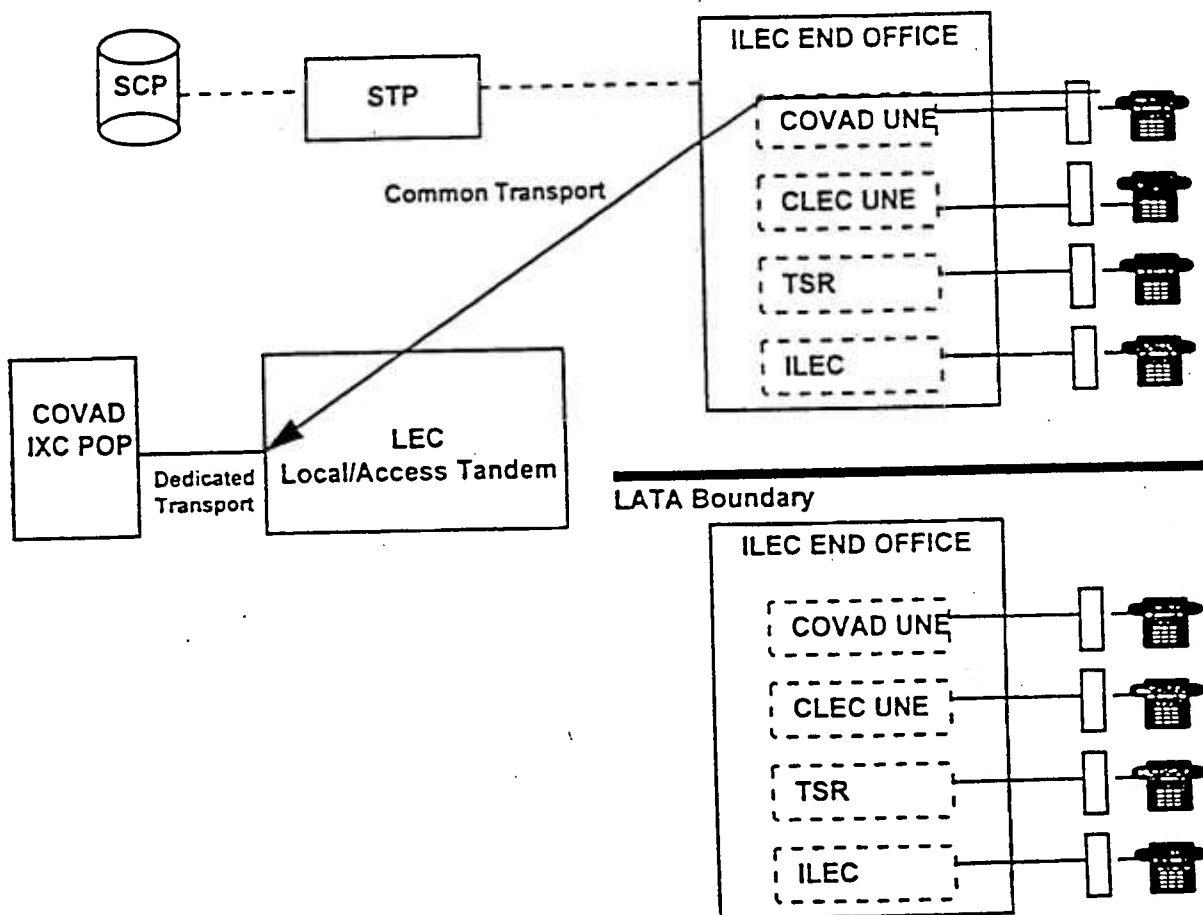

BELL ATLANTIC charges COVAD UNE one UNE local switching charge, common trunk usage, and a record processing charge. If IXC has usage based transport, UNE transport charges apply. If IXC has dedicated transport, no UNE transport charges apply. COVAD UNE bills access charges to IXC. The distribution of IXC access charge revenues is in accordance with Applicable Laws.

22. COVAD UNE Originating to a Non-Affiliated IXC

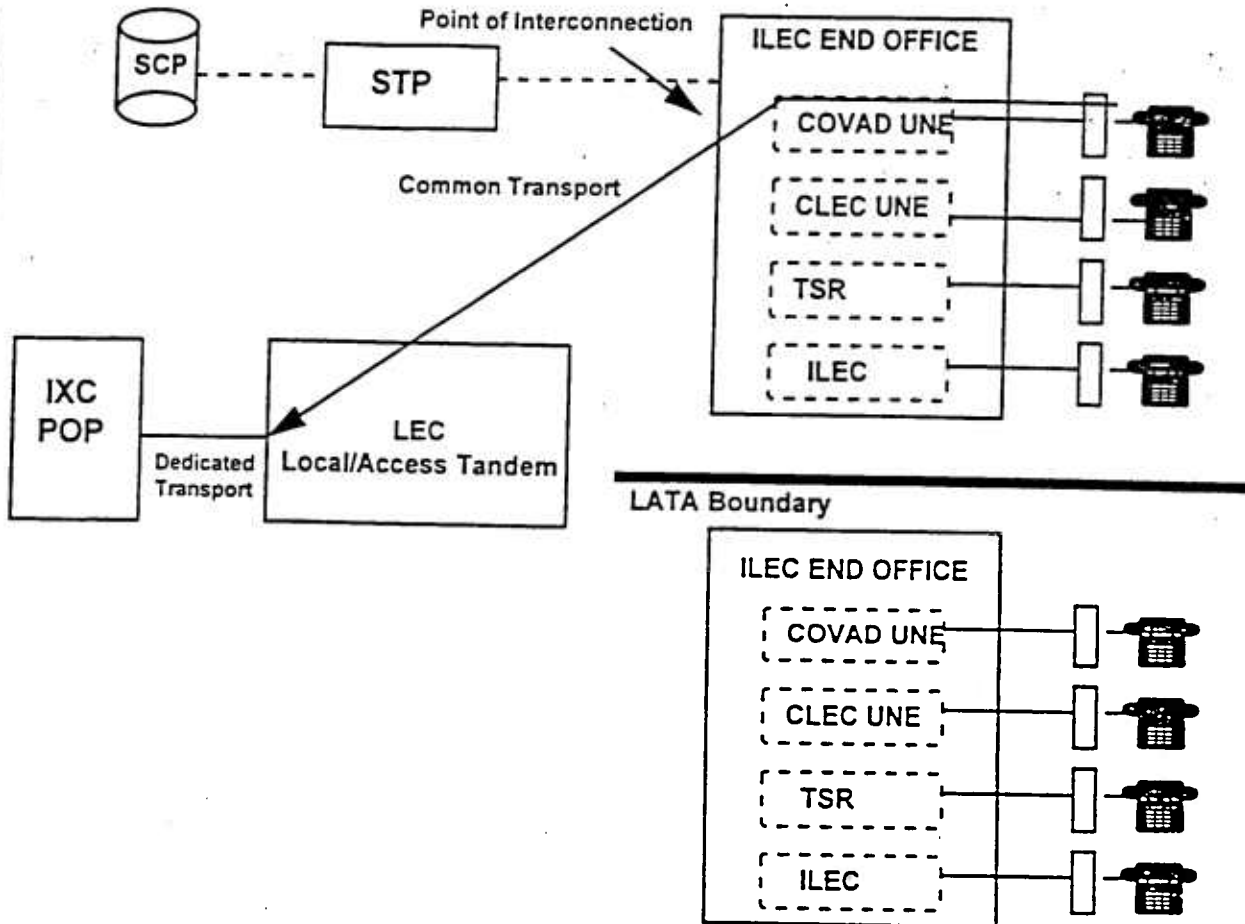

BELL ATLANTIC charges COVAD UNE one UNE local switching charge, common trunk usage, and a record processing charge. If IXC has usage based transport, UNE transport charges apply. If IXC has dedicated transport, no UNE transport charges apply. COVAD UNE bills access charges to IXC. The distribution of IXC access charge revenues is in accordance with Applicable Laws.

23. COVAD UNE Terminating from COVAD's IXC

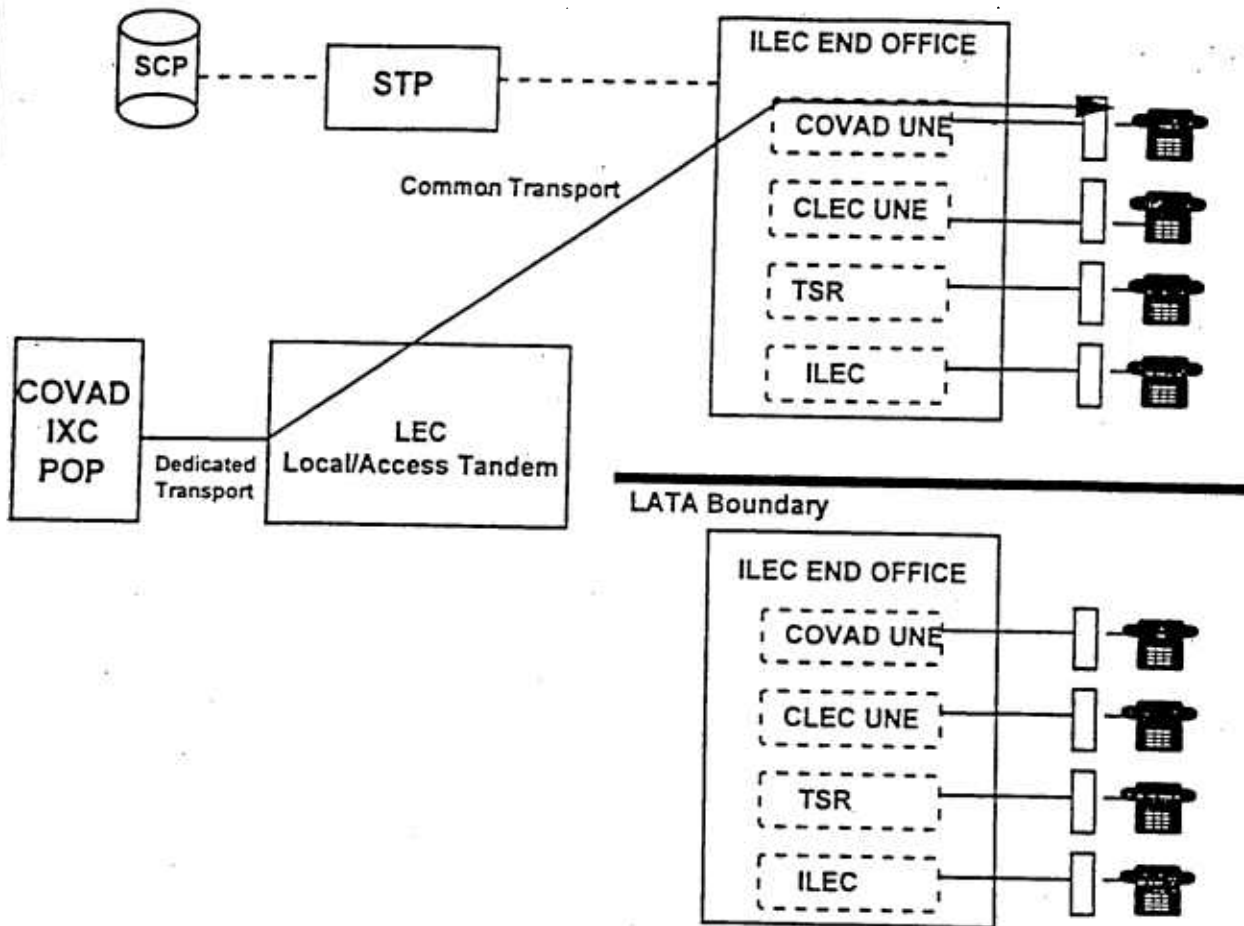

BELL ATLANTIC charges COVAD UNE one UNE local switching charge, common trunk usage, and a record processing charge. If IXC has usage based transport, UNE transport charges apply. If IXC has dedicated transport, no UNE transport charges apply. COVAD UNE bills access charges to IXC. The distribution of IXC access charge revenues is in accordance with Applicable Laws.

24. COVAD UNE Terminating from Non-Affiliated IXC

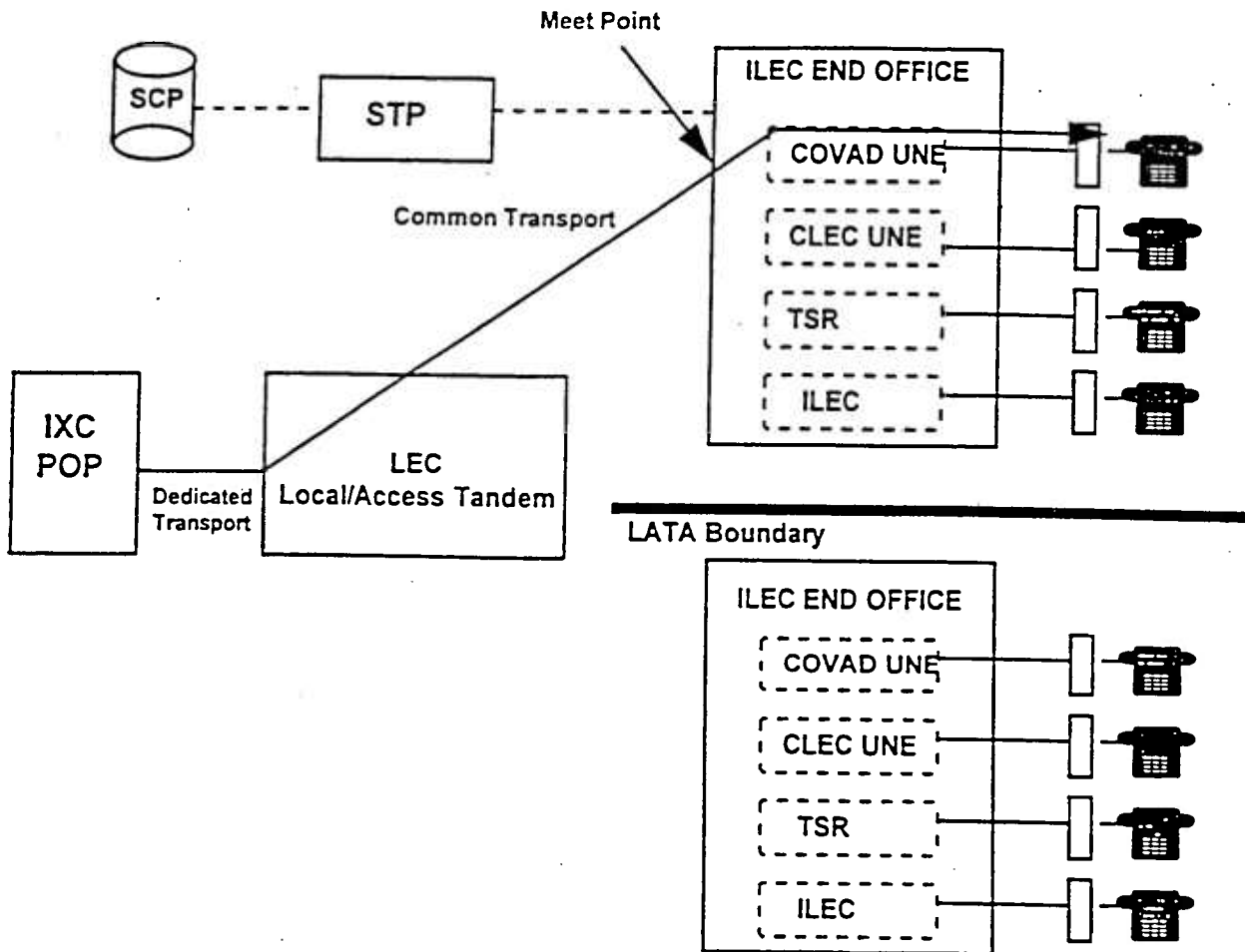

BELL ATLANTIC charges COVAD UNE one UNE local switching charge, common trunk usage, and a record processing charge. If IXC has usage based transport, UNE transport charges apply. If IXC has dedicated transport, no UNE transport charges apply. COVAD UNE bills access charges to IXC. The distribution of IXC access charge revenues is in accordance with Applicable Laws.

TOLL CALLS - INTERSTATE

The following call flows assume that all calls are routed to an IXC point of presence. The IXC may be the CLEC's own IXC or another, non-affiliated IXC.

UNBUNDLED NETWORK ELEMENTS

When a CLEC provides local exchange service through UNE arrangements, the call flows for interstate toll calls are as follows:

25. COVAD UNE Originating to COVAD's IXC

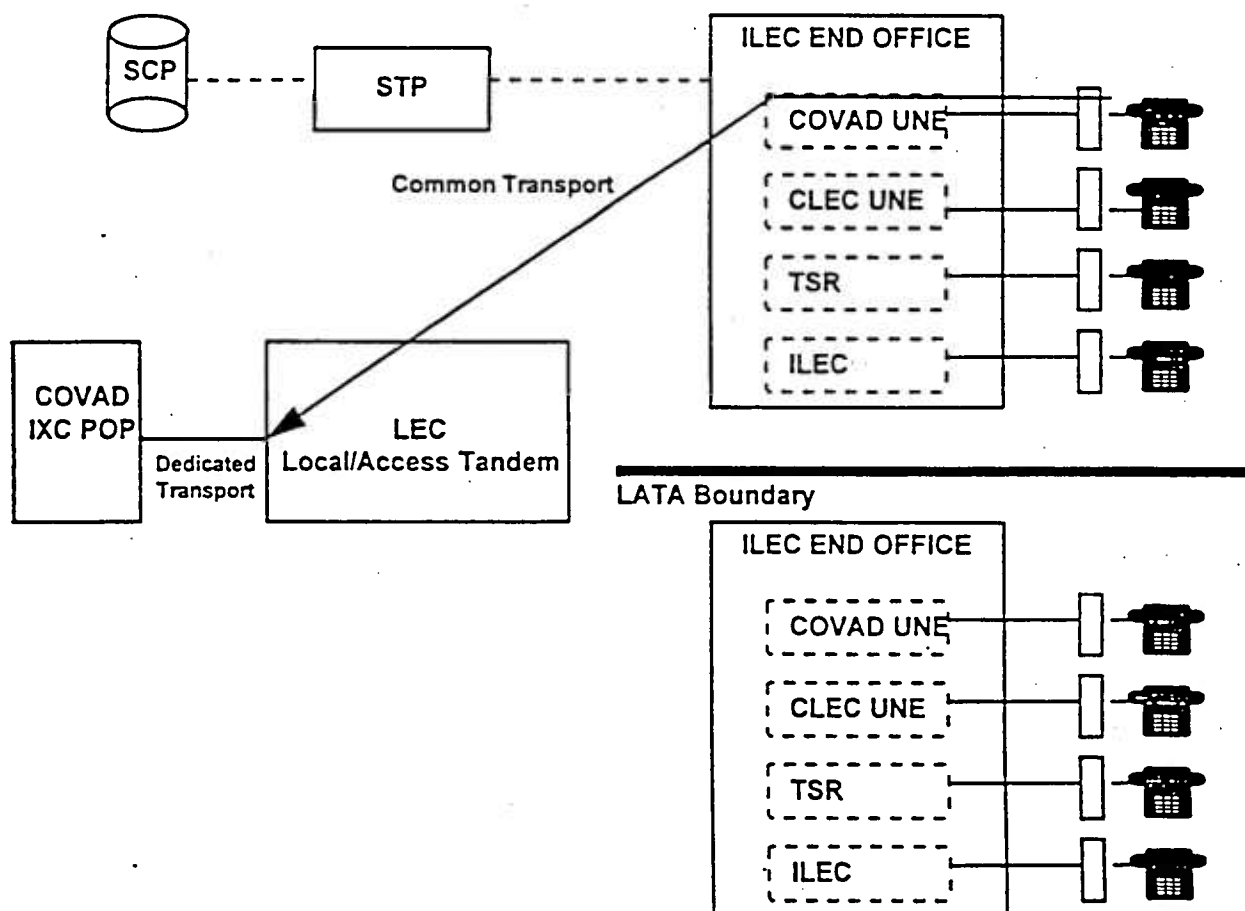

BELL ATLANTIC charges COVAD UNE one UNE local switching charge, common trunk usage, and a record processing charge. If IXC has usage based transport, UNE transport charges apply. If IXC has dedicated transport, no UNE transport charges apply. COVAD UNE bills access charges to IXC. The distribution of IXC access charge revenues is in accordance with Applicable Laws.

26. COVAD UNE Originating to a Non-Affiliated IXC

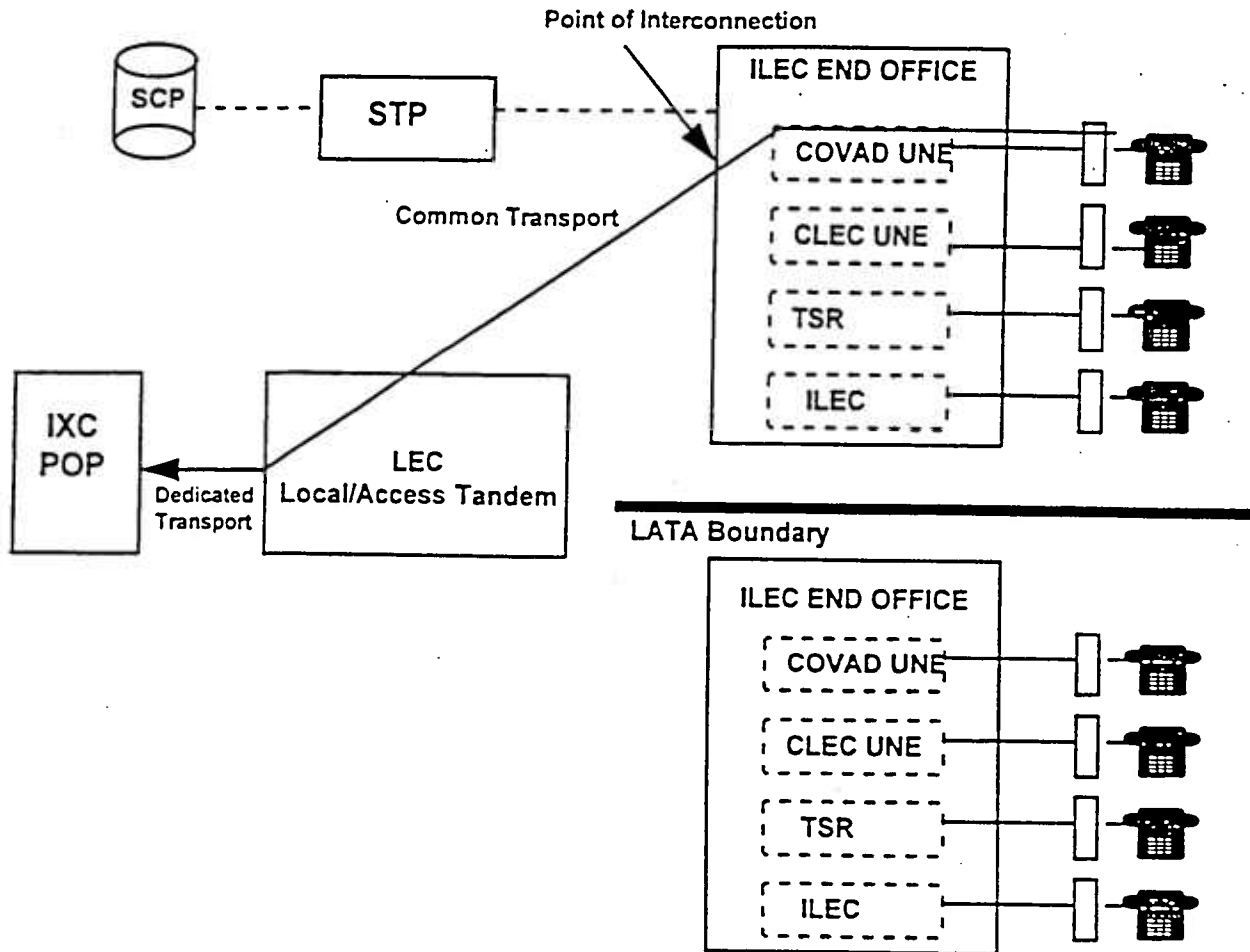

BELL ATLANTIC charges COVAD UNE one UNE local switching charge, common trunk usage, and a record processing charge. If IXC has usage based transport, UNE transport charges apply. If IXC has dedicated transport, no UNE transport charges apply. COVAD UNE bills access charges to IXC. The distribution of IXC access charge revenues is in accordance with Applicable Laws.

27. COVAD UNE Terminating from COVAD's IXC

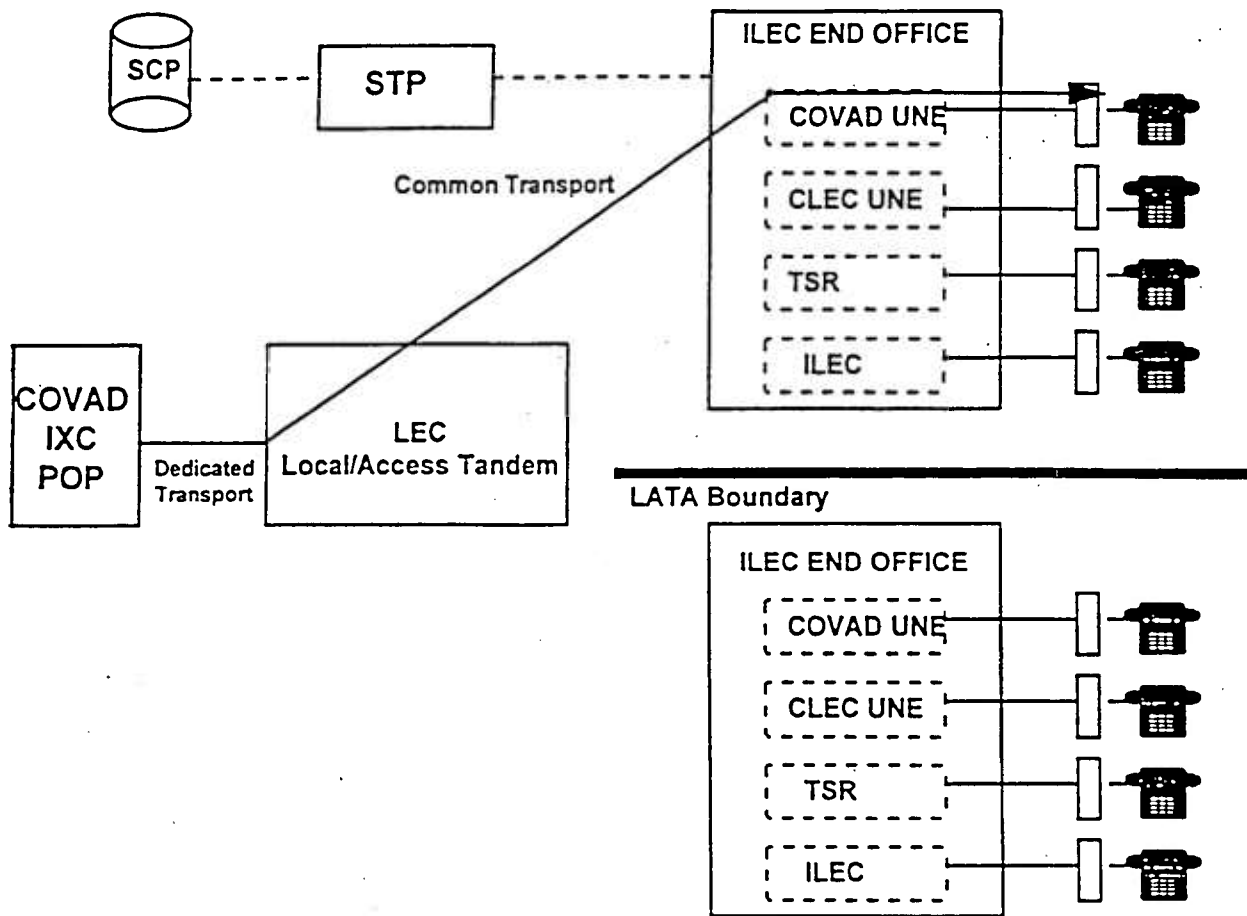

BELL ATLANTIC charges COVAD UNE one UNE local switching charge, common trunk usage, and a record processing charge. If IXC has usage based transport, UNE transport charges apply. If IXC has dedicated transport, no UNE transport charges apply. COVAD UNE bills access charges to IXC. The distribution of IXC access charge revenues is in accordance with Applicable Laws.

28. COVAD UNE Terminating from Non-Affiliated IXC

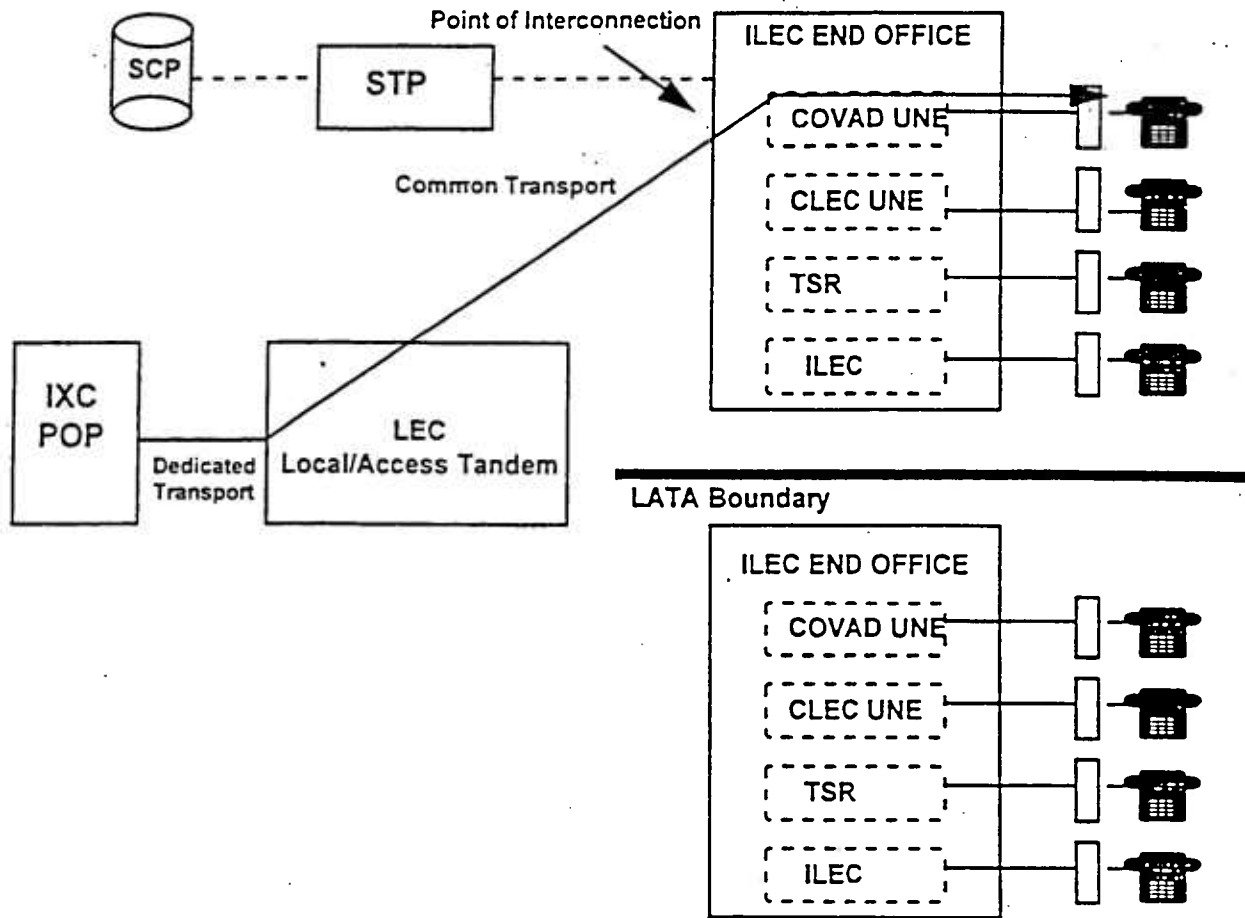

BELL ATLANTIC charges COVAD UNE one UNE local switching charge, common trunk usage, and a record processing charge. If IXC has usage based transport, UNE transport charges apply. If IXC has dedicated transport, no UNE transport charges apply. COVAD UNE bills access charges to IXC. The distribution of IXC access charge revenues is in accordance with Applicable Laws.

LOCAL 800 CALLS

29. COVAD UNE Originating and ILEC Terminating Local 800 Service

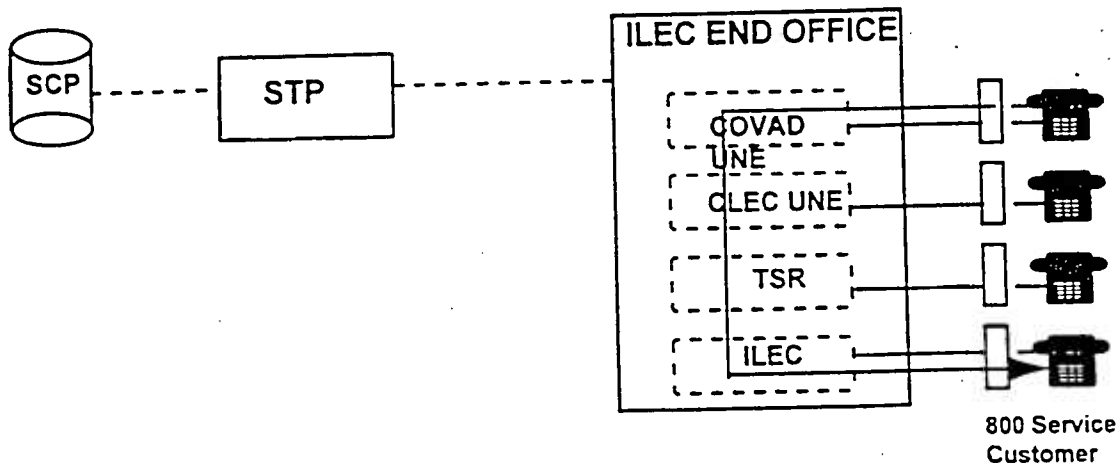

No usage charges apply to COVAD UNE.

30. ILEC Originating and COVAD UNE Terminating Local 800 Service

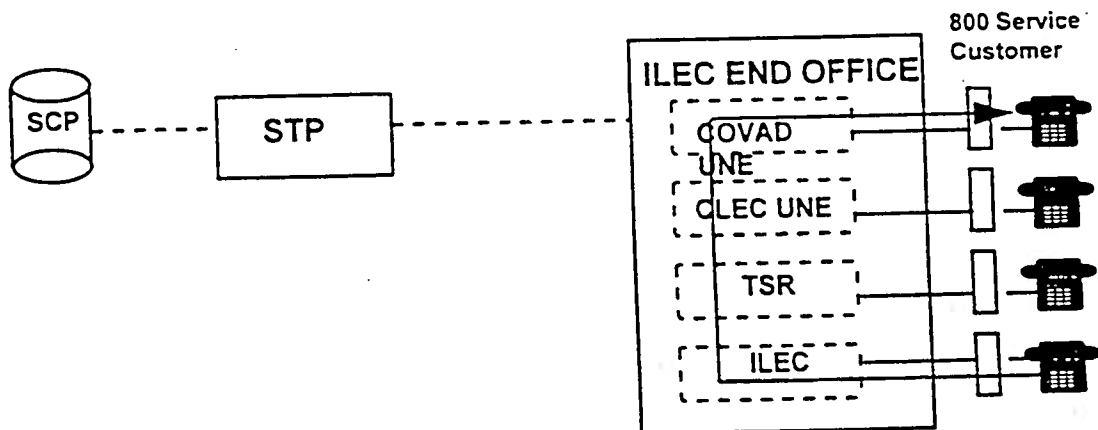

ILEC bills terminating COVAD UNE two Local Switching Usage Charges, 800 Database Query Charge and a Record Processing Charge.

31. COVAD UNE Originating and ILEC Terminating Local 800 Service

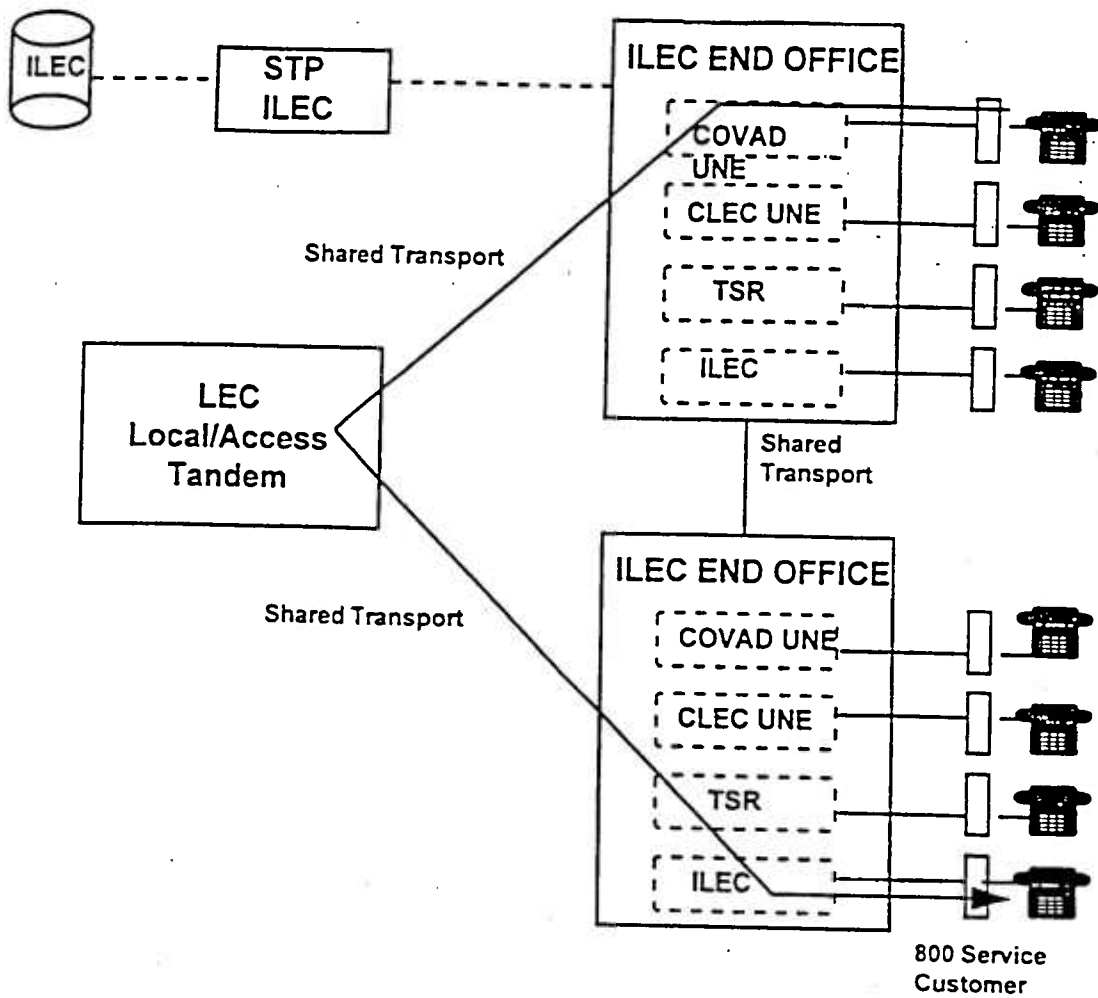

No usage charges apply to COVAD UNE. COVAD UNE shall not charge ILEC Reciprocal Compensation.

32. ILEC Originating and COVAD UNE Terminating Local 800

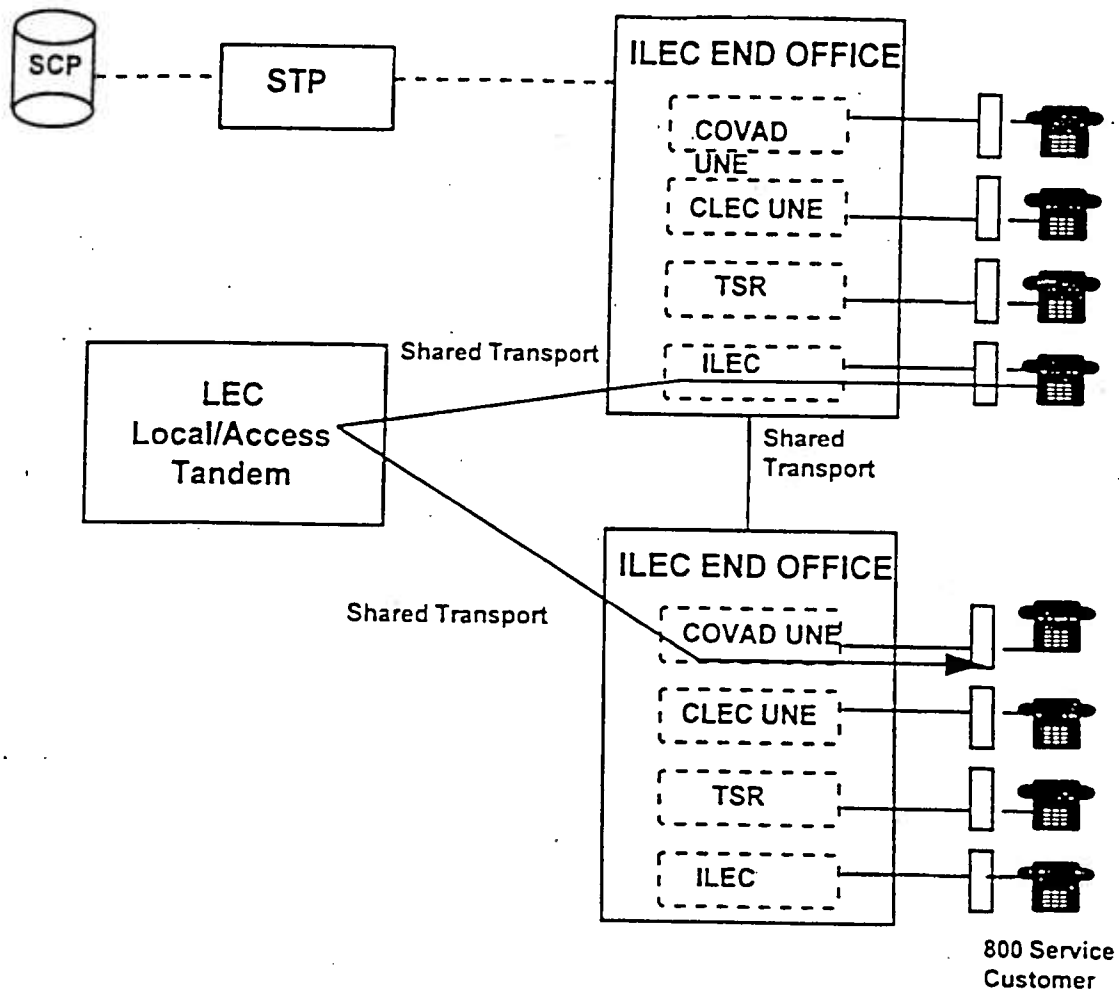

ILEC bills terminating COVAD UNE Local Switching Usage Charge, BELL ATLANTIC Shared Transport Charge, Reciprocal Compensation Charge, 800 Database Query Charge and a Record Processing Charge. Reciprocal Compensation Charge is billed to terminating COVAD UNE at the Meetpoint A rate.

PART V: INTERCONNECTION

Except for Reciprocal Compensation arrangements which shall be determined exclusively by the terms and conditions of this Agreement, BELL ATLANTIC shall provide COVAD with interconnection services pursuant to the N.Y. P.S.C. No. 914 Tariff, as amended from time to time. The Parties shall compensate each other for transport and termination of Reciprocal Compensation Traffic in an equal and symmetrical manner at the rates provided in Part IV.

ATTACHMENT 1: DEFINITIONS

Definitions

"AAA" means American Arbitration Association.

"Act" or "Telecommunications Act" means the Communications Act of 1934 (47 U.S.C. 153(R)), as amended by the Telecommunications Act of 1996, and as from time to time interpreted in the duly authorized rules and regulations of the FCC or a Commission within its state of jurisdiction.

"Asymmetrical Digital Subscriber Line" means a transmission technology which transmits an asymmetrical digital signal using one of a variety of line codes as specified in ANSI standards T1.413-1995-007R2.

"As Defined in the Act" means as specifically defined by the Act and as from time to time interpreted in the duly authorized rules and regulations of the FCC or the Commission.

"As Described in the Act" means as described in or required by the Act and as from time to time interpreted in the duly authorized rules and regulations of the FCC or the Commission.

"Automatic Number Identification" means a Feature Group D signaling parameter which refers to the number transmitted through a network identifying the billing number of the calling party.

"Branding" means the initial identification by the BELL ATLANTIC OSDAS automated system responding to a COVAD end-user call, of the local service provider for such end user. Additionally, BELL ATLANTIC operators or automated systems shall not provide any conflicting brand for such OSDAS calls.

"BRI-ISDN" means 2-Wire ISDN-Compatible Digital Loop.

"Calling Party Number" is a Common Channel Interoffice Signaling ("CCIS") parameter which refers to the number transmitted through a network identifying the calling party.

"CCS" means one hundred (100) call seconds.

"Central Office Switch" means a switch used to provide Telecommunications Services, including, but not limited to:

(a) "End Office Switches" which are used to terminate Customer station Links for the purpose of interconnection to each other and to trunks; and

(b) "Tandem Office Switches" which are used to connect and switch trunk circuits between and among other Central Office Switches.

A Central Office Switch may also be employed as a combination End Office/Tandem Office Switch.

"CLASS features" means certain CCIS-based features available to Customers including, but not limited to: Automatic Call Back; Call Trace; Caller Identification; Call Return and future CCIS-based offerings.

"Commission" or "PSC" means the New York Public Service Commission.

"Common Channel Interoffice Signaling" means the signaling system, developed for use between switching systems with stored-program control, in which all of the signaling information for one or more groups of trunks is transmitted over a dedicated high-speed data link rather than on a per-trunk basis and, unless otherwise agreed by the Parties, the CCIS used by the Parties shall be SS7.

"Cross Connection" means a connection provided at the digital signal cross connect, Main Distribution Frame or other suitable frame or panel to another suitable frame, panel or piece of equipment.

"Customer" means a third-party residence or business end user subscribing to Telecommunications Services provided by either of the Parties.

M:\Kw24778\Covad\Covadny4.Doc

"Digital Signal Level" means one of several transmission rates in the time-division multiplex hierarchy.

"Digital Signal Level 0" or "DS0" means the 64 Kbps zero-level signal in the time-division multiplex hierarchy.

"Digital Signal Level 1" or "DS1" means the 1.544 Mbps first-level signal in the time-division multiplex hierarchy. In the time-division multiplexing hierarchy of the telephone network, DS1 is the initial level of multiplexing.

"Digital Signal Level 3" or "DS3" means the 44.736 Mbps third-level in the time-division multiplex hierarchy. In the time-division multiplexing hierarchy of the telephone network, DS3 is defined as the third level of multiplexing.

"Direct Customer Access Service" is an electronic interface system provided by BELL ATLANTIC to facilitate the ordering, provisioning and maintenance of various interconnection arrangements.

"Exchange Access" is As Defined in the Act.

"Exchange Message Record" means the standard used for exchange of Telecommunications message information among Telecommunications providers for billable, nonbillable, sample, settlement and study data. EMR format is contained in Bellcore Practice BR-010-200-010 CRIS Exchange Message Record.

"Fiber-Meet" means an Interconnection architecture method whereby the Parties physically Interconnect their networks via an optical fiber interface (as opposed to an electrical interface) at a mutually agreed upon location.

"High-Bit Rate Digital Subscriber Line" means a transmission technology which transmits up to a DS1-level signal, using any one of the following line codes: 2 Binary / 1 Quaternary ("2B1Q"), Carrierless AM/PM, Discrete Multitone ("DMT"), or 3 Binary / 1 Octel ("3B1O").

"Information Service Traffic" means Local Traffic or IntraLATA Toll Traffic which originates on a Telephone Exchange Service line and which is addressed to an information service provided over a Party's information services platform (e.g., 976).

"Integrated Services Digital Network" means a switched network service that provides end-to-end digital connectivity for the simultaneous transmission of voice and data. Basic Rate Interface-ISDN ("BRI-ISDN") provides for a digital transmission of two 64 kbps bearer channels and one 16 kbps data channel ("2B+D").

"Loss" or "Losses" means any and all losses, costs (including court costs), claims, damages (including fines, penalties, and criminal or civil judgments and settlements), injuries, liabilities and expenses (including attorneys' fees).

"Main Distribution Frame" means the distribution frame of the Party providing the Link (or Loop) used to interconnect cable pairs and line and trunk equipment terminals on a switching system.

"Numbering Plan Area" means the 3-digit code which occupies the A, B, C positions in the 10-digit NANP format which applies throughout NANP area. NPAs are in the form of "NXX," where N is the number from 2 to 9 and X is a number from 0 to 9. In the NANP, NPAs are classified as either geographic or non-geographic. The common examples are NPAs in the N00 format, e.g., 800. N00 codes are commonly referred to as service access codes (SACs).

"NXX" means the three-digit code which appears as the first three digits of a seven digit telephone number.

"Point of Termination Bay" means the intermediate distributing frame system which serves as the point of demarcation for collocated interconnection.

"Public Service Answering Point" means an answering location for 911 calls originating in a given area. A PSAP may be designated as Primary or Secondary, which refers to the order in which calls are directed for answering. Primary PSAPs respond first; Secondary PSAPs receive calls on a transfer basis only, and generally serve as a centralized answering location for a particular type of emergency call. PSAPs are staffed by employees of Service Agencies such as police, fire or emergency medical agencies or by employees of a common bureau serving a group of such entities.

"Rate Center" means the specific geographic point which has been designated by a given LEC as being associated with a particular NPA-NXX code which has been assigned to the LEC for its provision of Telephone Exchange Service. The Rate Center is the finite geographic point identified by a specific V&H coordinate, which is used by that LEC to measure, for billing purposes, distance-sensitive transmission services associated with the specific Rate Center.

"Reciprocal Compensation" is As Described in the Act, and refers to the payment arrangements that recover costs incurred for the transport and termination of Telephone Exchange Service Traffic.

"Reciprocal Compensation Call" or "Reciprocal Compensation Traffic" means a Telephone Exchange Service Call completed between the Parties, which qualifies for Reciprocal Compensation pursuant to the terms of this Agreement and prevailing Commission or FCC rules that may exist, except that ISP Traffic is not a Reciprocal Compensation Call or Reciprocal Compensation Traffic.

"Switched Exchange Access Service" means the offering of transmission or switching services to Telecommunications Carriers for the purpose of the origination or termination of Telephone Toll Service.

"Synchronous Optical Network" means an optical interface standard that allows inter-networking of transmission products from multiple vendors. The base rate is 51.84 Mbps ("OC-1/STS-1") and higher rates are direct multiples of the base rate, up to 13.22 Gpbs.

"Telecommunications" is As Defined in the Act.

"Telecommunications Carrier" is As Defined in the Act.

"Telecommunications Service" is As Defined in the Act.

"Telephone Exchange Service" is As Defined in the Act.

"Telephone Exchange Service Call" or "Telephone Exchange Service Traffic" means a call completed between two Telephone Exchange Service Customers of the Parties located in the same LATA in the State of New York, originated on one Party's network (including COVAD's use of unbundled switching) and terminated on the other Party's facilities-based network where such call was not carried by a third party as either a presubscribed call (1+) or a casual dialed (10XXX or 101XXXX) call, and where such call is not ISP Traffic.

"Telephone Relay" means a service provided to speech and/or hearing-impaired callers that enables such callers to type a message into a telephone set equipped with a keypad and message screen and to have a live operator read the message to a

recipient and to type recipient's response message to the speech or hearing-impaired caller.

Acronyms

"ACD" means Automatic Call Distributor.
"ADSL" means Asymmetrical Digital Subscriber Line.
"AIN" means Advanced Intelligent Network.
"ANI" means Automatic Number Identification.
"BACR" means billing account cross reference.
"BAR" means billing account reference.
"BDFB" means Battery Distribution Fuse Bay.
"BLV" means Busy Line Verification.
"BLVI" means Busy Line Verification and Interrupt.
"CABS" means Carrier Access Billing System.
"CPN" means Calling Party Number.
"CIC" means carrier identification code.
"CCIS" means Common Channel Interoffice Signaling.
"CCL" means common carrier line.
"COS" means class of service.
"DCAS" means Direct Customer Access Service.
"EBCDIC" means extended binary-coded decimal interchange code.
"ECSRRS" means Electronic Customer Service Record Retrieval Service.
"EFT" means electronic funds transfer.
"EMR" means Exchange Message Record.
"HDSL" means High-Bit Rate Digital Subscriber Line.
"INP" means Interim Number Portability.
"ISDN" means Integrated Services Digital Network.
"JPPPs" means Independent Public Payphone Providers.
"ISDN" means Integrated Services Digital Network.
"IXC" means Interexchange Carrier.
"LATA" means Local Access and Transport Area.
"LEC" means Local Exchange Carrier.
"LERG" means Local Exchange Routing Guide.
"LIDB" means Line Information Database.

M:\Kw24778\Covad\Covadny4.Doc

"LSO" means Local Serving Office.
"MDF" means Main Distribution Frame.
"MECAB" means Multiple Exchange Carrier Access Billing.
"MECOD" means Multiple Exchange Carriers Ordering and Design.
"MLT" means Mechanized Loop Testing.
"MPB" means meet-point billing.
"NECA" means National Exchange Carrier Association.
"NID" means Network Interface Device.
"NPA" means Numbering Plan Area.
"OBF" means the Ordering and Billing Forum.
"OSDAS" means Operator Services and Directory Assistance Services.
"OSHA" means the Occupational Safety and Health Act.
"OSS" means Operations Support Systems.
"PAL" means Public Access Line.
"POT Bay" means Point of Termination Bay.
"PSAP" means Public Service Answering Point.
"RIC" means residual interconnection charges.
"RLM" means Remote Line Module.
"ROW" means rights of way.
"RSM" means Remote Switching Module.
"SCP" means Service Control Point.
"SMS" means Service Management Systems.
"SONET" means Synchronous Optical Network.
"SPOC" means single point of contact.
"SPOI" means Signaling Points of Interconnection.
"STP" means Signaling Transfer Points.
"TSR" means total service resale.
"WTNs" means working telephone numbers.

ATTACHMENT 2 - OPERATIONS PLAN & IMPLEMENTATION TEAM

The Parties understand that the arrangements and the provision of services described in this Agreement shall require technical and operational cooperation between the Parties. Accordingly, the Parties shall jointly develop a plan (the "Operations Plan") which shall further define and detail the processes to be used by the parties in the areas of (1) provisioning and ordering (including pre order), (2) maintenance, repair and testing, (3) billing and recording, (4) provision of customer usage data, and (5) network security. The Operations Plan will include, among other things, provisions concerning the following:

- (a) agreement on physical architecture for the interconnection of the Parties' networks;
- (b) the respective duties and responsibilities of the Parties with respect to the administration and maintenance of interconnection trunk groups, including but not limited to standards and procedures for notification and discoveries of trunk disconnects;
- (c) disaster recovery provision escalations;
- (d) access to all necessary OSS functions, including interfaces and gateways;
- (e) procedures that specify the requisite time period(s) in which BELL ATLANTIC shall give COVAD notice and the applicable information and specifications regarding any changes to interfaces of the OSS functions;
- (f) escalation procedures for provisioning and maintenance;
- (g) single points of contact for provisioning and maintenance;
- (h) service ordering and provisioning procedures, including provision of the trunks and facilities;
- (i) provisioning and maintenance support;
- (j) conditioning of collocation spaces;

- (k) joint engineering and design requirements for high usage situations, including End Office to End Office trunks.
- (l) procedures and processes for Directories and Directory Listings;
- (m) service referral procedures, including procedures for handling misdirected inquiries and calls and procedures for handling out-of-service or irate Customers;
- (n) training;
- (o) billing, including measurements, rating and validation process;
- (p) network planning components, including system architecture, planning SONET equipment configuration, fiber hand-off, test and acceptances of SONET ring, trunking, signaling, interface points, and augment process;
- (q) joint systems readiness and operational readiness plans;
- (r) security;
- (s) [intentionally omitted]
- (t) such other matters as the Parties may agree.
- (u) single point of contact for collocation spaces.

The Operations Plan shall provide that operational interfaces will be capable of supporting orders for all unbundled Network Elements specified in this Agreement. The initial mutual interconnection of the Parties' networks, and the provision of unbundled Network Elements, collocation and other services covered by this Agreement, is not dependent upon completion of the Operations Plan.

Implementation Team.

The Parties agree to form a team (the "Implementation Team") which shall

develop and identify those processes, guidelines, specifications, and standards to be followed in the provision of the services covered by this Agreement and the specific implementation obligations of each Party. Within thirty (30) days after the Effective Date of this Agreement or as mutually agreed to by both parties, each Party shall designate those persons to be members of the Implementation Team. Those persons designated by each of the Parties shall only be persons with technical or operational responsibilities for implementation of this Agreement. At their option, the Parties may establish such other working groups as they may designate. The processes described herein and the agreements reached by the Parties in the Implementation Plan shall not relieve either Party of any obligations imposed by law.

Implementation Plan.

Within four (4) months after the Effective Date or as mutually agreed to by both parties, the Implementation Team shall reach agreement on items to be included in the Implementation Plan, which shall include (i) processes, procedures, and milestone agreements, (ii) documentation of the various items described in this Agreement which are to be included in the Implementation Plan, including the matters specified above, and (iii) any other matters agreed upon by the Implementation Team.

Action of Implementation Teams.

The Implementation Plan may be modified from time to time by the Implementation Team as they deem appropriate. If the Implementation Team is unable to agree upon a change, the then-existing provisions of the Implementation Plan shall remain in full force and effect.

Further Coordination and Performance.

Except as otherwise agreed upon by the parties, on a mutually agreed-upon date and time, but not less than once each quarter during the Term of this Agreement, the Implementation Team shall discuss planning issues, forecast issues, and the performance of the Parties under this Agreement. At each such meeting the Parties will discuss: (i) the administration and maintenance of the interconnections and trunk groups provisioned under this Agreement, including future plans; (ii) any areas in which performance may be improved; (iii) any problems that were encountered during the preceding quarter or anticipated in the upcoming quarter; (iv) the reasons underlying any such problem and the

effects, if any, that such problem had, has or may have on the performance of the Parties; and (v) the specific steps taken or proposed to be taken to remedy such problem. Such meeting shall also include an Operational Review, which shall address the service cycle of pre-ordering, ordering, provisioning, maintenance and billing, to assure:

- (a) that interfaces and processes are operational and that service for the unbundled Network Elements, as applicable, are successfully completed;
- (b) the accuracy rate for bills for the wholesale bill validation process.

In addition to the foregoing, the Parties through their representatives on the Implementation Team will meet to discuss any matters that relate to the performance of this Agreement, as may be requested from time to time by either of the Parties. If upon such review it is determined that the requirements of this Agreement are not being met, either Party may invoke the dispute resolution procedure described in Section 16 of the General Terms & Conditions of this Agreement.

ATTACHMENT 3
[Intentionally Omitted]

ATTACHMENT 4

[Intentionally Omitted]

ATTACHMENT 5

[Intentionally Omitted]

ATTACHMENT 6 - BILLING AND RECORDING

1) DEFINITIONS

"CABS" refers to the *Carrier Access Billing System* which is contained in a document prepared under the direction of the Billing Committee of the OBF. The *Carrier Access Billing System* document is published by Bellcore in Volumes 1, 1A, 2, 3, 3A, 4 and 5 as Special Reports SR-OPT-001868, SR-OPT-001869, SR-OPT-001871, SR-OPT-001872, SR-OPT-001873, SR-OPT-001874, and SR-OPT-001875, respectively, and contains the recommended guidelines for the billing of access and other services.

"EMR" refers to the Exchange Message Record System used among LECs for exchanging telecommunications message information for billable, non-billable, sample, settlement and study data. EMR format is contained in BR-010-200-010 *CRIS Exchange Message Record*, published by Bellcore and which defines the industry standard for exchange message records.

"MECAB" refers to the *Multiple Exchange Carrier Access Billing* document prepared under the direction the Billing Committee of the OBF. The *Multiple Exchange Carrier Access Billing* document, published by Bellcore as Special Report SR-BDS-000983, contains the recommended guidelines for the billing of access and other services provided by two or more LECs (including LECs and ALEC's), or by one LEC or ALEC in two or more states within a single LATA.

"MECOD" refers to the *Multiple Exchange Carriers Ordering and Design (MECOD) Guidelines for Access Services- Industry Support Interface*, a document developed under the auspices of the Billing Committee of the OBF. The MECOD document, published by Bellcore as Special Report SR STS-002643, establishes recommended guidelines for processing orders for access and other services which is to be provided by two or more LECS (including LECS and ALEC's), or by one LEC or ALEC in two or more states within a single LATA.

"OBF" refers to the Ordering and Billing Forum (OBF), which functions under the auspices of the Carrier Liaison Committee (CLC) of the Alliance for Telecommunications Industry Solutions (ATIS).

2) GENERAL

- a) This Attachment describes the requirements for BELL ATLANTIC and COVAD to bill and record the charges to each other covered by this Agreement. BELL ATLANTIC shall bill and record charges to COVAD for unbundled Network Elements, Reciprocal Compensation, Transient Tandem, Interim Number Portability and, in addition, BELL ATLANTIC shall bill record charges in accordance with this Attachment 6. This Attachment does not apply to services provided for resale under the PSC No. 915 Tariff.
- b) COVAD shall bill record charges to BELL ATLANTIC for Reciprocal Compensation, Transient Tandem, Interim Number Portability and, in addition, COVAD shall bill record charges in accordance with this Attachment 6.
- c) This Section also describes the Meet Point Billing arrangement between BELL ATLANTIC and COVAD.
- d) Nothing herein is intended to supersede any provisions in the P.S.C. 915 Tariff.

3) BILLABLE INFORMATION AND CHARGES

- a) BELL ATLANTIC will bill and record in accordance with this Agreement those charges COVAD incurs as a result of COVAD purchasing from BELL ATLANTIC unbundled Network Elements, as set forth in this Agreement. Each bill shall be formatted in accordance with CABS and in a few cases CRIS. It is both parties understanding that a majority of bills will be in a CABS format. For those CRIS billed services, both parties will review the practicality of migrating those services from a CRIS billed format to a CABS billed format. Each such unbundled Network Element purchased by COVAD shall be assigned a separate and unique billing code or other descriptive identifier in the form agreed to by the parties and such code or identifier shall be provided to COVAD on each bill in which charges for such unbundled Network Element appears. Each such billing code or identifier shall enable COVAD to identify the unbundled Network Element(s) as described in Part IV (Pricing Schedule) to this Agreement ordered by COVAD. Each bill shall also set forth the quantity of each such unbundled

Network Element, provided and billed to COVAD. All charges billed to COVAD must indicate the state from which such charges were incurred.

- b) BELL ATLANTIC shall provide COVAD monthly bill(s) that include all charges incurred by and credits and/or adjustments due to COVAD for those unbundled Network Elements, covered by this Agreement. Each bill provided by BELL ATLANTIC to COVAD shall include: (1) all non-usage sensitive charges incurred for the period beginning with the day after the current bill date and extending to, and including, the next bill date, (2) any known unbilled non-usage sensitive charges for prior periods, (3) unbilled usage sensitive charges for the period beginning with the last bill date and extending up to, but not including, the current bill date, (4) any known unbilled usage sensitive charges for prior periods, and (5) any known unbilled adjustments.
- c) The Bill Date, as defined herein, must be present on each bill transmitted by the parties, must be a valid calendar date and no more than one calendar year old. Charges contained on a bill may be more than one calendar year old to the extent permitted by law. In addition, on each bill where "Jurisdiction" is identified, local (Reciprocal Compensation traffic as defined in Attachment 1) shall be separately identified with the industry standard jurisdictional indicator.
- d) BELL ATLANTIC shall bill COVAD for each unbundled Network Element supplied by BELL ATLANTIC to COVAD pursuant to this Agreement at the rates set forth in this Agreement. BELL ATLANTIC will bill COVAD based on the actual charges incurred, provided, however, for those usage based charges where actual charge information is not determinable by BELL ATLANTIC because the jurisdiction (i.e., interstate, interstate/interLATA, intrastate, intrastate/intraLATA, local) of the traffic is unidentifiable, the parties will jointly develop a process to determine the appropriate charges. Measurement by the parties of terminating usage charges shall be in accordance with Part 1(e) of the Rate Application Rules in Part IV of this Agreement.
- e) Each party shall provide the other party at no additional charge a contact person for the handling of any billing questions or problems that may arise during the implementation and performance of the terms and conditions of this Attachment.
- f) The following arrangements shall apply to call usage detail records

provided by one Party ("the Providing Party") to the other ("Receiving Party") using a direct local exchange usage data feed when the message recording date for such records is over 60 days old, except as provided in (i) through (iv) below:

- (i) The Providing Party shall apply a 0.5% discount ("Late Usage Discount") to the charge otherwise applicable to the provision of such records except that the Late Usage Discount shall not apply to usage records for Unbundled Network Elements until six months after the Effective Date of this Agreement and shall not apply at all to Alternate Billed Calls.
- (ii) The Late Usage Discount shall also not apply unless the Receiving Party notifies the Providing Party that it has not received the usage records within five (5) business days of the time the Receiving Party discovers, or should have discovered using reasonable business practices, that it has not received the usage records.
- (iii) The Late Usage Discount shall not apply if the delay in provision of the usage records is not directly caused by the Providing Company.
- (iv) The Late Usage Discount shall only apply where the late usage hinders the Receiving Party's ability to promptly bill its customers.

4) MEET POINT BILLING ("MPB")

This section applies only when COVAD is a facilities-based carrier utilizing its own local switch (not unbundled Network Element switching) i.e. not to the Point of Interconnection unbundled Network Element arrangements described in Call Flows Diagram Nos. 21-28 (see Part IV). MPB as addressed in these provisions pertains to those arrangements where the only tandem switch involved is BELL ATLANTIC's used solely by BELL ATLANTIC. Other tandem arrangements including multiple tandem arrangements involving the Parties and alternate tandem providers will be addressed by the Parties in the Operations Plan.

- a) COVAD and BELL ATLANTIC will establish meet-point billing ("MPB") arrangements in accordance with the Meet Point Billing guidelines adopted by and contained in the OBF's MECAB and MECOD documents, except as modified herein. Both parties will use their best reasonable efforts, individually and collectively, to maintain provisions in their respective federal and state access tariffs, and/or provisions within the National Exchange Carrier Association ("NECA") Tariff No. 4, or any successor tariff to reflect the MPB arrangements identified in this Agreement, in MECAB and in

MECOD.

- b) COVAD and BELL ATLANTIC each seek to implement the "Multiple Bill/Single Tariff" option (where each party bills separately from its own tariff). For all traffic covered by the MPB arrangement, COVAD and BELL ATLANTIC shall bill the IXC's applicable elements, as specified in d) below, at the rates specified in each party's tariff. In implementing the "Multiple Bill/Single Tariff" scenario the recording party will provide the records to the other party at the applicable call usage detail service charges, set forth in Part IV of this Agreement. The other party will not charge the recording party for the return of the summary record.
- c) BELL ATLANTIC and COVAD shall provide to each other the billing name, billing address, and carrier identification code ("CIC") of the IXCs that may utilize any portion of each other's network in a COVAD/BELL ATLANTIC MPB arrangement in order to comply with the MPB Notification process as outlined in the MECAB document. Each party shall provide to the other such information in the format and via the medium that the parties agree. If either party does not initially record sufficient bill detail for any IXC traffic that will utilize a portion of its network in a COVAD/BELL ATLANTIC MPB arrangement, and for whom either party must supply to the other MPB billing information, each party agrees that it will assist the other in resolving these billing matters to allow that party to obtain reimbursement from the IXC by providing as much billing detail as is available to the other party, and by participating in any studies or discussions required to obtain supporting detail.
- d) BELL ATLANTIC and COVAD agree that in an MPB arrangement where one party provides local transport and the other party provides the end office switching, the party who provides the end office switching is entitled to bill any residual interconnection charges ("RIC") and common carrier line ("CCL") or loop charges associated with the traffic. The parties further agree that in those MPB situations where one party sub-tends the other party's access tandem, the party providing the access tandem is only entitled to bill the entrance facility charges, access tandem fee and any associated local transport charges and any applicable tariff charges. The parties also agree that the party who provides the end office switching is entitled to bill end office switching fees, associated local transport charges, RIC and CCL or loop charges, as appropriate, and such other applicable tariff charges. The provisions of this paragraph 4(d) shall be subject to and in accordance with the orders, rules and regulations of the FCC, as in effect from time to time.

- e) BELL ATLANTIC and COVAD will record and transmit MPB information in accordance with the EMR industry standards and in the transmission medium set forth in this Attachment. BELL ATLANTIC and COVAD will coordinate and exchange the billing account reference ("BAR") and billing account cross reference ("BACR") numbers for the MPB arrangements described in this Agreement. Each party will notify the other if the level of billing or other BAR/BACR elements change, resulting in a new BAR/BACR number.
- f) **Meet Point Billing Liability:**
- (i) These liability provisions do not apply to the Point of Interconnection unbundled Network Element arrangements (see Part IV, Call Flows Diagram Nos. 21-28) nor do they apply to arrangements involving alternate tandem providers. Records for the purpose of this Section 4 mean MPB records which shall only be provided in EMR industry standard format. Both parties will monitor and control their recording process to insure that MPB records are distributed to the other party within 10 calendar days of their creation.
 - (ii) For a period of six months per tandem, from the time that COVAD first sends or receives MPB traffic through a BELL ATLANTIC tandem which COVAD subtends, the Parties agree that they will work cooperatively to resolve issues that may arise pertaining to receipt of billable records and will attempt to provide each other with billable records or reconstruct missing records, however, neither Party will be liable to the other during that time period for failing to provide the other Party with billable records or missing records.
 - (iii) For the remainder of the first year per tandem, there will be a true up in which each Party will look at the number of non billable or missing records relative to the total records (for BELL ATLANTIC total records shall be records associated with the tandem and for COVAD total records shall be records associated with the sum of the end offices subtending that tandem) provided by the other Party during that six month period. If greater than 15% of the records for that period are not received or not billable, the recording Party will be liable for a settlement payment as described in paragraph v below.
 - (iv) For the remainder of the Term of the Agreement, there will be annual true ups in which each Party will look at the number of non billable or missing records relative to the total records (for BELL ATLANTIC total records shall be records associated with the tandem and for

COVAD total records shall be records associated with the sum of the end offices subtending that tandem) provided by the other Party during that annual period. If greater than 5% of the records for that period are not received or not billable, the recording Party will be liable for a settlement as described in paragraph v below. At the end of the first annual true up period, the Parties will review the data and may mutually agree to change the liability percentages.

(v) For each true up period where settlement payment is required, the recording Party will provide the receiving Party with a settlement payment based upon what the estimated MPB revenues for the receiving party would have been for the missing or non-billable records. The settlement will not include a) revenues associated with records where COVAD or its affiliates, parent or subsidiaries is the interexchange carrier delivering traffic to or receiving traffic from the BELL ATLANTIC tandem, b) calls for which the recording Party is not responsible for loss of records, or for the records being non billable (e.g., such as when the records have been sent by the recording Party but lost by the receiving Party, or damaged by the receiving Party) or c) where the recording Party did not receive notification of missing or non billable records from the receiving Party within the following timeframes:

1. Two business days from receipt of records that records are missing from a pack, per switch
2. Seven business days from receipt of records that records are missing CICs, or contain missing or corrupted data
3. Seven business days from receipt of records that records were not received based upon a verification of volumes process per switch (matching the Party's own switch records with the records received from the recording Party, and subtracting the difference in the amount of messages and minutes between the records)

(vi) Any settlement payment made by the recording party under this Section 4 shall be the sole and exclusive remedy of the receiving party for damages related directly or indirectly to these MPB recording arrangements. No other penalties, liquidated damages, or payments for any breach of these MPB recording arrangements shall apply.

- g) Neither COVAD nor BELL ATLANTIC will charge the other for the services rendered or for information provided pursuant to Section 4 of this Attachment except those MPB charges specifically set forth herein. Each party will provide the other a single point of contact to handle any MPB questions and will not charge for billing inquiries.
- h) Retroactive adjustments such as jurisdictional factor changes by the IXC switched access customer, if applied, will be passed through to both parties. The parties will "true up" the revenues by rerating and reallocating the amounts due or payable to each party. The costs associated with making these retroactive adjustments shall be allocated between the parties based upon the relative percentages that each party had received of the MPB revenues. The parties will agree on the best method for making the adjustments.

5) COLLOCATION

Collocation (as defined in Part III of this Agreement) billing should occur on a bill with the label Collocation Building Expenses. The CABS format would mirror the bill structure for a Miscellaneous bill. The ongoing fees (described in Part III of this Agreement) for COVAD to collocate (i.e., space, power, etc.) should be provided for as described in the existing CABS documents for how to render an Expanded Interconnection bill. For a mechanized CABS bill, the Type of Account field should be populated with a value of "E" as per the CABS specifications.

6) RECIPROCAL COMPENSATION

- a) Charges for Reciprocal Compensation should be billed on a switched bill. In a CABS format, local usage will be separately identified and displayed in the Usage Sections of the bill. The Jurisdiction Indicator will be the industry standard for Reciprocal Compensation. The face page of the bill will reflect a breakdown of Interstate, Intrastate and Local (Reciprocal Compensation) dollars. A Summary of Jurisdiction Charges will be provided at the account level. Further, the traffic exchanged pursuant to this Attachment shall be measured for terminating usage charges in actual conversation seconds and measured for originating usage charges in actual access seconds. The total conversation seconds and access seconds per chargeable traffic types shall be totaled for the entire processing cycle and then rounded to the next whole minute. Reciprocal Compensation for the termination of this traffic shall be charged at rates specified in Part IV to this Agreement.

- b) In lieu of the Reciprocal Compensation arrangement described above and where permitted by state law or Commission regulation or order, the Parties may elect to adopt a bill and keep compensation arrangement or such other mutually agreed upon compensation arrangement.

7) TRANSIENT TANDEM PROCESS AND PRICING

- (a) COVAD may use BELL ATLANTIC's tandem switch to terminate COVAD local traffic on other local carriers' networks where such local carriers are connected to the same BELL ATLANTIC tandem, or to receive local traffic originating on such other local carriers' networks. This local traffic will route between local carriers through BELL ATLANTIC's tandem switch. When COVAD is the originating carrier terminating calls to another carrier, COVAD shall be responsible for paying BELL ATLANTIC for tandem switching, except to the extent that COVAD has already paid for tandem switching via the BELL ATLANTIC Shared Transport rate, plus a blended charge which reflects a pass through of monthly Reciprocal Compensation terminating local carrier charges paid by BELL ATLANTIC to the terminating local carrier that is based upon actual local carrier rates in effect for terminating compensation from the previous month multiplied times actual minutes of use for the given month. Since the charges for each month are calculated using actual rates from the previous month, the initial month under this Agreement will be estimated and based upon a local study. Parameters will be developed to insure that if actuals are collected in the month succeeding the initial month which differ from the estimated value by more than two thousand dollars, BELL ATLANTIC will credit COVAD for that amount which COVAD has overpaid or COVAD will pay BELL ATLANTIC for that amount which COVAD has underpaid. The prices for transient tandem switching, including all applicable associated operations support charges, are set forth in this Part IV to this Agreement.
- (b) When COVAD is the terminating carrier using its own (not unbundled Network Element) switching facilities, BELL ATLANTIC shall pay COVAD all terminating Reciprocal Compensation for local and toll based upon actual minutes of use and rates in effect for that month. The Parties will work cooperatively on billing disputes and uncollectible issues. 5

8) LOCAL NUMBER PORTABILITY

- a) In accordance with the terms and conditions set forth in this Attachment 6, each party shall record and provide to the other all call detail information associated with a call to a party's local exchange customer whose telephone number has been ported from the other party under INP as further described in Section 19 of the General Terms and Conditions of this Agreement.

- b) When an IXC terminates an InterLATA or IntraLATA toll call to either party's local exchange customer whose telephone number has been ported from one party to the other, the parties agree that the party to whom the number has been ported shall receive revenues from those IXC access charges associated with end office switching, local transport, RIC and CCL, as appropriate, and such other applicable charges. The party from whom the number has been ported shall be entitled only to receive any entrance facility fees, access tandem fees and appropriate local transport charges, and any INP fees (i.e., such as RCF charges) set forth in this Agreement. Such access charge payments will be adjusted to the extent that the paying party has already paid Reciprocal Compensation for the same minutes of use. When a call for which access charges are not applicable is terminated to a party's local exchange customer whose telephone number has been ported from the other party, the parties agree that the Reciprocal Compensation arrangements described in this Attachment shall apply.

9) ISSUANCE OF BILLS - GENERAL

- a) BELL ATLANTIC and COVAD will issue all bills for services and facilities covered by this Agreement in accordance with the terms and conditions set forth in this Section. BELL ATLANTIC and COVAD will establish monthly billing dates ("Bill Date") for each Billing Account Number ("BAN"), as further defined in the CABS documents, which Bill Date shall be the same day month to month. Each BAN shall remain constant from month to month, unless changed as agreed to by the parties. Each Party shall provide the other Party at least thirty (30) calendar days written notice prior to changing, adding or deleting a BAN. The Parties will provide one billing invoice associated with each BAN. Each invoice must contain an invoice number (which will vary from month to month). On each bill associated with a BAN, the appropriate invoice number and the charges contained on such invoice must be reflected. All bills are due within the timeframes specified in Section 10.1 and 10.2 of the General Terms and Conditions of this Agreement

- b) Except as otherwise provided below, when BELL ATLANTIC and COVAD issue CABS bills they shall contain such billing data and information in accordance with CABS Version 26.0, or such later versions of CABS as are published by Bellcore, or its successor. For meet-point billing arrangements as set forth in Section 4 of this Attachment, such billing data and information shall also conform to the standards set forth in the MECAB document, or such later versions as are adopted by Bellcore, or its successor. For as long as and to the extent that CABS standards have not been established with respect to formatting, such billing data and information may be formatted in a CRIS billed format or in such other format or formats as shall be reasonable under the circumstances, subject to the approval of the receiving Party, which approval shall not be unreasonably withheld. It is both parties understanding that a majority of bills will be in a CABS format. For those CRIS billed services, both parties will review the practicality of migrating those services from a CRIS billed format to a CABS billed format. BELL ATLANTIC has indicated that they have not completely adopted CABS Version 26.0 yet but agree to provide COVAD with a differences list for any variance from Version 26.0.

- c) Payment by the Parties will be based on the full detailed version of the bill. If either party requests an additional copy(ies) of a bill, such party shall pay the other party a reasonable fee per additional bill copy, unless such copy was requested due to errors, omissions, or corrections or the failure of the

transmission to comply with the specifications set forth in this Agreement.

- d) To avoid transmission failures or the receipt of billing information that cannot be processed, the parties shall provide each other with their respective process specifications and edit requirements. COVAD shall comply with BELL ATLANTIC's processing specifications when COVAD transmits billing data to BELL ATLANTIC. BELL ATLANTIC shall comply with COVAD's processing specifications when BELL ATLANTIC transmits billing data to COVAD. COVAD and BELL ATLANTIC shall provide each other reasonable notice if a billing transmission is received that does not meet such party's specifications or that such party cannot process. Such transmission shall be corrected and resubmitted to the other party, at the resubmitting party's sole expense, in a form that meets the specifications set forth in this Attachment. The payment due date for such resubmitted transmissions will be twenty (20) days from the date that the transmission is received in a form that can be processed and that meets the specifications set forth in this Attachment.

10) ELECTRONIC TRANSMISSIONS

- a) BELL ATLANTIC and COVAD agree that each party will transmit CABS billing information and data in the appropriate CABS format electronically via Connect: Direct (formerly known as Network Data Mover) to the other party at the location specified by such party. The parties agree that a T1.5 or 56kb circuit to Gateway for Connect: Direct is required. COVAD data centers will be responsible for originating the calls for data transmission via switched 56kb or T1.5 lines. If BELL ATLANTIC has an established Connect: Direct link with COVAD, that link can be used for data transmission if the location and applications are the same for the existing link. Otherwise, a new link for data transmission must be established. BELL ATLANTIC must provide COVAD its Connect: Direct Node ID and corresponding VTAM APPL ID before the first transmission of data via Connect: Direct. COVAD will supply to BELL ATLANTIC its RACF ID and password before the first transmission of data via Connect: Direct. Any changes to either party's Connect: Direct Node ID must be sent to the other party no later than twenty-one (21) calendar days before the changes take effect.
- b) The following dataset format shall be used as applicable for those CABS charges transmitted via Connect: Direct in CABS format:

Production Dataset

AF25.AXXXXYYY.AZZZ.DDDEE	Production Dataset Name
AF25 =	Job Naming Convention
AXXXX =	Numeric Company Code
YYY =	BELL ATLANTIC Remote
AZZZ =	RAO (Revenue Accounting Office)
DDD =	BDT (Billing Data Tape with or without CSR) Or CSR (Customer Service Record)
EE =	01 thru 31 (Bill Period) (optional) or GA (US Postal-State Code)

Test Dataset

AF25.ATEST.AXXXX.DDD	Test Dataset Name
AF25.ATEST =	Job Naming Convention
AXXXX =	Numeric Company Code
DDD =	BDT (Billing Data Tape with or without CSR) Or CSR (Customer Service Record)

11) TAPE OR PAPER TRANSMISSIONS

- a) In the event either party does not have Connect: Direct capabilities upon the effective date of this Agreement, such party agrees to establish Connect: Direct transmission capabilities with the other party within the time period mutually agreed and at the establishing party's expense. Until such time, the parties will transmit billing information to each other via magnetic tape or paper, as agreed to by COVAD and BELL ATLANTIC. Billing information and data contained on magnetic tapes or paper for payment shall be sent to the parties at the following locations. The parties

acknowledge that all tapes transmitted to the other party via U.S. Mail or Overnight Delivery and which contain billing data will not be returned to the sending party.

TO COVAD:

Tape Transmissions via U.S. Mail:	COVAD _____ att: _____
Tape Transmissions via Overnight Delivery:	COVAD _____ att: _____
Paper Transmissions via U.S. Mail:	COVAD _____ att: _____
Paper Transmissions via Overnight Delivery:	COVAD _____ att: _____

--	--

TO BELL ATLANTIC:

Tape Transmissions	BELL ATLANTIC 1095 Avenue of the Americas Fourteenth Floor New York, NY 10036 Attn: CLEC Billing
Paper Transmissions	BELL ATLANTIC 1095 Avenue of the Americas Fourteenth Floor New York, NY 10036 Attn: CLEC Billing

- b) Each Party will adhere to the tape packaging requirements set forth in this subsection. When a third party is utilized, the billing party will work to ensure conformance to the tape packaging requirements set forth in this subsection. In addition, the Parties shall provide each other reasonable notice if a billing transmission is received that does not meet such party's specifications or that such Party cannot process. Such transmission shall be corrected and resubmitted to the other Party, at the resubmitting Party's sole expense, in a form that can be processed. The payment due date for such resubmitted transmissions will be twenty (20) days from the date that the transmission is received in a form that can be processed and that meets the specifications set forth in this Attachment. Each Party will clearly mark on the outside of each shipping container its name, contact and return address.

- c) All billing data transmitted via tape must be provided on a cartridge (cassette) tape and must be of high quality, conform to the parties' record and label standards, 9-track, odd parity, 6250 BPI, group coded recording.

mode and extended binary-coded decimal interchange code ("EBCDIC"). Each reel of tape must be 100% tested with full width certification and permanent error free at final inspection. COVAD reserves the right to destroy a tape that has been determined to have unrecoverable errors. COVAD also reserves the right to replace a tape with one of equal or better quality.

- d) Billing data tapes shall have the following record and label standards. The dataset serial number on the first header record of an IBM standard tape label also shall have the following format.

	CABS BOS
Record length	225 bytes (fixed length)
Blocking factor	84 records per block
Block size	18,900 bytes per block
Labels	Standard IBM Operating System

- e) The serial would be determined by the sending company, to meet IBM standard label format requirements. The dataset name as well as each party's name, address and contact shall further identify the tape. The external and internal label should be the same.
- f) Tape labels shall conform to IBM OS/VS Operating System Standards contained in the IBM Standard Labels Manual (GC26-3795-3). IBM standard labels are 80-character records recorded in EBCDIC, odd parity. The first four characters identify the labels:

<u>Volume 1</u>	<u>Volume label</u>
HDR1 and HDR2	Data set header labels
EOV1 and EOV2	Data set trailer labels (end-of-volume for multi-reel files)
EOF1 and EOF2	Data set trailer labels (end-of-data-set)

The HDR1, EOV1, and EOF1 labels use the same format and the HDR2, EOV2, and EOF2 labels use the same format.

- g) The Standard Volume Label Format (Vol. 1) is described below:

M:\Kw24778\Covad\Covadny4.Doc

FIELD NAME	CONTENTS
Label Identifier (3 bytes)	The characters "VOL" identify this label as a volume label.
Label Number (1 byte)	The relative position of this label within a set of labels of the same type; it is always a 1 for the IBM standard volume label.
Volume Serial Number (6 bytes)	A unique identification code, normally numeric characters (000001-999999), but may be alphanumeric; if fewer than 6 characters, must be left-justified. This same code should also appear on the external (flat) surface of the volume for visual identification.
Reserved (1 byte)	Reserved for future use - should be recorded as blanks.
VTOC Pointer (10 bytes)	Direct-access volumes only. This field is not used for tape volumes and should be recorded as blanks.
Reserved (10 bytes)	Reserved for future use - should be recorded as blanks.
Owner Name and Address Code(10 bytes)	Indicates a specific customer, person, installation, department, etc., to which the volume belongs. Any code or name is acceptable.
Reserved (29 bytes)	Reserved for future use - should be recorded as blanks.

- h) The IBM Standard Dataset Label 1 Format (HDR1, EOVS1, EOF1) is described below:

FIELD NAME	CONTENTS
Label Identifier (3 bytes)	Three characters that identify the label are: <ul style="list-style-type: none"> • HDR Header label (at the beginning of a dataset) • EOVS Trailer label (at the end of a tape volume, when the dataset

	<ul style="list-style-type: none"> continues on another volume) • EOF Trailer label (at the end of a dataset).
Label Number (1 byte)	The relative position of this label within a set of labels of the same type; it is always a 1 for dataset label 1.
Dataset Identifier (17 bytes)	The rightmost 17 bytes of the dataset name (includes GnnnnVnn if the dataset is part of a generation data group). If the dataset name is less than 17 bytes, it is left-justified and the remainder of this field is padded with blanks.
Dataset Serial Number (6 bytes)	The volume serial number of the tape volume containing the dataset. For multi-volume datasets, this field contains the serial number of the first volume of the aggregate created at the same time. The serial number can be any 6 alphanumeric characters, normally numeric (000001-999999). If the number of characters is fewer than 6 characters, the code must be left-justified and followed by blanks.
Volume Sequence Number (4 bytes)	A number (0001-9999) that indicates the order of volume within the multi-volume group created at the same time. This number is always 0001 for a single volume dataset.
Dataset Sequence Number (4 bytes)	A number (0001-9999) that indicates the relative position of the dataset within a multi-dataset group. This number is always 0001 for a single dataset organization.
Generation Number (4 bytes)	If the dataset is part of a generation data group, this field contains a number from 0001 to 9999 indicating the absolute generation number (the first generation is recorded as 0001). If the dataset is not part of a generation data group, this field contains blanks.
Version Number Of	If the dataset is part of a generation data

Generation (2 bytes)	group, this field a number from 00 to 99 indicating the version number of the generation (the first version is recorded as 00). If the dataset is not part of a generation data group, this field contains blanks.
Creation Date (6 bytes)	Year and day of the year when the dataset was created. The date is shown in the format byydd where: <ul style="list-style-type: none"> • b = blank • yy = year(00-99) • ddd = day(001-366)
Expiration Date (6 bytes)	Year and day of the year when the dataset may be scratched or overwritten. The data is shown in the format byydd where: <ul style="list-style-type: none"> • b = blank • yy = year (00-99) • ddd = day (001-366)
Dataset Security (1 byte)	A code number indicating the security status of the dataset is as follows: <ul style="list-style-type: none"> • 0 No password protection • 1 Password protection Additional identification of the dataset is required before it can be read, written, or deleted (ignored if volume is RACF-defined) • 3 Password protection Additional identification of the dataset is required before it can be read, written, or deleted (ignored if volume is RACF-defined).
Block Count (6 bytes)	This field in the trailer label shows the number of data blocks in the dataset on the current volume. This field in the header label is always zeros (000000).
System Code (13 bytes)	Unique code that identifies the system.
Reserved (7 bytes)	Reserved for future use - should be

	recorded as blanks.
--	---------------------

i) The IBM Standard Dataset Label 2 Format (HDR2, EOVS, EOF2) always follows dataset label 1 and contains additional information about the associated dataset as described below:

FIELD NAME	CONTENTS
Label Identifier (3 bytes)	<p>Three characters that identify the label are as follows:</p> <ul style="list-style-type: none"> • HDR Header label (at the beginning of a dataset) • EOVS Trailer label (at the end of a tape volume, when the dataset continues on another volume) • EOF Trailer label (at the end of a dataset).
Label Number (1 byte)	The relative position of this label within a set of labels of the same type; it is always a 2 for dataset label 2.
Record Format (1 byte)	<p>An alphabetic character that indicates the format of records in the associated dataset as follows:</p> <ul style="list-style-type: none"> • F Fixed length • V Variable length • U Undefined length.
Block Length (5 bytes)	<p>A number up to 32760 that indicates the block length, in bytes. Interpretation of the number depends on the following associated record format in Field 3:</p> <ul style="list-style-type: none"> • Format F - Block length (must be a multiple of the logical record length in Field 5) • Format V - Maximum block length (including the 4 byte length indicator in the block) • Format U - Maximum block length.

Record Length (5 bytes)	<p>A number that indicates the record length, in bytes. Interpretation of the number depends on the following associated record format in Field 3:</p> <ul style="list-style-type: none"> • Format F - Logical record length • Format V - Maximum logical record length (including the 4 byte length indicator in the records) • Format U - Zeros. 						
Tape Density (1 byte)	<p>A code indicating the record density of the tape, as follows:</p> <table style="margin-left: 40px;"> <thead> <tr> <th style="text-align: left;"><u>Recording Density</u></th> <th style="text-align: left;"><u>9-Track Tape</u></th> </tr> </thead> <tbody> <tr> <td style="padding-left: 20px;">3</td> <td>1600 (PE)</td> </tr> <tr> <td style="padding-left: 20px;">4</td> <td>6250 (GCR)</td> </tr> </tbody> </table> <p>PE - is for phase encoded mode GCR - is for group coded recording mode.</p>	<u>Recording Density</u>	<u>9-Track Tape</u>	3	1600 (PE)	4	6250 (GCR)
<u>Recording Density</u>	<u>9-Track Tape</u>						
3	1600 (PE)						
4	6250 (GCR)						
Dataset Position (1 byte)	<p>A code, indicating a volume switch, is as follows:</p> <ul style="list-style-type: none"> 0 - No volume switch has occurred 1 - A volume switch previously occurred. 						
Job/Job Step (17 bytes)	<p>Identification of the job and job step that created the dataset. The first 8 bytes contain the name of the job, the ninth byte is a slash (/), and the final 8 bytes contain the name of the job step.</p>						
Tape Recording Technique (2 bytes)	<p>A code or blanks indicating the tape recording technique used. This field is recorded as blanks for 9-track tape. The only technique available for 9-track tape is odd parity and no translation.</p>						
Control Characters (1 byte)	<p>A code indicating whether a control character set was used to create the dataset and the type of control characters used:</p> <ul style="list-style-type: none"> A Contains ASCII control characters M Contains machine control 						

	characters b Contains no control characters.
Reserved (1 byte)	Reserved for future use - should be recorded as blanks.
Block Attribute (1 byte)	A code indicating the block attribute used to create the dataset: B Blocked records S Spanned records R Blocked and spanned records b No blocked and no spanned records.
Reserved (8 bytes)	Bytes 40-42 - reserved for future use -should be blanks. Bytes 43-47 - (3420 tape units only) serial number of creating tape unit. Blank for other units.
Checkpoint Dataset (1 byte)	In VS2-Release 2, this byte contains the identifier character C if the dataset is a checkpoint dataset; the byte is blank if the dataset is not a check point dataset or in other releases of the VS systems.
Reserved (32 bytes)	Reserved for future use - should be recorded as blanks.

12) TESTING REQUIREMENTS

- a) The Parties shall send bill data in the appropriate mechanized format (e.g., CABS) for testing to ensure that bills can be processed and that bills comply with the requirements of this Attachment. After receipt of the test data the receiving Party will notify the sending party whether or not the billing transmission meets testing specifications. If the transmission fails to meet the receiving Party's testing specifications, the sending Party shall make the necessary corrections. At least one (1) set of testing data must meet the receiving party's testing specifications prior to the sending party sending a mechanized production bill for the first time via electronic transmission. Thereafter, the sending Party may begin sending the receiving party mechanized production bills on the next Bill Date, or within ten (10) days, whichever is later, unless otherwise agreed to in writing.

- b) At least 30 days prior to changing transmission mediums (e.g., from paper to mechanized), the sending Party shall send bill data in the appropriate mechanized format for testing to ensure that the bills can be processed and that the bills comply with the requirements of this Attachment. The sending party agrees that it will not send bill data in the new mechanized format until such bill data has met the testing specifications as set forth in this subsection.

- c) BELL ATLANTIC shall provide to COVAD's Company Manager, located at: COVAD; _____, BELL ATLANTIC originating or state level company code so that it may be added to COVAD's internal tables at least thirty (30) calendar days prior to testing or prior to a change in BELL ATLANTIC's originating or state level company code. COVAD shall provide to the designated BELL ATLANTIC representative, COVAD's originating or state level company code so that it may be added to BELL ATLANTIC's internal tables at least thirty (30) days prior to testing or prior to a change in COVAD's originating or state level company code.

- d) During the testing period, each party shall transmit to the other billing data and information via paper transmission to the respective addresses as set forth in Section 10 of this Attachment. Each party shall send test tapes to the other at the following locations:

Test Tapes:	COVAD
	<hr/> <hr/> <hr/> <hr/> <hr/> <i>BELL ATLANTIC</i> <i>[TO BE DESIGNATED BY BELL ATLANTIC IN WRITING]</i>

13) ADDITIONAL REQUIREMENTS

- a) The parties agree that if they transmit data in a mechanized format, they will also comply with the following specifications which are not contained in CABS guidelines but which are necessary for the parties to process billing information and data:
- (1) The BAN shall not contain embedded spaces or low values.
 - (2) The Bill Date shall not contain spaces or non-numeric values.
 - (3) Each bill must contain at least one detail record.
 - (4) Any "From" Date should be less than the associated "Thru" Date and neither date can contain spaces.
 - (5) The Invoice Number must not have embedded spaces or low values.

14) [Intentionally Omitted]

15) PAYMENT OF CHARGES

Payments shall be made in U.S. Dollars via a clearing house ("ACH") to the other party's bank account. At least thirty (30) days prior to the first transmission of billing data and information for payment, BELL ATLANTIC and COVAD shall provide each other the name and address of its bank, its account and routing number and to whom billing payments should be made payable. If such banking information changes, each party shall provide the other party at least sixty (60) days written notice of the change and such notice shall include the new banking information. The parties will render payment via ACH (EFT). COVAD will provide BELL ATLANTIC with one address to which such payments shall be rendered and BELL ATLANTIC will provide to COVAD with only one address to which such payments shall be rendered. In the event COVAD receives multiple and/or other bills from BELL ATLANTIC which are payable on the same date, COVAD may remit one payment for the sum of all such bills payable to BELL ATLANTIC's bank account specified in this subsection and COVAD will provide BELL ATLANTIC with a payment advice. Each Party shall provide the other Party with a contact person for the handling of billing payment questions or problems.

Access bills and bills for Unbundled Network Elements under this Agreement will

be provided as separate bills with separate amounts due.

16) BILLING DISPUTES

- a) Billing disputes shall be handled in accordance with the procedures set forth in Section 10.3 of the General Terms and Conditions of the Agreement.
- b) The Parties agree to establish a process by which closure of a specific billing period will occur by joint agreement. The Parties agree that a bill closure process will be established within twelve months of the execution of this Agreement.

17) LATE PAYMENT CHARGES

- a) Late payment charges shall be as set forth in Section 10.2 of the General Terms and Conditions of this Agreement.

18) ADJUSTMENTS

Adjustments for incorrect charges and overcharges shall be set forth in the appropriate section of the bill pursuant to CABS standards and/or CRIS standards for the billing format being utilized.

19) RECORDING OF CALL INFORMATION

- a) When COVAD purchases unbundled Network Elements from BELL ATLANTIC, the Parties agree to record call information in accordance with this subsection. To the extent technically feasible, each Party will record all call detail information associated with every call originated from or terminated to the other Party's local exchange customer through each Party's tandem or end office switches for purposes of either party billing terminating or originating charges, including access charges, to IXCs, ILEC, CLECs or ICOs, except that in cases where the receiving Party does not need such data (e.g., Call Flows 2, 4, 7, 10, 11) the recording Party is not required to record all call detail. These records shall be provided at a Party's request and shall be formatted pursuant to Bellcore standards and the terms and conditions of this Agreement. These records shall be transmitted to the other Party daily in EMR format via Connect: Direct, provided however that if COVAD and BELL ATLANTIC do not have Connect: Direct capabilities, such records shall be transmitted as the parties agree. BELL ATLANTIC and COVAD agree that they will retain, at each Party's sole expense, copies of all EMR records transmitted to the other Party for at least 45 days after transmission to the other party.
- b) BELL ATLANTIC and COVAD shall provide to each other the billing name, billing address, and carrier identification code ("CIC") of the CLEC, ICO or IXCs that may utilize any portion of each other's network in a COVAD/BELL ATLANTIC Meet Point Billing, Reciprocal Compensation or Transient Tandem arrangement. Such information shall be provided to each other in the format and via the medium that the parties agree. If either party does not initially record sufficient bill detail for any CLEC, ICO or IXC traffic that will utilize a portion of its network in a COVAD/BELL ATLANTIC Meet Point Billing, Reciprocal Compensation or Transient Tandem arrangement, and for whom either Party must supply to the other billing information, each Party agrees that it will assist the other Party in resolving these billing matters to allow that party to obtain reimbursement from the CLEC, ICO or IXC by providing as much billing detail as is available to the other Party, and by participating in any studies or discussions required to obtain supporting detail.
- c) The Parties agree that they will provide each other a single person to contact regarding any data exchange problems.

Intentionally Left Blank

APPENDIX I
CARRIER BILLING MANAGEMENT

**COST ESTIMATE BY SUPPORT FUNCTION TO DO COVAD/BELL ATLANTIC MEET-
POINT BILLING—BASED UPON A ONE YEAR TERM**

FUNCTION	TIME	UNIT	COST/ UNIT*
CUSTOMER CARE <ul style="list-style-type: none"> • Receive call from IXC or BELL ATLANTIC •.... Log Inquiry into Lotus Notes •.... Research problem/determine resolution •.... Communicate resolution to originator •.... If other than \$ adjustment, input change •.... Collection of delinquent payments 	.75 hr	INQUIRY "TBD" @ that time	\$26.93
BILLING ADJUSTMENT <ul style="list-style-type: none"> •.... Receive/Initiate call to BELL ATLANTIC •.... Obtain adjustment amount and authorization •.... Determine Phrase code or reason for adjustment •.... Access Billing System/input adjustment •.... Calculation of Late Payment Penalty, when applicable •.... Validate adjustment report •.... Verify Adjustment on Bill prior to release 	.50 hr	ADJUSTMENT	\$17.95

<p>RECEIVABLES "SETUP" AND POSTING</p> <p>.....<i>Receivable "Set-up"</i></p> <ul style="list-style-type: none"> •.... Access Billing System and create Bill rendered report •.... Send Bill Rendered report to BELL ATLANTIC.(Setup) 	<p>.50 hr</p>	<p>REPORT</p>	<p>\$17.95</p>
<p>.....<i>Payment Posting</i></p> <ul style="list-style-type: none"> •.... Receive payment details from BELL ATLANTIC •.... Access Billing System/input payment details •.... Determine prior months balances •.... Validate payment report •.... Verify payment posted on bill prior to release 	<p>.25 hr</p>	<p>PAYMENT</p>	<p>\$8.97</p>
<p>BILLING TABLE INPUT AND MAINTENANCE</p> <p>.....<i>Initial One-Time activities or Multiple inputs</i></p> <ul style="list-style-type: none"> •.... Receive IXC Profile data; Name/Address/Contact •.... Receive Tariff and Late Payment Penalty rates from BELL ATLANTIC •.... Confirm current NPA/NXX and MPB %'s with BELL ATLANTIC •.... Access Billing System/input profile, NPA,NXX & MPB %'s, Tariff and Late Payment Penalty Rates •.... Validate profile and table data 		<p>TO BE NEGOTIATED AT THAT TIME</p>	

..... Maintenance or Single inputs	Profile	BAN NPA/NXX TARIFF RATE	No Charge \$8.97
..... Receive "new/changed" IXC Profile data; Name/Address/Contact	.50 hr		
..... Receive "new/changed" Tariff and Late Payment rates from BELL	All Oth.	MSG	TIER RATE SCHE- DULE
..... ATLANTIC Confirm "new/changed" NPA/NXX and MPB %'s with BELL ATLANTIC	.25 hr		
..... Access Billing System/input "new/changed" data			
..... Validate profile and table data			
MESSAGE PROCESSING/BILL CREATION/MAILING			

DOES NOT INCLUDE ANY COSTS RELATED TO PRE-BILL CERTIFICATION

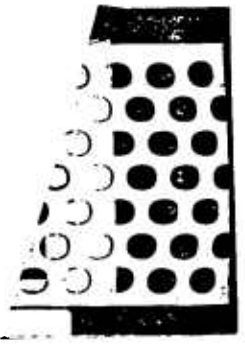

AMENDMENT TO INTERCONNECTION AGREEMENT

This amendment is made by and between COVAD Communications Co., d/b/a COVAD Communications Co., a California corporation, having an office at 3650 Bassett St., Santa Clara, CA 95054 ("COVAD"), and New York Telephone Company, d/b/a BELL ATLANTIC, a New York corporation, having an office at 1095 Avenue of the Americas, New York, New York 10036 ("BA").

WHEREAS, BA and COVAD (individually a "Party" and collectively the "Parties") have entered into an agreement for the interconnection of their telecommunication networks (the "Interconnection Agreement") dated December 16, 1997; and

WHEREAS, the Parties desire to amend that agreement as set forth herein,

NOW, THEREFORE, in consideration of the mutual provisions contained herein and other good and valuable consideration, the receipt and sufficiency of which are hereby acknowledged, BA and COVAD agree as follows:

1. The Interconnection Agreement is hereby amended by deleting the first three paragraphs of Section 2.9.1(g) and adding the following three paragraphs at the start of Section 2.9.1(g):

(g) ADSL and HDSL Compatible Local Loops

At COVAD's request, BELL ATLANTIC will provide ADSL and HDSL Compatible Local Loops, described in paragraph (4) of this subsection, after successful completion of a Technical Trial, if necessary, and an Operational Trial for Two-Wire ADSL, Two-Wire HDSL and Four-Wire HDSL Compatible Local Loop types. A Technical Trial is required prior to an Operational Trial; however, the Technical and/or operational Trial may or may not involve COVAD and may or may not take place in New York. Upon COVAD's request, BELL ATLANTIC will advise COVAD as to the status of any technical and/or operational trial(s) then being conducted or already completed by BELL ATLANTIC in any state. The Parties agree that if such technical or operational trials are being or have been conducted by BA, then BA shall in its sole discretion decide whether there is a need for a Technical and/or Operational Trial with COVAD in New York. The ADSL and HDSL Compatible Local Loops must terminate on a NID at a customer premises and in COVAD's Collocation space.

For each of the 2-wire ADSL, 2-wire HDSL, and 4-wire HDSL types of unbundled Local Loops, if BELL ATLANTIC makes generally available in any of its service territories in the state of New York an ADSL or HDSL service that

utilizes such Local Loop type, or if BA successfully completes a Technical Trial (whether that provided for in herein or a trial with another Telecommunications Carrier) for such unbundled Local Loop type, then the Technical Trial otherwise required by Section 2.9.1(g)(1) will not be required for such unbundled Local Loop type. BELL ATLANTIC may also waive the need for the Operational Trial, and BELL ATLANTIC will then provide Covad, and Covad may utilize, such unbundled Local Loop types, subject to the provisions of section 2.9.1 below. BELL ATLANTIC shall exercise its best efforts to utilize all technical data available to it to satisfy its requirement to conduct a Technical Trial. BELL ATLANTIC shall share with COVAD, upon COVAD's written request, the technical trial results related to potential interference issues of any ADSL or HDSL technical trial that BELL ATLANTIC has undertaken with another Telecommunications Carrier in its service territory, to the extent that the information is not proprietary to the other Telecommunications Carrier. The results of such other Technical Trials may be used to satisfy the Technical Trial required under Section 2.9.1(g)(1).

If a Technical Trial is not required, but BELL ATLANTIC has determined that an Operational Trial is necessary, COVAD may request an Operational Trial in accordance with Section 2.9.1(g)(1), provided that COVAD agrees to (i) conform to BELL ATLANTIC's published technical standards, guidelines or procedures that result from other technical trials or that are used in the general deployment of such service(s), and (ii) use technology that is substantially similar to that underlying the technical data subject to the other technical trials, relied on by BELL ATLANTIC, or used in the general deployment of such service(s).

This Amendment becomes effective upon signature by each of the Parties, and may be executed in counterparts.

COVAD Communications Co.

NEW YORK TELEPHONE Company

By: 

By: 

Printed: Charles J. McMinn

Printed: Jacob J. Goldberg

Title: President and CEO

Title: President -
Telecom Industry Services

Date: 7/1/98

Date: 7/13/98

AMENDMENT TO INTERCONNECTION AGREEMENT

This amendment is made by and between New York Telephone Company, d/b/a/ Bell Atlantic-New York ("BA"), a New York corporation with offices at 1095 Avenue of the Americas, New York, New York 10036 and COVAD Communications Co., d/b/a COVAD ("COVAD"), a California corporation with offices at 2330 Central Expressway, Santa Clara, CA 95050-2516.

WHEREAS, BA and COVAD (individually a "Party" and collectively the "Parties"), have entered into an Interconnection Agreement (the "Interconnection Agreement") dated December 16, 1997; and

WHEREAS, the Parties desire to amend that agreement as set forth herein,

NOW, THEREFORE, in consideration of the mutual provisions contained herein and other good and valuable consideration, the receipt and sufficiency of which are hereby acknowledged, BA and COVAD agree as follows:

1. The Interconnection Agreement is hereby amended by adding the following as Section 2.6 of Part III:

2.6 Covad may collocate Digital Subscriber Line Access Multiplexers ("DSLAM"s) in its collocated space, subject to the requirements of this Section. Covad may install any equipment allowed by Applicable Laws, including Remote Switching Modules ("RSM"s) and DSLAMs in its Collocation space unless and until the FCC, the Commission, or a court of competent jurisdiction determines that incumbent LECs need not permit Collocation of such equipment, in which event BA must allow Covad a reasonable transition period for removing, replacing or modifying such equipment, or for otherwise negotiating a mutually satisfactory alternative arrangement with BA. Covad agrees that any such equipment must comply with National Equipment Building System ("NEBS") Level III. Covad agrees that such RSM or DSLAM equipment as may be collocated at BA premises will not be used to provide switching functionality unless such use is specifically approved by the Commission.

BA will permit Covad to install, maintain, repair and use ATM cross-connect equipment in BA Premises where Covad has established a physical Collocation arrangement, provided that such equipment will be used to support pre-defined point-to-point Private Virtual Connections ("PVC"s) between the Premises-located equipment and other points off BA's network. The ATM cross-connect equipment shall be used exclusively for aggregating and transporting traffic and will not under any circumstances be used for dynamic routing or switching of traffic. BA shall have the right at its own expense to audit Covad's use of such collocated equipment, and if it finds that Covad is using the equipment for switching of Local Traffic or other uses prohibited hereunder, BA may either invoke the dispute resolution provisions of this Agreement, or notify Covad in writing and Covad shall then remove such equipment from BA's Premises.

2. The Interconnection Agreement is hereby amended by adding the following as Section 2.7 of Part III:

2.7 Collocation shall be made available to Covad on BA Premises as required by Applicable Law and in a manner that is at parity to the priorities that BA provides to persons who are permitted to collocate, including BA's Affiliates that are required to collocate. Pursuant to applicable Tariff, or to Schedule 2.7 until such time as an approved Tariff is effective, BA will provide Covad with shared cage Collocation, in which Covad can collocate equipment in another collocating entity's physical Collocation arrangement. Upon request by Covad for shared cage Collocation, the Parties will negotiate expeditiously and in good faith to resolve any operational, provisioning and billing issues that are not covered by an applicable Tariff or Schedule 2.7. Notwithstanding any other provision of this Agreement, BA will provide Covad with alternative Collocation arrangements (including "cage-less" physical Collocation) to the extent that such arrangements are required by Applicable Law, and may consider other alternative arrangements proposed by Covad. BA shall provide Collocation at additional locations for placement of equipment necessary for Interconnection or for access to unbundled Network Elements to the extent required by Applicable Law.

3. The Interconnection Agreement is hereby amended by adding the following as Section 2.11 in Part II:

2.11 The unbundled Network Elements and rates specified in this Agreement shall be made available by BA to Covad pursuant to and to the extent required by Applicable Law. Unless otherwise provided in this Agreement, the unbundled Network Elements specified in this Agreement shall be made available by BA to Covad for ordering and provisioning on the Effective Date. To the extent required by Applicable Law, and notwithstanding anything to the contrary in this Section, BA will offer Covad nondiscriminatory access to ADSL-2W, HDSL-2W, and HDSL-4W ULLs to the extent that BA offers such ULLs to any Telecommunications Carrier in the state of New York. Nothing in the preceding sentence or elsewhere in this Section is intended to obligate Bell Atlantic to provide ADSL-2W, HDSL-2W and HDSL-4W ULLs as of a specific date (other than as may be required by Applicable Laws) or to constitute a waiver of any right Covad

may have to obtain such Loops. In the event that a change in Applicable Law requires Bell Atlantic to provide ADSL-2W, HDSL-2W and HDSL-4W ULLs or other types of DSL-compatible Loops, the Parties will negotiate in good faith a non-discriminatory, commercially reasonable schedule for the availability of each such type of Loop consistent with Applicable Law.

4. The Interconnection Agreement is hereby amended by adding the following as Schedule 2.7:

SCHEDULE 2.7

COLLOCATION: SHARED CAGE ARRANGEMENT

1. Service Description

- (A) Shared Cages provide an additional option to Covad for Interconnection and access to unbundled Network Elements. Shared Cages refers to an arrangement in which a Collocation node is shared by two CLECs pursuant to terms and conditions agreed to by those CLECs.
- (B) For established collocation nodes, the initial CLEC is the "Collocator of Record" ("COR"), or "host" collocator; the other collocator participating in the sharing arrangement is referred to in this Agreement as the "guest". When two collocators request establishment of a new Collocation node, to be used as a Shared Cage, one of the participating CLECs must agree to be the COR and the other to be the guest. The host collocator is BA's customer, and has all of the rights and obligations applicable under this Agreement and the applicable Tariff to CLECs purchasing Collocation-related services, including, without limitation, the obligation to pay all applicable charges, whether or not the COR is reimbursed for all or any portion of such charges by the guest. Neither this Agreement, nor any actions taken by BA or the COR in compliance with this Agreement or the applicable Tariff, shall create a contractual, agency, or any other type of relationship between BA and the guest collocator in a sharing arrangement; and BA does not assume any liability or obligation to the guest for any actions of the COR. The two involved collocators are solely responsible for determining whether to share a cage, and if so upon what terms and conditions.

2. Shared Cage Arrangement

- (A) The host CLEC must notify BA in writing of its intention to share its cage space and provide BA with a certificate of insurance from the guest before the guest occupies the cage.
- (B) All orders for Telecommunications Services or unbundled Network Elements must be placed by or on behalf of the COR. The host and guest may agree that such orders may be placed by the guest on behalf of the host, but in such case BA must be provided with an acceptable Letter of Authorization explicitly authorizing the guest to place such orders. Where an order is placed by the guest in conformity with this section BA will send bills for the ordered services to the guest, and will

accept payments from the guest on the COR's account. Notwithstanding such ordering and billing arrangements, the obligation to pay BA for such services remains exclusively with the COR, regardless of whether the guest complies with its obligations under its contract with the COR to make payments to the COR or to BA. BA may pursue any available rights and remedies against the COR in the event of non-payment, without first seeking payment from the guest, regardless of whether the services for which payment is due are being used by the COR or by the guest.

- (C) All terms and conditions for Physical Collocation as described in applicable Tariffs and in Section 13.0 of this Agreement will apply. In addition, the following terms and conditions will apply to shared cages:
- (1) The guest must be a CLEC.
 - (2) The host and guest must each be collocating for the purpose of interconnecting to BA or accessing BA's unbundled Network Elements.
 - (3) In its use of a Shared Cage, the guest must comply with the same BA rules and regulations and municipal/zoning regulations as are applicable to the COR.
 - (4) The COR assumes the responsibility for the guest's violation of all Tariff regulations and other requirements related to a Shared Cage arrangement, and will be liable for any damage or injury to BA caused by the conduct of the guest, to the same extent as the COR would be liable if it had engaged in such conduct itself. The COR will also indemnify BA against any third-party claims resulting from the guest's conduct, to the same extent as it would be responsible for such indemnification if it had engaged in such conduct itself.
 - (5) The host and guest will participate in Method of Procedure (MOP) meetings detailing the installation work to be performed by the guest. This shall be completed for all Physical Collocation equipment installation. The host shall prominently display the signed MOP at the multiplexing node while any installation functions are performed.
 - (6) The host must provide BA's designated representative(s) with a list of the names of all technicians who will need access to the Shared Cage for support, maintenance and repair purposes. The host is responsible for supplying such representative(s) with the required completed non-employee ID badge application forms and all appropriate identification material for its employees/agents as well as those of the guest.
 - (7) BA will issue only one identifying cage and POT Bay CLLI code and provide it to the host. The host will assume connecting facility assignment (CFA) responsibilities.
 - (8) All occupancy and specific cage construction communications (e.g., cage augments, cage access or deployment requirements) will be between the host and BA as specified in this Agreement.
 - (9) The host will remain responsible for all costs associated with the cage (e.g., cage construction, POT Bay installation). BA will not split bill any of the rate elements associated with the Collocation cage between the host and its tenant (e.g., recurring square foot charges, power, cable racking).

This Amendment becomes effective upon signature by each of the Parties, and may be executed in counterparts.

NEW YORK TELEPHONE
COMPANY

COVAD
COMMUNICATIONS CO.

By: *Jeffrey A. Masoner* By: *Dhruv Khanna*

Printed: Jeffrey A. Masoner

Printed: DHRUV KHANNA

Title: Vice President - Interconnection
Services Policy & Planning

Title: V.P. - General Counsel

Date: 12/9/98

Date: 12/4/98