



---

---

**STREET LIGHTING  
POLE ATTACHMENT AGREEMENT**

**BETWEEN**

**ROCHESTER GAS AND ELECTRIC**

**AND**

**TOWN OF HENRIETTA**

**NEW YORK**

---

---

**Dated: March 8, 2023**

## **STREET LIGHTING POLE ATTACHMENT AGREEMENT**

THIS AGREEMENT, made as of the 8th day of March, 2023, between ROCHESTER GAS AND ELECTRIC CORPORATION , (hereinafter designated as “RGE”) a corporation organized and existing under the laws of the State of New York, having an office at 180 S. Clinton Ave, County of Monroe, State of New York, 14604, and TOWN OF HENRIETTA, a duly organized municipal corporation of the State of New York having an office at 475 Calkins Road, Rochester New York 14623, hereinafter called “Town” or “Licensee”. RGE and the Licensee are collectively referred to herein as the “Parties” or individually as a “Party.”

### **WITNESSETH:**

WHEREAS, Licensee for its own use desires to attach and maintain its streetlight equipment, facilities and attachments with necessary guys and appurtenances on RGE Poles; and

WHEREAS, RGE is willing to permit, to the extent it may lawfully do so, the placement of said streetlight equipment, facilities and attachments on its Poles as specified herein; and

WHEREAS, RGE owns and has for many years operated and maintained an electric distribution system, including street lighting poles, luminaries and lamps, mast arms, electrical connections, and wiring for street lighting installed throughout the Town limits; and

WHEREAS, the Town has facilities and attachments throughout the Town limits, hereafter collectively described as the “Licensee’s Facilities”, which are currently installed on RGE’s Poles; and

WHEREAS, it is the agreement of the parties that the Licensee’s Facilities shall continue to be attached to the Poles following the purchase of such Facilities; and

NOW, THEREFORE, in consideration of the mutual covenants, terms and conditions herein contained, the parties do hereby mutually covenant and agree as follows:

### **ARTICLE I DEFINITIONS**

As used in the Agreement:

Section 1.01 “Applicable Laws” mean the Communications Act of 1934, as amended (47 U.S.C.'224 et seq.) and any and all implementing legislation, the law of New York State, New York Public Service Commission regulations, rules, and orders, and Federal Communications Commission regulations, rules, and orders now in effect or as may hereafter be modified or amended to the extent the same relate to pole attachments. Nothing in this definition shall be construed as to limit or affect in any way the Governing Law provisions set forth in Article XI of this Agreement.

Section 1.02 “Attachment” means any of the following:

- Equipment mounted in the usable space which precludes that space from being utilized by a single messenger span wire facility. Each preclusion will be counted as a separate attachment.
- Equipment mounted in non-usable or other than usable space which precludes that space

from being utilized by RGE, a Joint User or another third party.

Section 1.03 “Facilities” means streetlight facilities and wires.

Section 1.04 “Joint Owner” means any other public utility which shall now or thereafter have joint or shared ownership of any of RGE’s Poles. The term “Joint Owner” shall not include the Licensee.

Section 1.05 “Joint User” means any public utility or municipality or any subdivision or agency thereof which shall now or hereafter have the right to use any of Licensor’s poles. The term “Joint User” shall not include licensees with limited attachment rights such as those accorded Licensee hereunder.

Section 1.06 “Licensee” shall mean any person, other than a Joint User, who now or hereafter has any attachment or other rights with respect to Licensor’s occupying of said poles.

Section 1.07 “Licensee’s Facilities” means the Facilities and all associated equipment and hardware owned or controlled by the Licensee.

Section 1.08 “Make Ready Work” shall mean all work necessary to accommodate proposed attachments of Licensee including but not limited to pre-construction surveys and rearrangements or changes in the Facilities of Licensor, Joint Users or other Licensees.

Section 1.09 “Other Than Usable Space” means that space other than the Usable Space (the space above the minimum grade level which can be used for the attachment of wires, cables, and associated equipment) on a pole.

Section 1.10 “Pole Attachment” means any of Licensee’s Facilities in direct contact with or otherwise supported by a utility pole, duct, conduit, or right-of-way owned or controlled, wholly or partially, by RGE.

Section 1.11 “Rental”, “Rental Fees” and “Pole Rental” means the Pole Attachment Change as defined in RGE’s Streetlight Tariff.

Section 1.12 “RGE’s Poles” or “Poles” means poles wholly or partially owned by RGE.

Section 1.13 “Usable Space” means the total space on the utility pole above the minimum grade level that is usable for the attachment of wires, cables, and related equipment.

## **ARTICLE II GENERAL PROVISIONS**

- (a) The Town may keep and maintain its Licensee Facilities on RGE’s Poles in accordance with this Agreement, and RGE hereby grants a license to the Town relative to the same.
- (b) Scope of rights. The right granted pursuant to this Agreement to attach and maintain Licensee Facilities is to be exercised by the Licensee subject to any and all governmental regulations now or hereafter in force and in such manner as shall not interfere with RGE’s use and maintenance of RGE’s Poles, wires and property thereon.
- (c) No assignment. The Licensee shall not in any way assign, transfer, sublet, or encumber this Agreement, nor any of the rights or privileges hereby granted by it, without the prior written consent of RGE, which consent shall not be unreasonably withheld or delayed. Any attempted assignment, transfer, sublease, or encumbrance without such prior written consent is void. Subject to the foregoing, however, this Agreement shall extend to and bind the

successors and assigns of the parties hereto. In addition, the Licensee shall not, in any manner, extend any of the rights or privileges to access, install, and/or maintain its Facilities on RGE's Poles granted under this Agreement to any other entity, affiliated or otherwise, without the prior written consent of RGE.

- (d) Notices. All notice required under this Agreement, shall be made pursuant to this Section. Notice under this Agreement must be in writing and effective at least ten days before the action or non- action by RGE. Notices are effective upon receipt.

Notice should be sent to the following addresses:

For RGE: Laura B. Read-Siedlecky  
RGE/RG&E  
Joint Use of Plant  
P.O. Box 5224  
Binghamton, New York 13902-5224

Copy to:  
Rochester Gas and Electric Corporation  
Attn: Legal Department  
180 S. Clinton Avenue, 5<sup>th</sup> Floor  
Rochester, New York 14604

For Licensee: Town Supervisor  
Town of Henrietta  
475 Calkins Road  
Rochester New York 14623

(e) No prior agreements. This Agreement supersedes all previous agreements between the parties for attachment of Licensee's Facilities to RGE's Poles.

(f) No ownership. No use, however extended, of RGE's Poles or payment of any fees or charges required under this Agreement shall create or vest in Licensee any ownership or property rights in RGE's Poles or anchors, and Licensee's rights therein shall be or remain a mere license. Nothing herein contained shall be construed to compel RGE to construct, retain, extend, place or maintain any Facilities not needed for its own service requirements, except for rearrangements and replacements covered under Article VII of this Agreement.

It is recognized by the Licensee that RGE has heretofore entered into, or may in the future enter into, agreements and arrangements with others not a party to this Agreement regarding the Poles covered by this Agreement. Nothing herein contained shall be construed as a limitation, restriction or prohibition against RGE with respect to such other agreements and arrangements so long as such agreements and arrangements do not interfere with the Towns' ability to reasonably maintain and operate its Licensee Facilities on RGE's Poles. So long as there is no such interference, the attachment privileges herein granted shall at all times be subject to such agreements and arrangements.

(g) No waiver. Failure to enforce or insist upon compliance with any of the terms or conditions of this Agreement shall not constitute a general waiver or relinquishment of any such terms or conditions, but the same shall be and remain at all times in full force and effect.

(h) Severability. If any provision of this Agreement is unenforceable under any applicable law or is held invalid, such shall not affect any other provision hereof, and this Agreement shall be construed as if such unenforceable or invalid provision had never been contained herein.

(i) Existing Facilities as of Effective Date. For those Licensee Facilities identified in the Sales

Agreement between RGE and the Town and already attached to Poles as of the Effective Date, no further approval under this Agreement shall be required for such attachments. RG&E reserves the right to require repairs to such facilities and Licensee is required to submit service applications for any upgrade that materially changes the character of said facilities consistent with Art IV(c).

### **ARTICLE III APPLICATION FOR PERMISSION TO ATTACH**

Forty-five (45) days prior to when the Licensee wishes to make additional attachments to RGE's Poles, the Licensee shall make written application to their respective RGE Streetlight Representative by means of the Streetlight Request Form marked "Exhibit A" or superseding versions, attached hereto, specifying the type of facility and the location of the Poles. RGE will indicate its approval by returning one copy of the Streetlight Request Form to the Licensee bearing its written consent, consent shall not be unreasonably withheld. This written consent will be designated as a "Licensee."

### **ARTICLE IV RENTAL AND OTHER CHARGES**

For attachments of Licensee's Facilities to RGE's Poles, the Licensee shall pay RGE rental and other changes as follows:

(a) **Billing Periods:** For the attachment of Licensee's Facilities, a Monthly Pole Attachment Charge, per mast arm, will be charged as defined in RGE's Streetlight Tariff.

(b) **Periodic Inspections and Surveys:** If, as a result of a periodic inspection, it is determined that the Licensee has made unauthorized attachments to RGE's Poles, the Licensee shall pay RGE back rental from the time the attachment was made. If the time of attachment cannot be determined, the Licensee shall pay RGE an amount equal to the annual rate times the number of years since the last periodic inspection, up to a maximum of five years. Periodic inspections, at the Licensee's expense, may be performed every five years or less frequently at RGE's discretion. More frequent inspections may be performed if the Licensee's performance does not meet prescribed regulatory thresholds. If it is found that Licensee's attachments do not meet the standards outlined in Article V of this Agreement, then RGE may, at its option, conform the attachments and Licensee is liable for all costs incurred relating to such conforming, notwithstanding the notice provision of Article V(a) of this Agreement.

RGE reserves the right to make periodic surveys and inspections of all or any part of Licensee's Facilities on RGE's Poles and of any other facilities in the vicinity of Licensee's Facilities at the expense of Licensee.

(c) **Make-Ready:** Work required to be performed prior to, and because of, attachment of new/enlarged/moved Licensee Facilities, including, but not limited to the pre-construction survey, rearrangement of existing equipment, guying and anchoring, pole replacements, construction inspections, and post construction inspections shall be referred to as Make-Ready. Similar work required after initial attachment to a Pole shall be referred to as Additional Make-Ready. RGE shall notify the Town of any proposed Make-Ready Work and shall bill the Town for such work. Work related to those Licensee Facilities present on Poles as of the date of this Agreement shall not comprise Make Ready or Additional Make Ready work so long as such work results in like-kind License Facilities (e.g., such Facilities are not materially enlarged, only the fixture head is replaced, etc.). The Town shall reimburse RGE for Make-Ready work within thirty (30) days from receipt of an RGE invoice or issuance of a Town purchase order to RGE. When RGE employs an outside contractor rather than its own work forces to perform Make-Ready, Licensee shall pay an amount equal to the contractor's fees plus an administration fee to cover the cost of supervision, accounting, and support services. RGE shall make available copies of all written contracts, agreements, understandings, and work orders pertinent to Make-Ready work.

(d) **Billing Due Dates:** Unless otherwise indicated by RGE, all bills for rental and other charges are payable by the Licensee by the due date indicated on the Bill, which shall not be less than thirty (30) days from the Town's receipt of the invoice.

## **ARTICLE V SPECIFICATIONS**

(a) **Codes and Rules:** The Licensee, its agents, employees, servants and contractors, must meet all requirements of the National Electrical Safety Code (NESC), the Occupational Safety and Health Administration (OSHA), RGE Standards marked "Exhibit B" or superseding versions, attached hereto, RGE and other relevant safety standards for proper bonding, grounding, clearances, guying, anchoring and installing of Licensee's Facilities. The Licensee, its agents, employees, servants and contractors must also meet all local licensing requirements. If Licensee's attachments do not conform to these requirements, RGE may require the Licensee to correct the condition and if the Licensee does not do so after three (3) months' notice, or such other time period specified in the notice, RGE may perform the work and the Licensee is liable for all costs thereto. In the event of an emergency, RGE may, at its option, correct the condition without prior notice to Licensee, and Licensee is liable for all costs thereto. RGE reserves the right, at all times, to specify the type and methods of design, construction and maintenance of Licensee's attachments on RGE's Poles in order to protect its Poles, so long as reasonably consistent with generally accepted practices and industry standards.

(b) **Inspections:** RGE may require the Licensee to advise it, on a day-to-day or week-to-week basis, of the exact locations where Licensee's Facilities are being constructed. RGE may conduct frequent inspections of Licensee's construction in progress in lieu of or in addition to traditional post-construction surveys, and at the Licensee's expense. The costs may be included as part of the Make-Ready billing.

(c) **Equipment:** Prior written permission must be granted by RGE and Joint Owners before the Licensee may attach any equipment to RGE's Poles, which shall not be unreasonably withheld. RGE and Joint Owners will determine if the poles are of suitable strength to accommodate the Licensee's equipment. Requests for such permission, and notice of such permission or denial of permission, must be done in accordance with Article III of this Agreement.

## **ARTICLE VI GOVERNMENTAL AUTHORITY AND EASEMENTS**

(a) **Governmental Authority:** Before making any attachments to RGE's Poles, the Licensee must obtain any necessary permits or consents from federal, state, and/or municipal authorities and shall comply with all laws, rules and regulations. No guarantee is given by RGE of permission by municipalities or others respecting the use of its Poles by the Licensee.

(b) **Easements:** Where RGE has an easement over a public or private right-of-way sufficiently broad under New York State law to permit streetlight attachments, Licensee shall not be required to obtain independent permission of the property owner to attach. Upon request RGE shall make available to Licensee copies of all relevant recorded easements, with the Licensee bearing the cost of providing such information. Where RGE seeks to obtain any necessary permission from a property owner for Licensee's attachments, the fully allocable costs of such efforts shall be paid by the Licensee. Moreover, the Licensee will exercise due care when upon landowners property, and take reasonable steps to inform landowners prior to making any attachments to or tree trimming around RGE's Poles. No guarantee is given by RGE of permission by property owners respecting the use of any easement.

## **ARTICLE VII INITIAL RE-ARRANGEMENTS AND POLE REPLACEMENTS**

(a) **Make-Ready Defined:** Upon receipt of an application for a pole license, RGE will determine the approximate cost of performing the pre-construction engineering, shall notify Licensee of such amount,

and shall make appropriate surveys of the Poles listed with a representative of the Licensee, Joint Owner, and any other third parties. RGE shall determine, among other things, whether, in order to accommodate the attachments of the Licensee, any rearrangements or changes are necessary in RGE Facilities or of other Joint Owners or other third parties with attachment rights. In addition, the joint survey shall determine whether any Poles require strengthening (guying and anchoring), whether any Poles require replacement, and whether the Licensee's strand and equipment need to be bonded or grounded to RGE Facilities or other users. The Town will have the opportunity to review the estimated cost and either agree to proceed with the Work or decline. If the Town agrees to proceed, all such work and other work required in connection with accommodating Licensee's Facilities, including preconstruction engineering and a post-construction inspection, will be considered as Make-Ready work. Make-Ready work shall not include replacement in kind of Licensee Facilities, in the materially same location, such as upgrading fixtures to LEDs.

(b) **Make-Ready Billing:** After completion of the pre-construction engineering, RGE will notify the Licensee about all Make-Ready work to be performed. The Licensee shall pay the bill for such work within thirty (30) days from receipt of an RGE invoice or issuance of a Town purchase order to RGE. Licensee is liable for additional costs related to the Make-Ready work incurred by RGE, notwithstanding any prior billing or Make-Ready work already done by RGE.

(c) **Make-Ready Timing:** RGE will meet a reasonable schedule for the performance of Make-Ready work, subject to sixty (60) days' notice and further subject to the primary priority of power delivery service obligations. If RGE or multiple applications are received from the Licensee or Licensees, requiring more Make-Ready work than can be reasonably handled by the operating office, then RGE shall endeavor to allocate its available work forces, as far as practical, to accommodate the needs of the Licensee or of other Licensees. Once Make-Ready work has been completed, RGE will inform the Licensee, Joint Owner and any other third parties. Applicable Licenses will then be issued.

## **ARTICLE VIII POLE RELOCATIONS AND REPLACEMENTS**

It is the responsibility of the Licensee to relocate, replace or transfer its facilities in accordance with RGE's Streetlight Tariff.

## **ARTICLE IX INDEMNIFICATION, INSURANCE AND LIABILITY**

(a) **Damage to RGE:** The Licensee shall indemnify, hold harmless, and defend RGE from and against any and all liabilities, losses, damages, costs, suits, judgments, claims, demands, penalties, and expenses of every name and description to which RGE may be subjected arising out of damage to any property, including loss of rights-of-way, property owners' consents and/or the cost of defending such rights, or injury to or death of any person or persons, directly or indirectly caused by, in any manner connected with, or attributed to, the actions or omissions of the Licensee, or any of its employees, servants, agents, contractors in the course of using, operating, handling, placing, connecting, working on, maintaining, repairing, replacing and/or removing its Facilities covered by this Agreement.

(b) If Licensee, while exercising due care, in the course of using, operating, handling, placing, connecting, working on, maintaining, repairing, replacing and/or removing its Facilities covered by this Agreement, in any way damages the facilities of the RGE, Licensee shall not be liable to RGE for any claim for indirect, consequential, exemplary, special, incidental, or punitive damages, including without limitation, loss of use or lost business, revenue, profits or goodwill, arising in connection with this Agreement, under any theory of tort, contract, warranty, strict liability or negligence. The Licensee shall indemnify, save harmless and defend RGE from and against any and all claims related thereto by a subscriber or customer of the Licensee.

(c) **Damage to Licensee:** If RGE, while exercising due care, in the course of using, operating, handling, placing, connecting, working on, maintaining, repairing, replacing and/or removing its facilities covered by this Agreement, in any way damages the Facilities of the Licensee, RGE shall

not be liable to the Licensee for any claim for indirect, consequential, exemplary, special, incidental, or punitive damages, including without limitation, loss of use or lost business, revenue, profits or goodwill, arising in connection with this Agreement, under any theory of tort, contract, warranty, strict liability or negligence. The Licensee shall indemnify, save harmless and defend RGE from and against any and all claims by a subscriber or customer of the Licensee.

The total liability of RGE to Licensee shall be limited to direct damages proven by Licensee. Notwithstanding anything to the contrary herein, to the fullest extent permitted by law, RGE shall not be liable, whether arising out of contract, tort, strict liability, or any other cause or form of action, for loss of anticipated profits, service interruptions, or for any special, incidental, punitive, indirect or consequential loss or damages resulting in any way from this Agreement or the performance of the services hereunder, even if advised of the possibility of such damages.

(d) The Town is insured and will provide RGE proof of insurance. Upon request, the Town will provide proof of insurance to any Joint Owner.

(e) **Damage Report:** The Parties shall exercise reasonable care to avoid causing damage to each other's facilities, those of Joint Owners, and/or other third parties, on said Poles; and hereby assume all responsibility for any and all out of pocket costs directly attributable to a respective Party, except as otherwise set forth herein. The Parties shall make an immediate report to one another of said occurrence of any damage and hereby agrees to reimburse the other respective Party, Joint Users, and/or other third parties for the expense incurred in making repairs.

(f) **Force Majeure:** Neither Party shall be held liable for any delay or failure in performance of any part of this Agreement, other than failure to pay monies due or owed, to the extent that such failure or delay is caused by acts of God, acts of civil or military authority, government regulations, embargoes, epidemics, war, terrorist acts, riots, insurrections, fires, explosions, earthquakes, nuclear accidents, floods, strikes, power blackouts, volcanic action or other environmental disturbances, unusually severe weather conditions, inability to secure products or services of other persons or transportation facilities, acts or omissions of transportation or common carriers, or causes beyond the control of the Party. If any Force Majeure condition occurs, the Party delayed or unable to perform shall give immediate notice to the other Party and shall take reasonable steps to correct the Force Majeure condition. During the pendency of the Force Majeure, the duties of the Parties under this Agreement affected by the Force Majeure condition, other than the obligation to make Rental payments hereunder, shall be abated and shall resume without liability thereafter.

## **ARTICLE X TERM AND TERMINATION OF AGREEMENT**

(a) **Term:** This Agreement shall continue in effect for a term of ten (10) years from the date hereof, and will continue thereafter until terminated as provided herein. This Agreement, if not previously terminated in accordance with Article X (b), may be terminated at the end of said time or at any time thereafter by either party giving to the other party at least six (6) months prior written notice.

(b) **Termination:** RGE may terminate the Agreement immediately upon notice to Licensee if RGE is unable to obtain any governmental license, waiver, consent, registration or approval necessary to perform its obligations. RGE may not terminate this agreement in totality if Partial Reduction (defined below in (c)) resolves the aforementioned issues, so long as the Town agrees to Partial Reduction in lieu of termination. If Licensee fails to comply with any of the provisions of this Agreement or defaults in any of its obligations under this Agreement, RGE may, at its option, terminate this Agreement in its entirety, or require the Licensee to remove its attachments from the Pole or Poles involved in the default or non-compliance, but only after reasonable notice to Licensee and a reasonable opportunity to cure. Termination of this Agreement does not release or affect in any way any liability or obligation of the Licensee pursuant to the terms of this Agreement and such liability survives the termination of this Agreement. If Licensee fails to remove its Facilities within six (6) months after notice

of termination of this Agreement or cancellation of any licenses, RGE shall remove Licensee's Facilities, at Licensee's expense and without incurring any liability for damage to or destruction of said Facilities so long as completed with reasonable care. Prior to terminating or revoking any license under this Agreement, or the Agreement itself, for whatever cause or purpose, a petition may be brought by either party to the New York Public Service Commission (the "Commission") requesting the Commission to decide the dispute. A filing with the Commission contesting the termination and/or removal of Licensee's facilities pursuant hereto shall toll the time for any removal obligation hereunder. A Commission determination shall be binding on all parties to this Agreement.

(c) Partial Reduction. In lieu of termination of the entirety of this Agreement, partial extinguishment of some of Licensee's license rights, such as with respect to a particular Pole or Poles, may be exercised such that the entire Agreement is not terminated and instead Licensee's license rights are reduced or terminated only with respect to certain specific Poles ("Partial Reduction"). To the extent feasible, this Agreement shall not be terminated in its entirety where instead RGE may reasonably achieve its goals via Partial Reduction. Licensee's fees, costs and liabilities hereunder shall be reduced consistent with any such Partial Reduction. In the event of any contemplated Partial Reduction, the Licensee shall have the option to elect complete termination in lieu thereof.

(d) Removals: Licensee may at any time remove its attachments from RGE's Poles and thus terminate this Agreement, but shall immediately give written notice to RGE by means of the Streetlight Request Form substantially in the form of "Exhibit A" attached hereto. No credit or refund of any Rental changes shall be allowed the Licensee on account of such removal. Licensee may also at any time remove some or any of its attachments from any of RGE's Poles and thus terminate or surrender a portion of its license rights under this Agreement with specific respect thereto, with a corresponding reduction in fees, and with the remainder of its license rights and this Agreement surviving and continuing, but in such an event shall immediately give written notice to RGE

## **ARTICLE XI GOVERNING LAW**

This Agreement shall be construed, interpreted and governed in accordance with the laws, ordinances and regulations of the State of New York, without regard to its conflicts of law's provisions.

## **ARTICLE XII AMENDMENTS**

This Agreement may only be modified, amended or supplemented by an instrument in writing signed by both parties.

## **ARTICLE XIII SEVERABILITY**

If any provision of this Agreement is rejected or held to be illegal, invalid or unenforceable, the validity, legality and enforceability of the remaining provisions of this Agreement shall not be affected or impaired thereby. If a provision that is rejected or held to be illegal, invalid or unenforceable is material to carry out the intent of this Agreement, the parties shall negotiate in good faith an amendment to this Agreement to replace the unenforceable language with enforceable language.

## **ARTICLE XIV COUNTERPARTS**

This agreement may be executed in one or more counterparts, all of which taken together shall constitute one and the same instrument.

**IN WITNESS WHEREOF**, the parties hereto have caused this Agreement to be executed in duplicate by the duly authorized officers as of the day and year first above written.

ROCHESTER GAS AND ELECTRIC CORPORATION (Business Signature)

By:  Date: April 11, 2023  
Patricia Nilsen  
President and Chief Executive Officer

ROCHESTER GAS AND ELECTRIC CORPORATION (Control Signature)

By:  Date: April 11, 2023  
Andrea VanLuling  
Controller, and Treasurer (Control)

TOWN OF HENRIETTA

By:  Date: 3/9/2023  
Title: TOWN SUPERVISOR

# EXHIBIT A

## Streetlight Request Form

## Service Class 2 - Energy Only



### Customer Information

Municipality Name	RG&E Account #
Authorized Representative	Contact Telephone Number

### RG&E Connection Point

<input type="checkbox"/> Connect <input type="checkbox"/> Disconnect <input type="checkbox"/> Existing <input type="checkbox"/> Reconnect	Overhead - Pole #	Underground - Manhole/Handhole #	Secondary power available at location? <input type="checkbox"/> Yes <input type="checkbox"/> No
Description of Location for Connection Point			

### Lamps ( fill out one line for each luminaire)

	Street Name	Pole #	Wattage (incl. ballast)	Lamp Type	Arm attached to RG&E Pole?
<input type="checkbox"/> Install <input type="checkbox"/> Remove					
<input type="checkbox"/> Install <input type="checkbox"/> Remove					
<input type="checkbox"/> Install <input type="checkbox"/> Remove					
<input type="checkbox"/> Install <input type="checkbox"/> Remove					
<input type="checkbox"/> Install <input type="checkbox"/> Remove					
<input type="checkbox"/> Install <input type="checkbox"/> Remove					
<input type="checkbox"/> Install <input type="checkbox"/> Remove					
<input type="checkbox"/> Install <input type="checkbox"/> Remove					
<input type="checkbox"/> Install <input type="checkbox"/> Remove					
<input type="checkbox"/> Install <input type="checkbox"/> Remove					
<input type="checkbox"/> Install <input type="checkbox"/> Remove					
<input type="checkbox"/> Install <input type="checkbox"/> Remove					
<input type="checkbox"/> Install <input type="checkbox"/> Remove					
<input type="checkbox"/> Install <input type="checkbox"/> Remove					
<input type="checkbox"/> Install <input type="checkbox"/> Remove					
<input type="checkbox"/> Install <input type="checkbox"/> Remove					
<input type="checkbox"/> Install <input type="checkbox"/> Remove					
<input type="checkbox"/> Install <input type="checkbox"/> Remove					
<input type="checkbox"/> Install <input type="checkbox"/> Remove					

### Project Notes

Authorized Representative	Signature	Date	Title

Additional instructions and information is provided on the back of this form.

For RG&E use only			
Installation:	Received:	SN:	CCS Updated:

## **EXHIBIT B**

### **1.0 General Notes for Energy Only Street Lighting**

1. As per tariff, the customer will be charged for connection and disconnection.
2. The customer will install ownership identification on all Energy Only poles. The identification will be decided upon by the municipality and agreed to by the Company.
  - a. The customer will determine a pole tagging convention that is convenient for them and submit it to the Company.
  - b. The Company will agree or make changes and work with the municipality to determine a final identification.
  - c. Once the identification is agreed upon, the location will be as follows:
    - i. NYSEG/RGE owned pole – identification will be placed below the NYSEG/RGE pole Identification at a minimum of 5' above ground.
    - ii. The identification tag should not be more than 3 inches tall by 6 inches wide.
3. The customer shall identify the lamp per ANSI standard C136.15-2009.
4. The NYSEG /RGE approved in-line disconnects are listed in the table below.
  - a) Homac SLK-3A (#14 - #6 str or solid wire)
  - b) Homac SLK-M (#12 - #4 str or solid wire)
5. Conduit shall be rigid galvanized steel or Schedule 80 PVC.
6. Customer to have all work performed by qualified workers following OSHA regulations, the National Electric Safety Code, Company specifications and local electrical codes.

### **2.0 Underground Supplied Fixture From an Underground Service Point**

1. The customer will install a pull box within 50' of NYSEG/RGE's manhole, handhole or padmount designated as the point of service.
2. The customer will extend a conduit from the pullbox to NYSEG's/ RGE's MH/HH/PM. NYSEG / RGE will break into and seal conduit entrance into NYSEG / RGE MH/HH/PM.
3. Customer will supply a 200 lb. nylon pull cord for pulling supply conductors into NYSEG /RGE MH/HH/PM. NYSEG / RGE will assist with the entry in MH/HH/P and pull the rope and leave coiled for future cable pull. Refer to note 5 for cable pulling in NYSEG /RGE MH/HH/PM.
4. Customer will install a current limiting in-line disconnect device in customer H.H. and will supply sufficient length of supply conductors coiled in H.H. to reach center of NYSEG / RGE MH/HH/P. Refer to note 5 for cable pulling in NYSEG / RGE MH/HH/PM.

5. NYSEG / RGE will pull supply conductors into NYSEG / RGE MH/HH/PM and connect. A solid unbreakable connection will be made between NYSEG/ RGE and customer conductors.
6. A tariff option allows a single fixture to be connected directly without a customer H.H. if the pole is within 50' from the NYSEG / RGE MH/HH/PM and there is sufficient room in base for a current limiting in-line disconnect device and coiled supply conductors.

Note: If the customer elects to install an approved direct buried cable, the cable should be left coiled and protected at the outside wall of NYSEG's/ RGE's MH/HH/PM.

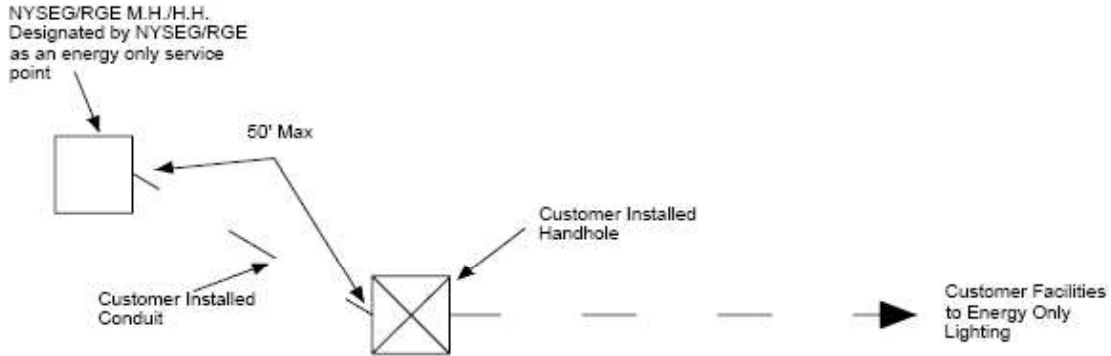

**Figure 1: Underground Supplied Fixture from Underground Supply Point**

### **3.0 Underground Supplied Fixture from an Overhead Service Point**

1. Customer will install 10' conduit riser on pole. Metal risers will be installed with appropriate grounds.
2. Location of riser to be directed by NYSEG / RGE.
  - a. Pole identification tags should not be covered.
  - b. Care should be taken to allow room for linemen to climb pole.
3. Customer will install a current limiting in-line disconnect device 5' above the riser with sufficient cable to reach NYSEG / RGE secondary plus 48".
4. NYSEG / RGE will make connections to the secondary facility.

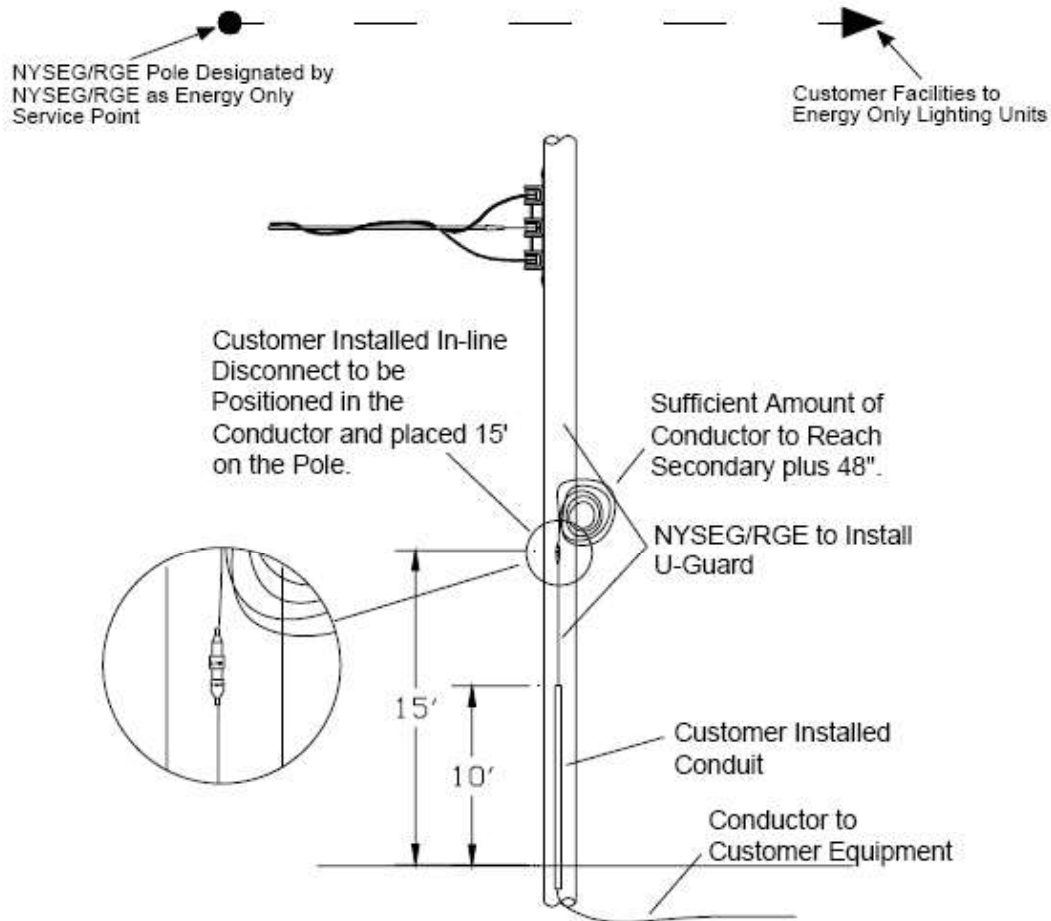

**Figure 2: Underground Supplied Fixture From Overhead Service Point**

#### **4.0 Overhead Supply Point to Overhead Fixture**

1. The customer will install conductors and a bonding conductor (#6 copper minimum) of sufficient length plus 48" to reach NYSEG E's/ RGE's secondary facilities on the pole.
2. The customer will mount the current limiting in-line disconnect device at the bracket pole plate and connect the bonding wire to the bracket.
3. NYSEG / RGE will make connections to the secondary facility.

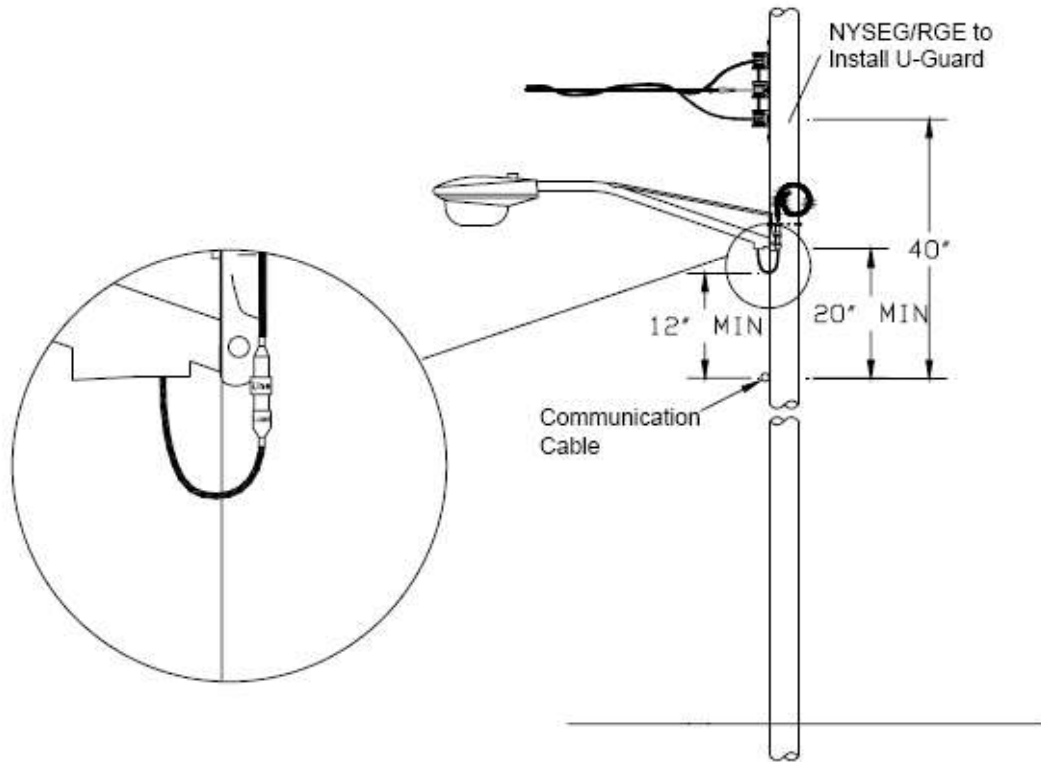

**Figure 3: Overhead Supply Point to Overhead Fixture**

### **5.0 Customer Installed Overhead Conductor to an Overhead Service Point**

1. Customer will bring overhead conductor to NYSEG / RGE service point pole and suspend the conductor from a customer installed clevis or the Company clevis or service rack if permission is given. The conductor will be of sufficient length to reach NYSEG's/ RGE's secondary facilities on the pole plus 48".
2. Customer will include the current limiting in-line disconnect with the conductor.
3. NYSEG / RGE will make connections to the secondary facility.

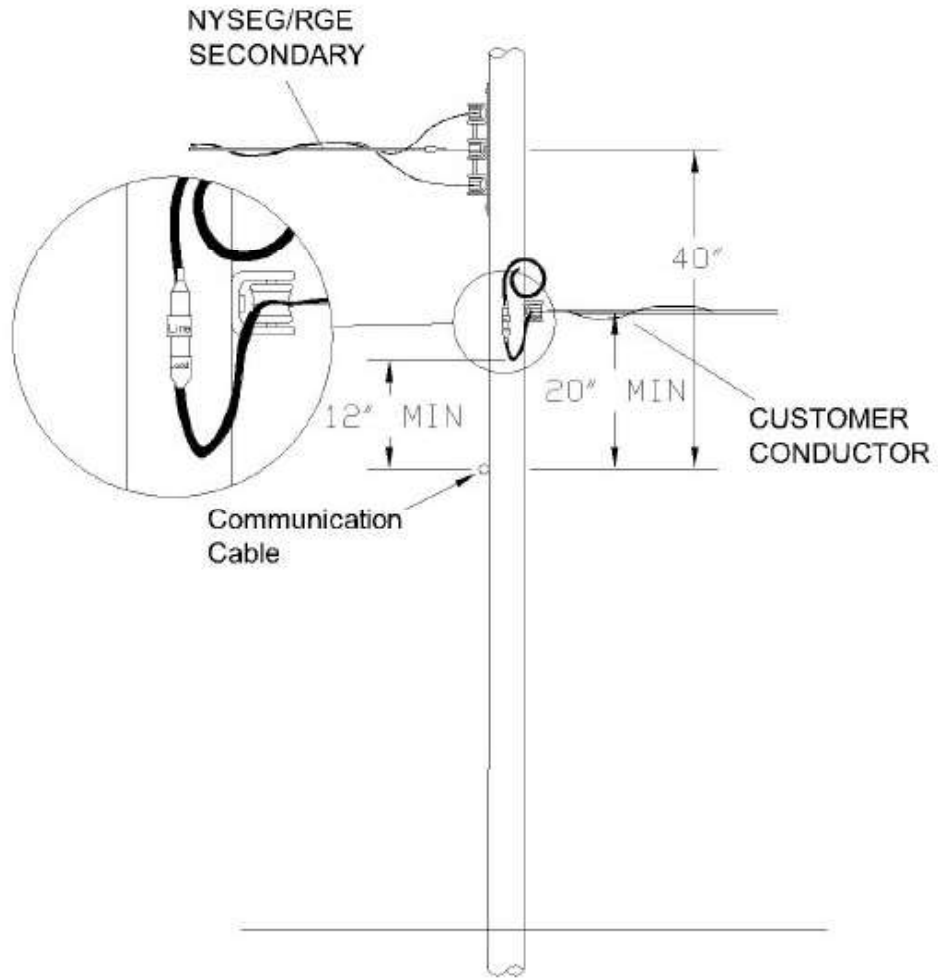

**Figure 4: Customer Installed Overhead Conductor to an Overhead Service Point**

**HAND HOLE LETTER WAIVER**