

**SERVICE AGREEMENT NO. 1774**

**AMENDED AND RESTATED  
INTERCONNECTION AGREEMENT  
AMONG THE  
NEW YORK INDEPENDENT SYSTEM OPERATOR, INC.  
AND  
NEW YORK POWER AUTHORITY  
AND  
MARBLE RIVER, LLC  
Dated as of June 13, 2012**

TABLE OF CONTENTS

	Page No.
<b>ARTICLE 1. DEFINITIONS</b> .....	<b>1</b>
<b>ARTICLE 2. EFFECTIVE DATE, TERM AND TERMINATION</b> .....	<b>11</b>
<b>2.1 Effective Date.</b> ....	<b>11</b>
<b>2.2 Term of Agreement.</b> ....	<b>11</b>
<b>2.3 Termination.</b> ....	<b>11</b>
<b>2.4 Termination Costs.</b> ....	<b>11</b>
<b>2.5 Disconnection.</b> ....	<b>12</b>
<b>2.6 Survival.</b> ....	<b>13</b>
<b>ARTICLE 3. REGULATORY FILINGS</b> .....	<b>13</b>
<b>3.1 Filing.</b> ....	<b>13</b>
<b>ARTICLE 4. SCOPE OF INTERCONNECTION SERVICE</b> .....	<b>13</b>
<b>4.1 Provision of Service.</b> ....	<b>13</b>
<b>4.2 No Transmission Delivery Service.</b> ....	<b>13</b>
<b>4.3 No Other Services.</b> ....	<b>14</b>
<b>ARTICLE 5. INTERCONNECTION FACILITIES ENGINEERING, PROCUREMENT, AND CONSTRUCTION</b> .....	<b>14</b>
<b>5.1 Options.</b> ....	<b>14</b>
<b>5.2 General Conditions Applicable to Option to Build.</b> ....	<b>15</b>
<b>5.3 Liquidated Damages.</b> ....	<b>17</b>
<b>5.4 Power System Stabilizers.</b> ....	<b>19</b>
<b>5.5 Equipment Procurement.</b> ....	<b>19</b>
<b>5.6 Construction Commencement.</b> ....	<b>19</b>
<b>5.7 Work Progress.</b> ....	<b>20</b>
<b>5.8 Information Exchange.</b> ....	<b>20</b>

<b>5.9</b>	<b>Limited Operation.</b>	<b>20</b>
<b>5.10</b>	<b>Developer’s Attachment Facilities (“DAF”).</b>	<b>20</b>
<b>5.11</b>	<b>Connecting Transmission Owner’s Attachment Facilities Construction.</b>	<b>21</b>
<b>5.12</b>	<b>Access Rights.</b>	<b>22</b>
<b>5.13</b>	<b>Lands of Other Property Owners.</b>	<b>22</b>
<b>5.14</b>	<b>Permits.</b>	<b>22</b>
<b>5.15</b>	<b>Early Construction of Base Case Facilities.</b>	<b>23</b>
<b>5.16</b>	<b>Suspension.</b>	<b>23</b>
<b>5.17</b>	<b>Taxes.</b>	<b>24</b>
<b>5.18</b>	<b>Tax Status; Non-Jurisdictional Entities.</b>	<b>29</b>
<b>5.19</b>	<b>Modification.</b>	<b>29</b>
<b>ARTICLE 6. TESTING AND INSPECTION</b>		<b>30</b>
<b>6.1</b>	<b>Pre-Commercial Operation Date Testing and Modifications.</b>	<b>30</b>
<b>6.2</b>	<b>Post-Commercial Operation Date Testing and Modifications.</b>	<b>31</b>
<b>6.3</b>	<b>Right to Observe Testing.</b>	<b>31</b>
<b>6.4</b>	<b>Right to Inspect.</b>	<b>31</b>
<b>ARTICLE 7. METERING</b>		<b>31</b>
<b>7.1</b>	<b>General.</b>	<b>31</b>
<b>7.2</b>	<b>Check Meters.</b>	<b>32</b>
<b>7.3</b>	<b>Standards.</b>	<b>32</b>
<b>7.4</b>	<b>Testing of Metering Equipment.</b>	<b>32</b>
<b>7.5</b>	<b>Metering Data.</b>	<b>32</b>
<b>ARTICLE 8. COMMUNICATIONS</b>		<b>33</b>
<b>8.1</b>	<b>Developer Obligations.</b>	<b>33</b>
<b>8.2</b>	<b>Remote Terminal Unit.</b>	<b>33</b>

8.3	No Annexation. ....	33
<b>ARTICLE 9. OPERATIONS.....</b>		<b>34</b>
9.1	General. ....	34
9.2	NYISO and Connecting Transmission Owner Obligations. ....	34
9.3	Developer Obligations. ....	34
9.4	Start-Up and Synchronization. ....	34
9.5	Real and Reactive Power Control. ....	34
9.6	Outages and Interruptions. ....	36
9.7	Switching and Tagging Rules. ....	40
9.8	Use of Attachment Facilities by Third Parties. ....	40
9.9	Disturbance Analysis Data Exchange. ....	40
<b>ARTICLE 10. MAINTENANCE.....</b>		<b>40</b>
10.1	Connecting Transmission Owner Obligations. ....	40
10.2	Developer Obligations. ....	41
10.3	Coordination. ....	41
10.4	Secondary Systems. ....	41
10.5	Operating and Maintenance Expenses. ....	41
<b>ARTICLE 11. PERFORMANCE OBLIGATION.....</b>		<b>41</b>
11.1	Developer Attachment Facilities. ....	41
11.2	Connecting Transmission Owner’s Attachment Facilities. ....	41
11.3	System Upgrade Facilities and System Deliverability Upgrades. ....	42
11.4	Special Provisions for Affected Systems. ....	42
11.5	Provision of Security. ....	42
11.6	Developer Compensation for Emergency Services .....	43
11.7	Line Outage Costs. ....	43

**ARTICLE 12. INVOICE.....43**

**12.1 General. ....43**

**12.2 Final Invoice .....43**

**12.3 Payment. ....43**

**12.4 Disputes. ....43**

**ARTICLE 13. EMERGENCIES .....44**

**13.1 Obligations. ....44**

**13.2 Notice. ....44**

**13.3 Immediate Action. ....44**

**13.4 NYISO and Connecting Transmission Owner Authority. ....44**

**13.5 Developer Authority. ....45**

**13.6 Limited Liability. ....46**

**ARTICLE 14. REGULATORY REQUIREMENTS AND GOVERNING LAW .....46**

**14.1 Regulatory Requirements. ....46**

**14.2 Governing Law.....46**

**ARTICLE 15. NOTICES .....46**

**15.1 General. ....46**

**15.2 Billings and Payments. ....47**

**15.3 Alternative Forms of Notice. ....47**

**15.4 Operations and Maintenance Notice. ....47**

**ARTICLE 16. FORCE MAJEURE.....47**

**16.1 Force Majeure. ....47**

**ARTICLE 17. DEFAULT .....48**

**17.1 Default.....48**

**ARTICLE 18. INDEMNITY, CONSEQUENTIAL DAMAGES AND INSURANCE.....48**

**18.1 Indemnity. ....48**

**SERVICE AGREEMENT NO. 1774**

**18.2 No Consequential Damages. ....50**

**18.3 Insurance. ....50**

**ARTICLE 19. ASSIGNMENT .....52**

**19.1 Assignment. ....52**

**ARTICLE 20. SEVERABILITY .....52**

**20.1 Severability. ....52**

**ARTICLE 21. COMPARABILITY .....53**

**21.1 Comparability. ....53**

**ARTICLE 22. CONFIDENTIALITY .....53**

**22.1 Confidentiality. ....53**

**ARTICLE 23. ENVIRONMENTAL RELEASES.....56**

**23.1 Developer and Connecting Transmission Owner Notice. . ....56**

**ARTICLE 24. INFORMATION REQUIREMENT .....56**

**24.1 Information Acquisition. ....56**

**24.2 Information Submission by Connecting Transmission Owner. ....57**

**24.3 Updated Information Submission by Developer. ....57**

**24.4 Information Supplementation.....57**

**ARTICLE 25. INFORMATION ACCESS AND AUDIT RIGHTS.....58**

**25.1 Information Access. ....58**

**25.2 Reporting of Non-Force Majeure Events. ....58**

**25.3 Audit Rights. ....59**

**25.4 Audit Rights Periods.....59**

**25.5 Audit Results. ....59**

**ARTICLE 26. SUBCONTRACTORS .....59**

**26.1 General. ....59**

**26.2 Responsibility of Principal. ....60**

**26.3 No Limitation by Insurance. ....60**

**ARTICLE 27. DISPUTES.....60**

- 27.1 Submission. ....60**
- 27.2 External Arbitration Procedures. ....60**
- 27.3 Arbitration Decisions. ....61**
- 27.4 Costs. ....61**
- 27.5 Termination. ....61**

**ARTICLE 28. REPRESENTATIONS, WARRANTIES AND COVENANTS.....61**

- 28.1 General. ....61**

**ARTICLE 29. MISCELLANEOUS .....62**

- 29.1 Binding Effect. ....62**
- 29.2 Conflicts. ....62**
- 29.3 Rules of Interpretation. ....62**
- 29.4 Compliance. ....63**
- 29.5 Joint and Several Obligations. ....63**
- 29.6 Entire Agreement. ....63**
- 29.7 No Third Party Beneficiaries. ....63**
- 29.8 Waiver. ....63**
- 29.9 Headings. ....64**
- 29.10 Multiple Counterparts. ....64**
- 29.11 Amendment. ....64**
- 29.12 Modification by the Parties. ....64**
- 29.13 Reservation of Rights. ....64**
- 29.14 No Partnership. ....64**
- 29.15 Other Transmission Rights. ....64**

**Appendices**

**AMENDED AND RESTATED STANDARD LARGE GENERATOR  
INTERCONNECTION AGREEMENT**

**THIS AMENDED AND RESTATED STANDARD LARGE GENERATOR INTERCONNECTION AGREEMENT** (“Agreement”) is made and entered into this 13<sup>th</sup> day of June, 2012, by and among Marble River, LLC, a limited liability corporation organized and existing under the laws of the State of Delaware (“Developer” with a Large Generating Facility), the New York Independent System Operator, Inc., a not-for-profit corporation organized and existing under the laws of the State of New York (“NYISO”), and the New York Power Authority, a corporate municipal instrumentality organized and existing under the laws of the State of New York (“Connecting Transmission Owner”). Developer, the NYISO, or Connecting Transmission Owner each may be referred to as a “Party” or collectively referred to as the “Parties.”

**RECITALS**

**WHEREAS**, NYISO operates the Transmission System and Connecting Transmission Owner owns certain facilities included in the Transmission System; and

**WHEREAS**, Developer intends to own, lease and/or control and operate the Generating Facility identified as a Large Generating Facility in Appendix C to this Agreement; and,

**WHEREAS**, Developer, NYISO, and Connecting Transmission Owner have agreed to enter into this Agreement for the purpose of interconnecting the Large Generating Facility with the New York State Transmission System;

**NOW, THEREFORE**, in consideration of and subject to the mutual covenants contained herein, it is agreed:

**ARTICLE 1. DEFINITIONS**

Whenever used in this Agreement with initial capitalization, the following terms shall have the meanings specified in this Article 1. Terms used in this Agreement with initial capitalization that are not defined in this Article 1 shall have the meanings specified in Section 30.1.0 of Attachment X of the NYISO OATT or Attachment S of the NYISO OATT.

**Affected System** shall mean an electric system other than the transmission system owned, controlled or operated by the Connecting Transmission Owner that may be affected by the proposed interconnection.

**Affected System Operator** shall mean the entity that operates an Affected System.

## SERVICE AGREEMENT NO. 1774

**Affected Transmission Owner** shall mean the New York public utility or authority (or its designated agent) other than the Connecting Transmission Owner that (i) owns facilities used for the transmission of Energy in interstate commerce and provides Transmission Service under the Tariff, and (ii) owns, leases or otherwise possesses an interest in a portion of the New York State Transmission System where System Deliverability Upgrades or System Upgrade Facilities are installed pursuant to Attachment X and Attachment S of the Tariff.

**Affiliate** shall mean, with respect to a person or entity, any individual, corporation, partnership, firm, joint venture, association, joint-stock company, trust or unincorporated organization, directly or indirectly controlling, controlled by, or under common control with, such person or entity. The term “control” shall mean the possession, directly or indirectly, of the power to direct the management or policies of a person or an entity. A voting interest of ten percent or more shall create a rebuttable presumption of control.

**Ancillary Services** shall mean those services that are necessary to support the transmission of Capacity and Energy from resources to Loads while maintaining reliable operation of the New York State Transmission System in accordance with Good Utility Practice.

**Applicable Laws and Regulations** shall mean all duly promulgated applicable federal, state and local laws, regulations, rules, ordinances, codes, decrees, judgments, directives, or judicial or administrative orders, permits and other duly authorized actions of any Governmental Authority, including but not limited to Environmental Law.

**Applicable Reliability Councils** shall mean the NERC, the NPCC and the NYSRC.

**Applicable Reliability Standards** shall mean the requirements and guidelines of the Applicable Reliability Councils, and the Transmission District to which the Developer’s Large Generating Facility is directly interconnected, as those requirements and guidelines are amended and modified and in effect from time to time; provided that no Party shall waive its right to challenge the applicability or validity of any requirement or guideline as applied to it in the context of this Agreement.

**Attachment Facilities** shall mean the Connecting Transmission Owner’s Attachment Facilities and the Developer’s Attachment Facilities. Collectively, Attachment Facilities include all facilities and equipment between the Large Generating Facility and the Point of Interconnection, including any modification, additions or upgrades that are necessary to physically and electrically interconnect the Large Generating Facility to the New York State Transmission System. Attachment Facilities are sole use facilities and shall not include Stand Alone System Upgrade Facilities or System Upgrade Facilities or System Deliverability Upgrades.

**Base Case** shall mean the base case power flow, short circuit, and stability data bases used for the Interconnection Studies by NYISO, Connecting Transmission Owner or Developer; described in Section 30.2.3 of the Large Facility Interconnection Procedures.

## SERVICE AGREEMENT NO. 1774

**Breach** shall mean the failure of a Party to perform or observe any material term or condition of this Agreement.

**Breaching Party** shall mean a Party that is in Breach of this Agreement.

**Business Day** shall mean Monday through Friday, excluding federal holidays.

**Byway** shall mean all transmission facilities comprising the New York State Transmission System that are neither Highways nor Other Interfaces. All transmission facilities in Zone J and Zone K are Byways.

**Calendar Day** shall mean any day including Saturday, Sunday or a federal holiday.

**Capacity Region** shall mean one of three subsets of the Installed Capacity statewide markets comprised of Rest of State (Zones A through I), Long Island (Zone K), and New York City (Zone J).

**Capacity Resource Interconnection Service (“CRIS”)** shall mean the service provided by NYISO to interconnect the Developer’s Large Generating Facility to the New York State Transmission System in accordance with the NYISO Deliverability Interconnection Standard, to enable the New York State Transmission System to deliver electric capacity from the Large Generating Facility, pursuant to the terms of the NYISO OATT.

**Class Year Deliverability Study** shall mean an assessment, conducted by the NYISO staff in cooperation with Market Participants, to determine the System Deliverability Upgrades required for each generation and merchant transmission project included in the Class Year Interconnection Facilities Study to interconnect to the New York State Transmission System in compliance with the NYISO Deliverability Interconnection Standard.

**Clustering** shall mean the process whereby a group of Interconnection Requests is studied together, instead of serially, for the purpose of conducting the Interconnection System Reliability Impact Study.

**Commercial Operation** shall mean the status of a Large Generating Facility that has commenced generating electricity for sale, excluding electricity generated during Trial Operation.

**Commercial Operation Date** of a unit shall mean the date on which the Large Generating Facility commences Commercial Operation as agreed to by the Parties pursuant to Appendix E to this Agreement.

**Confidential Information** shall mean any information that is defined as confidential by Article 22 of this Agreement.

## SERVICE AGREEMENT NO. 1774

**Connecting Transmission Owner** shall mean the New York public utility or authority (or its designated agent) that (i) owns facilities used for the transmission of Energy in interstate commerce and provides Transmission Service under the Tariff, (ii) owns, leases or otherwise possesses an interest in the portion of the New York State Transmission System at the Point of Interconnection, and (iii) is a Party to the Standard Large Interconnection Agreement.

**Connecting Transmission Owner's Attachment Facilities** shall mean all facilities and equipment owned, controlled or operated by the Connecting Transmission Owner from the Point of Change of Ownership to the Point of Interconnection as identified in Appendix A to the Standard Large Generator Interconnection Agreement, including any modifications, additions or upgrades to such facilities and equipment. Connecting Transmission Owner's Attachment Facilities are sole use facilities and shall not include Stand Alone System Upgrade Facilities or System Upgrade Facilities.

**Control Area** shall mean an electric power system or combination of electric power systems to which a common automatic generation control scheme is applied in order to: (1) match, at all times, the power output of the Generators within the electric power system(s) and capacity and energy purchased from entities outside the electric power system(s), with the Load within the electric power system(s); (2) maintain scheduled interchange with other Control Areas, within the limits of Good Utility Practice; (3) maintain the frequency of the electric power system(s) within reasonable limits in accordance with Good Utility Practice; and (4) provide sufficient generating capacity to maintain Operating Reserves in accordance with Good Utility Practice. A Control Area must be certified by the NPCC.

**Default** shall mean the failure of a Party in Breach of this Agreement to cure such Breach in accordance with Article 17 of this Agreement.

**Deliverability Interconnection Standard** shall mean the standard that must be met by any Large Generating Facility proposing to interconnect to the New York State Transmission System and become a qualified Installed Capacity Supplier. To meet the NYISO Deliverability Interconnection Standard, the Developer of the proposed Large Generating Facility must, in accordance with the rules in Attachment S to the NYISO OATT, fund or commit to fund the System Deliverability Upgrades identified for its project in the Class Year Deliverability Study.

**Developer** shall mean an Eligible Customer developing a Large Generating Facility, proposing to connect to the New York State Transmission System, in compliance with the NYISO Minimum Interconnection Standard.

**Developer's Attachment Facilities** shall mean all facilities and equipment, as identified in Appendix A of this Agreement, that are located between the Large Generating Facility and the Point of Change of Ownership, including any modification, addition, or upgrades to such facilities and equipment necessary to physically and electrically interconnect the Large Generating Facility to the New York State Transmission System. Developer's Attachment Facilities are sole use facilities.

## SERVICE AGREEMENT NO. 1774

**Dispute Resolution** shall mean the procedure described in Article 27 of this Agreement for resolution of a dispute between the Parties.

**Effective Date** shall mean the date on which this Agreement becomes effective upon execution by the Parties, subject to acceptance by the Commission, or if filed unexecuted, upon the date specified by the Commission.

**Emergency State** shall mean the condition or state that the New York State Power System is in when an abnormal condition occurs that requires automatic or immediate manual action to prevent or limit loss of the New York State Transmission System or Generators that could adversely affect the reliability of the New York State Power System.

**Energy Resource Interconnection Service (“ERIS”)** shall mean the service provided by NYISO to interconnect the Developer’s Large Generating Facility to the New York State Transmission System in accordance with the NYISO Minimum Interconnection Standard, to enable the New York State Transmission System to receive Energy and Ancillary Services from the Large Generating Facility, pursuant to the terms of the NYISO OATT.

**Engineering & Procurement (E&P) Agreement** shall mean an agreement that authorizes Connecting Transmission Owner to begin engineering and procurement of long lead-time items necessary for the establishment of the interconnection in order to advance the implementation of the Interconnection Request.

**Environmental Law** shall mean Applicable Laws or Regulations relating to pollution or protection of the environment or natural resources.

**Federal Power Act** shall mean the Federal Power Act, as amended, 16 U.S.C. §§ 791a *et seq.* (“FPA”).

**FERC** shall mean the Federal Energy Regulatory Commission (“Commission”) or its successor.

**Force Majeure** shall mean any act of God, labor disturbance, act of the public enemy, war, insurrection, riot, fire, storm or flood, explosion, breakage or accident to machinery or equipment, any order, regulation or restriction imposed by governmental, military or lawfully established civilian authorities, or any other cause beyond a Party’s control. A Force Majeure event does not include acts of negligence or intentional wrongdoing by the Party claiming Force Majeure.

**Generating Facility** shall mean Developer’s device for the production of electricity identified in the Interconnection Request, but shall not include the Developer’s Attachment Facilities.

## SERVICE AGREEMENT NO. 1774

**Generating Facility Capacity** shall mean the net seasonal capacity of the Generating Facility and the aggregate net seasonal capacity of the Generating Facility where it includes multiple energy production devices.

**Good Utility Practice** shall mean any of the practices, methods and acts engaged in or approved by a significant portion of the electric industry during the relevant time period, or any of the practices, methods and acts which, in the exercise of reasonable judgment in light of the facts known at the time the decision was made, could have been expected to accomplish the desired result at a reasonable cost consistent with good business practices, reliability, safety and expedition. Good Utility Practice is not intended to be limited to the optimum practice, method, or act to the exclusion of all others, but rather to delineate acceptable practices, methods, or acts generally accepted in the region.

**Governmental Authority** shall mean any federal, state, local or other governmental regulatory or administrative agency, court, commission, department, board, or other governmental subdivision, legislature, rulemaking board, tribunal, or other governmental authority having jurisdiction over any of the Parties, their respective facilities, or the respective services they provide, and exercising or entitled to exercise any administrative, executive, police, or taxing authority or power; provided, however, that such term does not include Developer, NYISO, Affected Transmission Owner, Connecting Transmission Owner, or any Affiliate thereof.

**Hazardous Substances** shall mean any chemicals, materials or substances defined as or included in the definition of “hazardous substances,” “hazardous wastes,” “hazardous materials,” “hazardous constituents,” “restricted hazardous materials,” “extremely hazardous substances,” “toxic substances,” “radioactive substances,” “contaminants,” “pollutants,” “toxic pollutants” or words of similar meaning and regulatory effect under any applicable Environmental Law, or any other chemical, material or substance, exposure to which is prohibited, limited or regulated by any applicable Environmental Law.

**Highway** shall mean 115 kV and higher transmission facilities that comprise the following NYCA interfaces: Dysinger East, West Central, Volney East, Moses South, Central East/Total East, UPNY-SENY and UPNY-ConEd, and their immediately connected, in series, Bulk Power System facilities in New York State. Each interface shall be evaluated to determine additional “in series” facilities, defined as any transmission facility higher than 115 kV that (a) is located in an upstream or downstream zone adjacent to the interface and (b) has a power transfer distribution factor (DFAX) equal to or greater than five percent when the aggregate of generation in zones or systems adjacent to the upstream zone or zones which define the interface is shifted to the aggregate of generation in zones or systems adjacent to the downstream zone or zones which define the interface. In determining “in series” facilities for Dysinger East and West Central interfaces, the 115 kV and 230 kV tie lines between NYCA and PJM located in LBMP Zones A and B shall not participate in the transfer. Highway transmission facilities are listed in ISO Procedures.

## SERVICE AGREEMENT NO. 1774

**Initial Synchronization Date** shall mean the date upon which the Large Generating Facility is initially synchronized and upon which Trial Operation begins.

**In-Service Date** shall mean the date upon which the Developer reasonably expects it will be ready to begin use of the Connecting Transmission Owner's Attachment Facilities to obtain back feed power.

**Interconnection Facilities Study** shall mean a study conducted by NYISO or a third party consultant for the Developer to determine a list of facilities (including Connecting Transmission Owner's Attachment Facilities and System Upgrade Facilities and System Deliverability Upgrades as identified in the Interconnection System Reliability Impact Study), the cost of those facilities, and the time required to interconnect the Large Generating Facility with the New York State Transmission System. The scope of the study is defined in Section 30.8 of the Standard Large Facility Interconnection Procedures.

**Interconnection Facilities Study Agreement** shall mean the form of agreement contained in Appendix 4 of the Standard Large Facility Interconnection Procedures for conducting the Interconnection Facilities Study.

**Interconnection Feasibility Study** shall mean a preliminary evaluation of the system impact and cost of interconnecting the Large Generating Facility to the New York State Transmission System, the scope of which is described in Section 30.6 of the Standard Large Facility Interconnection Procedures.

**Interconnection Feasibility Study Agreement** shall mean the form of agreement contained in Appendix 2 of the Standard Large Facility Interconnection Procedures for conducting the Interconnection Feasibility Study.

**Interconnection Request** shall mean a Developer's request, in the form of Appendix 1 to the Standard Large Facility Interconnection Procedures, in accordance with the Tariff, to interconnect a new Large Generating Facility to the New York State Transmission System, or to increase the capacity of, or make a material modification to the operating characteristics of, an existing Large Generating Facility that is interconnected with the New York State Transmission System.

**Interconnection Study** shall mean any of the following studies: the Interconnection Feasibility Study, the Interconnection System Reliability Impact Study, and the Interconnection Facilities Study described in the Standard Large Facility Interconnection Procedures.

**Interconnection System Reliability Impact Study ("SRIS")** shall mean an engineering study, conducted in accordance with Section 30.7 of the Large Facility Interconnection Procedures, that evaluates the impact of the proposed Large Generating Facility on the safety and reliability of the New York State Transmission System and, if applicable, an Affected System, to determine what Attachment Facilities and System Upgrade Facilities are needed for the proposed

## SERVICE AGREEMENT NO. 1774

Large Generation Facility of the Developer to connect reliably to the New York State Transmission System in a manner that meets the NYISO Minimum Interconnection Standard.

**Interconnection System Reliability Impact Study Agreement** shall mean the form of agreement contained in Appendix 3 of the Standard Large Facility Interconnection Procedures for conducting the Interconnection System Reliability Impact Study.

**IRS** shall mean the Internal Revenue Service.

**Large Generating Facility** shall mean a Generating Facility having a Generating Facility Capacity of more than 20 MW.

**Loss** shall mean any and all losses relating to injury to or death of any person or damage to property, demand, suits, recoveries, costs and expenses, court costs, attorney fees, and all other obligations by or to third parties, arising out of or resulting from the Indemnified Party's performance or non-performance of its obligations under this Agreement on behalf of the Indemnifying Party, except in cases of gross negligence or intentional wrongdoing by the Indemnified Party.

**Material Modification** shall mean those modifications that have a material impact on the cost or timing of any Interconnection Request with a later queue priority date.

**Metering Equipment** shall mean all metering equipment installed or to be installed at the Large Generating Facility pursuant to this Agreement at the metering points, including but not limited to instrument transformers, MWh-meters, data acquisition equipment, transducers, remote terminal unit, communications equipment, phone lines, and fiber optics.

**Minimum Interconnection Standard** shall mean the reliability standard that must be met by any Large Generating Facility proposing to connect to the New York State Transmission System. The Standard is designed to ensure reliable access by the proposed project to the New York State Transmission System. The Standard does not impose any deliverability test or deliverability requirement on the proposed interconnection.

**NERC** shall mean the North American Electric Reliability Council or its successor organization.

**New York State Transmission System** shall mean the entire New York State electric transmission system, which includes (i) the Transmission Facilities under ISO Operational Control; (ii) the Transmission Facilities Requiring ISO Notification; and (iii) all remaining transmission facilities within the New York Control Area.

**Notice of Dispute** shall mean a written notice of a dispute or claim that arises out of or in connection with this Agreement or its performance.

## SERVICE AGREEMENT NO. 1774

**NPCC** shall mean the Northeast Power Coordinating Council or its successor organization.

**NYSRC** shall mean the New York State Reliability Council or its successor organization.

**Optional Interconnection Study** shall mean a sensitivity analysis based on assumptions specified by the Developer in the Optional Interconnection Study Agreement.

**Optional Interconnection Study Agreement** shall mean the form of agreement contained in Appendix 5 of the Standard Large Facility Interconnection Procedures for conducting the Optional Interconnection Study.

**Other Interfaces** shall mean interfaces into New York capacity regions, Zone J and Zone K, and external ties into the New York Control Area.

**Party or Parties** shall mean NYISO, Connecting Transmission Owner, or Developer or any combination of the above.

**Point of Change of Ownership** shall mean the point, as set forth in Appendix A to this Agreement, where the Developer's Attachment Facilities connect to the Connecting Transmission Owner's Attachment Facilities.

**Point of Interconnection** shall mean the point, as set forth in Appendix A to this Agreement, where the Attachment Facilities connect to the New York State Transmission System.

**Queue Position** shall mean the order of a valid Interconnection Request, relative to all other pending valid Interconnection Requests, that is established based upon the date and time of receipt of the valid Interconnection Request by NYISO.

**Reasonable Efforts** shall mean, with respect to an action required to be attempted or taken by a Party under this Agreement, efforts that are timely and consistent with Good Utility Practice and are otherwise substantially equivalent to those a Party would use to protect its own interests.

**Scoping Meeting** shall mean the meeting between representatives of the Developer, NYISO and Connecting Transmission Owner conducted for the purpose of discussing alternative interconnection options, to exchange information including any transmission data and earlier study evaluations that would be reasonably expected to impact such interconnection options, to analyze such information, and to determine the potential feasible Points of Interconnection.

## SERVICE AGREEMENT NO. 1774

**Services Tariff** shall mean the NYISO Market Administration and Control Area Tariff, as filed with the Commission, and as amended or supplemented from time to time, or any successor tariff thereto.

**Site Control** shall mean documentation reasonably demonstrating: (1) ownership of, a leasehold interest in, or a right to develop a site for the purpose of constructing the Large Generating Facility; (2) an option to purchase or acquire a leasehold site for such purpose; or (3) an exclusivity or other business relationship between Developer and the entity having the right to sell, lease or grant Developer the right to possess or occupy a site for such purpose.

**Stand Alone System Upgrade Facilities** shall mean System Upgrade Facilities that a Developer may construct without affecting day-to-day operations of the New York State Transmission System during their construction. NYISO, the Connecting Transmission Owner and the Developer must agree as to what constitutes Stand Alone System Upgrade Facilities and identify them in Appendix A to this Agreement.

**Standard Large Facility Interconnection Procedures (“LFIP”)** shall mean the interconnection procedures applicable to an Interconnection Request pertaining to a Large Generating Facility that are included in Attachment X of the NYISO OATT.

**Standard Large Generator Interconnection Agreement (“LGIA”)** shall mean this Agreement, the form of interconnection agreement applicable to an Interconnection Request pertaining to a Large Generating Facility, that is included in Attachment X of the NYISO OATT.

**System Deliverability Upgrades** shall mean the least costly configuration of commercially available components of electrical equipment that can be used, consistent with Good Utility Practice and Applicable Reliability Requirements, to make the modifications or additions to Byways and Highways and Other Interfaces on the existing New York State Transmission System that are required for the proposed project to connect reliably to the system in a manner that meets the NYISO Deliverability Interconnection Standard at the requested level of Capacity Resource Interconnection Service.

**System Protection Facilities** shall mean the equipment, including necessary protection signal communications equipment, required to (1) protect the New York State Transmission System from faults or other electrical disturbances occurring at the Large Generating Facility and (2) protect the Large Generating Facility from faults or other electrical system disturbances occurring on the New York State Transmission System or on other delivery systems or other generating systems to which the New York State Transmission System is directly connected.

**System Upgrade Facilities** shall mean the least costly configuration of commercially available components of electrical equipment that can be used, consistent with Good Utility Practice and Applicable Reliability Requirements, to make the modifications to the existing transmission system that are required to maintain system reliability due to: (i) changes in the system, including such changes as load growth and changes in load pattern, to be addressed in

## SERVICE AGREEMENT NO. 1774

the form of generic generation or transmission projects; and (ii) proposed interconnections. In the case of proposed interconnection projects, System Upgrade Facilities are the modifications or additions to the existing New York State Transmission System that are required for the proposed project to connect reliably to the system in a manner that meets the NYISO Minimum Interconnection Standard.

**Tariff** shall mean the NYISO Open Access Transmission Tariff (“OATT”), as filed with the Commission, and as amended or supplemented from time to time, or any successor tariff.

**Trial Operation** shall mean the period during which Developer is engaged in on-site test operations and commissioning of the Large Generating Facility prior to Commercial Operation.

### ARTICLE 2. EFFECTIVE DATE, TERM AND TERMINATION

- 2.1 Effective Date.** This Agreement shall become effective upon execution by the Parties, subject to acceptance by FERC, or if filed unexecuted, upon the date specified by FERC. The NYISO and Connecting Transmission Owner shall promptly file this Agreement with FERC upon execution in accordance with Article 3.1.
- 2.2 Term of Agreement.** Subject to the provisions of Article 2.3, this Agreement shall remain in effect for a period of twenty (20) years from the Effective Date or such other longer period as the Developer may request and shall be automatically renewed for each successive one-year period thereafter.
- 2.3 Termination.**
- 2.3.1 Written Notice.** This Agreement may be terminated by the Developer after giving the NYISO and Connecting Transmission Owner ninety (90) Calendar Days advance written notice, or by the NYISO and Connecting Transmission Owner notifying FERC after the Large Generating Facility permanently ceases Commercial Operations.
- 2.3.2 Default.** Any Party may terminate this Agreement in accordance with Article 17.
- 2.3.3 Compliance.** Notwithstanding Articles 2.3.1 and 2.3.2, no termination of this Agreement shall become effective until the Parties have complied with all Applicable Laws and Regulations applicable to such termination, including the filing with FERC of a notice of termination of this Agreement, which notice has been accepted for filing by FERC.

## SERVICE AGREEMENT NO. 1774

**2.4 Termination Costs.** If a Party elects to terminate this Agreement pursuant to Article 2.3.1 above, the terminating Party shall pay all costs incurred (including any cancellation costs relating to orders or contracts for Attachment Facilities and equipment) or charges assessed by the other Parties, as of the date of the other Parties' receipt of such notice of termination, that are the responsibility of the terminating Party under this Agreement. In the event of termination by a Party, all Parties shall use commercially Reasonable Efforts to mitigate the costs, damages and charges arising as a consequence of termination. Upon termination of this Agreement, unless otherwise ordered or approved by FERC:

**2.4.1** With respect to any portion of the Connecting Transmission Owner's Attachment Facilities that have not yet been constructed or installed, the Connecting Transmission Owner shall to the extent possible and with Developer's authorization cancel any pending orders of, or return, any materials or equipment for, or contracts for construction of, such facilities; provided that in the event Developer elects not to authorize such cancellation, Developer shall assume all payment obligations with respect to such materials, equipment, and contracts, and the Connecting Transmission Owner shall deliver such material and equipment, and, if necessary, assign such contracts, to Developer as soon as practicable, at Developer's expense. To the extent that Developer has already paid Connecting Transmission Owner for any or all such costs of materials or equipment not taken by Developer, Connecting Transmission Owner shall promptly refund such amounts to Developer, less any costs, including penalties incurred by the Connecting Transmission Owner to cancel any pending orders of or return such materials, equipment, or contracts.

If Developer terminates this Agreement, it shall be responsible for all costs incurred in association with Developer's interconnection, including any cancellation costs relating to orders or contracts for Attachment Facilities and equipment, and other expenses including any System Upgrade Facilities and System Deliverability Upgrades for which the Connecting Transmission Owner has incurred expenses and has not been reimbursed by the Developer.

**2.4.2** Connecting Transmission Owner may, at its option, retain any portion of such materials, equipment, or facilities that Developer chooses not to accept delivery of, in which case Connecting Transmission Owner shall be responsible for all costs associated with procuring such materials, equipment, or facilities.

**2.4.3** With respect to any portion of the Attachment Facilities, and any other facilities already installed or constructed pursuant to the terms of this Agreement, Developer shall be responsible for all costs associated with the

## SERVICE AGREEMENT NO. 1774

removal, relocation or other disposition or retirement of such materials, equipment, or facilities.

- 2.5 Disconnection.** Upon termination of this Agreement, Developer and Connecting Transmission Owner will take all appropriate steps to disconnect the Developer's Large Generating Facility from the New York State Transmission System. All costs required to effectuate such disconnection shall be borne by the terminating Party, unless such termination resulted from the non-terminating Party's Default of this Agreement or such non-terminating Party otherwise is responsible for these costs under this Agreement.
- 2.6 Survival.** This Agreement shall continue in effect after termination to the extent necessary to provide for final billings and payments and for costs incurred hereunder; including billings and payments pursuant to this Agreement; to permit the determination and enforcement of liability and indemnification obligations arising from acts or events that occurred while this Agreement was in effect; and to permit Developer and Connecting Transmission Owner each to have access to the lands of the other pursuant to this Agreement or other applicable agreements, to disconnect, remove or salvage its own facilities and equipment.

### ARTICLE 3. REGULATORY FILINGS

- 3.1 Filing.** NYISO and Connecting Transmission Owner shall file this Agreement (and any amendment hereto) with the appropriate Governmental Authority, if required. Any information related to studies for interconnection asserted by Developer to contain Confidential Information shall be treated in accordance with Article 22 of this Agreement and Attachment F to the NYISO OATT. If the Developer has executed this Agreement, or any amendment thereto, the Developer shall reasonably cooperate with NYISO and Connecting Transmission Owner with respect to such filing and to provide any information reasonably requested by NYISO and Connecting Transmission Owner needed to comply with Applicable Laws and Regulations.

### ARTICLE 4. SCOPE OF INTERCONNECTION SERVICE

- 4.1 Provision of Service.** NYISO will provide Developer with interconnection service of the following type for the term of this Agreement.
- 4.1.1 Product.** NYISO will provide Energy Resource Interconnection Service to Developer at the Point of Interconnection.
- 4.1.2 Developer** is responsible for ensuring that its actual Large Generating Facility output matches the scheduled delivery from the Large Generating Facility to the New York State Transmission System, consistent with the scheduling requirements of the NYISO's FERC-approved market structure,

## SERVICE AGREEMENT NO. 1774

including ramping into and out of such scheduled delivery, as measured at the Point of Interconnection, consistent with the scheduling requirements of the NYISO OATT and any applicable FERC-approved market structure.

- 4.2 No Transmission Delivery Service.** The execution of this Agreement does not constitute a request for, nor agreement to provide, any Transmission Service under the NYISO OATT, and does not convey any right to deliver electricity to any specific customer or Point of Delivery. If Developer wishes to obtain Transmission Service on the New York State Transmission System, then Developer must request such Transmission Service in accordance with the provisions of the NYISO OATT.
- 4.3 No Other Services.** The execution of this Agreement does not constitute a request for, nor agreement to provide Energy, any Ancillary Services or Installed Capacity under the NYISO Market Administration and Control Area Services Tariff (“Services Tariff”). If Developer wishes to supply Energy, Installed Capacity or Ancillary Services, then Developer will make application to do so in accordance with the NYISO Services Tariff.

## ARTICLE 5. INTERCONNECTION FACILITIES ENGINEERING, PROCUREMENT, AND CONSTRUCTION

**5.1 Options.** Unless otherwise mutually agreed to by Developer and Connecting Transmission Owner, Developer shall select the In-Service Date, Initial Synchronization Date, and Commercial Operation Date; and either Standard Option or Alternate Option set forth below for completion of the Connecting Transmission Owner’s Attachment Facilities and System Upgrade Facilities and System Deliverability Upgrades as set forth in Appendix A hereto, and such dates and selected option shall be set forth in Appendix B hereto.

**5.1.1 Standard Option.** The Connecting Transmission Owner shall design, procure, and construct the Connecting Transmission Owner’s Attachment Facilities and System Upgrade Facilities and System Deliverability Upgrades, using Reasonable Efforts to complete the Connecting Transmission Owner’s Attachment Facilities and System Upgrade Facilities and System Deliverability Upgrades by the dates set forth in Appendix B hereto. The Connecting Transmission Owner shall not be required to undertake any action which is inconsistent with its standard safety practices, its material and equipment specifications, its design criteria and construction procedures, its labor agreements, and Applicable Laws and Regulations. In the event the Connecting Transmission Owner reasonably expects that it will not be able to complete the Connecting Transmission Owner’s Attachment Facilities and System Upgrade Facilities and System Deliverability Upgrades by the specified dates, the Connecting Transmission Owner shall promptly provide written notice to the Developer

and NYISO, and shall undertake Reasonable Efforts to meet the earliest dates thereafter.

**5.1.2 Alternate Option.** If the dates designated by Developer are acceptable to Connecting Transmission Owner, the Connecting Transmission Owner shall so notify Developer and NYISO within thirty (30) Calendar Days, and shall assume responsibility for the design, procurement and construction of the Connecting Transmission Owner's Attachment Facilities by the designated dates.

If Connecting Transmission Owner subsequently fails to complete Connecting Transmission Owner's Attachment Facilities by the In-Service Date, to the extent necessary to provide back feed power; or fails to complete System Upgrade Facilities or System Deliverability Upgrades by the Initial Synchronization Date to the extent necessary to allow for Trial Operation at full power output, unless other arrangements are made by the Developer and Connecting Transmission Owner for such Trial Operation; or fails to complete the System Upgrade Facilities and System Deliverability Upgrades by the Commercial Operation Date, as such dates are reflected in Appendix B hereto; Connecting Transmission Owner shall pay Developer liquidated damages in accordance with Article 5.3, Liquidated Damages, provided, however, the dates designated by Developer shall be extended day for day for each day that NYISO refuses to grant clearances to install equipment.

**5.1.3 Option to Build.** If the dates designated by Developer are not acceptable to Connecting Transmission Owner, the Connecting Transmission Owner shall so notify the Developer and NYISO within thirty (30) Calendar Days, and unless the Developer and Connecting Transmission Owner agree otherwise, Developer shall have the option to assume responsibility for the design, procurement and construction of Connecting Transmission Owner's Attachment Facilities and Stand Alone System Upgrade Facilities on the dates specified in Article 5.1.2; provided that if an Attachment Facility or Stand Alone System Upgrade Facility is needed for more than one Developer's project, Developer's option to build such Facility shall be contingent on the agreement of all other affected Developers. NYISO, Connecting Transmission Owner and Developer must agree as to what constitutes Stand Alone System Upgrade Facilities and identify such Stand Alone System Upgrade Facilities in Appendix A hereto. Except for Stand Alone System Upgrade Facilities, Developer shall have no right to construct System Upgrade Facilities under this option.

## SERVICE AGREEMENT NO. 1774

**5.1.4 Negotiated Option.** If the Developer elects not to exercise its option under Article 5.1.3, Option to Build, Developer shall so notify Connecting Transmission Owner and NYISO within thirty (30) Calendar Days, and the Developer and Connecting Transmission Owner shall in good faith attempt to negotiate terms and conditions (including revision of the specified dates and liquidated damages, the provision of incentives or the procurement and construction of a portion of the Connecting Transmission Owner's Attachment Facilities and Stand Alone System Upgrade Facilities by Developer) pursuant to which Connecting Transmission Owner is responsible for the design, procurement and construction of the Connecting Transmission Owner's Attachment Facilities and System Upgrade Facilities and System Deliverability Upgrades. If the two Parties are unable to reach agreement on such terms and conditions, Connecting Transmission Owner shall assume responsibility for the design, procurement and construction of the Connecting Transmission Owner's Attachment Facilities and System Upgrade Facilities and System Deliverability Upgrades pursuant to 5.1.1, Standard Option.

**5.2 General Conditions Applicable to Option to Build.** If Developer assumes responsibility for the design, procurement and construction of the Connecting Transmission Owner's Attachment Facilities and Stand Alone System Upgrade Facilities,

(1) Developer shall engineer, procure equipment, and construct the Connecting Transmission Owner's Attachment Facilities and Stand Alone System Upgrade Facilities (or portions thereof) using Good Utility Practice and using standards and specifications provided in advance by the Connecting Transmission Owner;

(2) Developer's engineering, procurement and construction of the Connecting Transmission Owner's Attachment Facilities and Stand Alone System Upgrade Facilities shall comply with all requirements of law to which Connecting Transmission Owner would be subject in the engineering, procurement or construction of the Connecting Transmission Owner's Attachment Facilities and Stand Alone System Upgrade Facilities;

(3) Developer agrees to comply with all applicable provisions of Section 220 of the New York Labor Law ("Section 220"), as it may be amended from time to time. Pursuant to the requirements of Section 220, Developer agrees that, for work performed on existing Connecting Transmission Owner facilities (i.e., "public work"):

(a) Each laborer, workman or mechanic shall be paid no less than the prevailing wages as defined in Section 220,

**SERVICE AGREEMENT NO. 1774**

(b) The filing of payrolls shall be made in a manner consistent with subdivision three-a (3(a)) of Section 220; this is a condition precedent to payment of any sums due and owing to any person for work done upon the project, and

(c) No laborer, workman or mechanic shall be permitted or required to work more than eight hours in any one calendar day or more than five days in any one week except in cases of extraordinary emergency including fire, flood, or danger to life or property.<sup>1</sup>

(4) Connecting Transmission Owner shall review and approve the engineering design, equipment acceptance tests, and the construction of the Connecting Transmission Owner's Attachment Facilities and Stand Alone System Upgrade Facilities;

(5) Prior to commencement of construction, Developer shall provide to Connecting Transmission Owner and NYISO a schedule for construction of the Connecting Transmission Owner's Attachment Facilities and Stand Alone System Upgrade Facilities, and shall promptly respond to requests for information from Connecting Transmission Owner or NYISO;

(6) At any time during construction, Connecting Transmission Owner shall have the right to gain unrestricted access to the Connecting Transmission Owner's Attachment Facilities and Stand Alone System Upgrade Facilities and to conduct inspections of the same;

(7) At any time during construction, should any phase of the engineering, equipment procurement, or construction of the Connecting Transmission Owner's Attachment Facilities and Stand Alone System Upgrade Facilities not meet the standards and specifications provided by Connecting Transmission Owner, the Developer shall be obligated to remedy deficiencies in that portion of the Connecting Transmission Owner's Attachment Facilities and Stand Alone System Upgrade Facilities;

(8) Developer shall indemnify Connecting Transmission Owner and NYISO for claims arising from the Developer's construction of Connecting Transmission Owner's Attachment Facilities and Stand Alone System Upgrade Facilities under procedures applicable to Article 18.1 Indemnity;

(9) Developer shall transfer control of Connecting Transmission Owner's Attachment Facilities and Stand Alone System Upgrade Facilities to the Connecting Transmission Owner;

---

<sup>1</sup> Developer reserves its rights set forth in Section 220 to obtain dispensation permitting laborers, workers and mechanics to work additional hours or days per week.

## SERVICE AGREEMENT NO. 1774

(10) Unless the Developer and Connecting Transmission Owner otherwise agree, Developer shall transfer ownership of Connecting Transmission Owner's Attachment Facilities and Stand Alone System Upgrade Facilities to Connecting Transmission Owner;

(11) Connecting Transmission Owner shall approve and accept for operation and maintenance the Connecting Transmission Owner's Attachment Facilities and Stand Alone System Upgrade Facilities to the extent engineered, procured, and constructed in accordance with this Article 5.2; and

(12) Developer shall deliver to NYISO and Connecting Transmission Owner "as built" drawings, information, and any other documents that are reasonably required by NYISO or Connecting Transmission Owner to assure that the Attachment Facilities and Stand Alone System Upgrade Facilities are built to the standards and specifications required by Connecting Transmission Owner.

**5.3 Liquidated Damages.** The actual damages to the Developer, in the event the Connecting Transmission Owner's Attachment Facilities or System Upgrade Facilities or System Deliverability Upgrades are not completed by the dates designated by the Developer and accepted by the Connecting Transmission Owner pursuant to subparagraphs 5.1.2 or 5.1.4, above, may include Developer's fixed operation and maintenance costs and lost opportunity costs. Such actual damages are uncertain and impossible to determine at this time. Because of such uncertainty, any liquidated damages paid by the Connecting Transmission Owner to the Developer in the event that Connecting Transmission Owner does not complete any portion of the Connecting Transmission Owner's Attachment Facilities or System Upgrade Facilities or System Deliverability Upgrades by the applicable dates, shall be an amount equal to 1/2 of 1 percent per day of the actual cost of the Connecting Transmission Owner's Attachment Facilities and System Upgrade Facilities and System Deliverability Upgrades, in the aggregate, for which Connecting Transmission Owner has assumed responsibility to design, procure and construct.

However, in no event shall the total liquidated damages exceed 20 percent of the actual cost of the Connecting Transmission Owner Attachment Facilities and System Upgrade Facilities and System Deliverability Upgrades for which the Connecting Transmission Owner has assumed responsibility to design, procure, and construct. The foregoing payments will be made by the Connecting Transmission Owner to the Developer as just compensation for the damages caused to the Developer, which actual damages are uncertain and impossible to determine at this time, and as reasonable liquidated damages, but not as a penalty or a method to secure performance of this Agreement. Liquidated damages, when the Developer and Connecting Transmission Owner agree to them, are the exclusive remedy for the Connecting Transmission Owner's failure to meet its schedule.

Further, Connecting Transmission Owner shall not pay liquidated damages to Developer if: (1) Developer is not ready to commence use of the Connecting Transmission Owner's

## SERVICE AGREEMENT NO. 1774

Attachment Facilities or System Upgrade Facilities or System Deliverability Upgrades to take the delivery of power for the Developer's Large Generating Facility's Trial Operation or to export power from the Developer's Large Generating Facility on the specified dates, unless the Developer would have been able to commence use of the Connecting Transmission Owner's Attachment Facilities or System Upgrade Facilities or System Deliverability Upgrades to take the delivery of power for Developer's Large Generating Facility's Trial Operation or to export power from the Developer's Large Generating Facility, but for Connecting Transmission Owner's delay; (2) the Connecting Transmission Owner's failure to meet the specified dates is the result of the action or inaction of the Developer or any other Developer who has entered into a Standard Large Generator Interconnection Agreement with the Connecting Transmission Owner and NYISO, or action or inaction by any other Party, or any other cause beyond Connecting Transmission Owner's reasonable control or reasonable ability to cure; (3) the Developer has assumed responsibility for the design, procurement and construction of the Connecting Transmission Owner's Attachment Facilities and Stand Alone System Upgrade Facilities; or (4) the Connecting Transmission Owner and Developer have otherwise agreed.

In no event shall NYISO have any liability whatever to Developer for liquidated damages associated with the engineering, procurement or construction of Attachment Facilities or System Upgrade Facilities or System Deliverability Upgrades.

**5.4 Power System Stabilizers.** The Developer shall procure, install, maintain and operate Power System Stabilizers in accordance with the requirements identified in the Interconnection Studies conducted for Developer's Large Generating Facility. NYISO and Connecting Transmission Owner reserve the right to reasonably establish minimum acceptable settings for any installed Power System Stabilizers, subject to the design and operating limitations of the Large Generating Facility. If the Large Generating Facility's Power System Stabilizers are removed from service or not capable of automatic operation, the Developer shall immediately notify the Connecting Transmission Owner and NYISO. The requirements of this paragraph shall not apply to wind generators.

**5.5 Equipment Procurement.** If responsibility for construction of the Connecting Transmission Owner's Attachment Facilities or System Upgrade Facilities or System Deliverability Upgrades is to be borne by the Connecting Transmission Owner, then the Connecting Transmission Owner shall commence design of the Connecting Transmission Owner's Attachment Facilities or System Upgrade Facilities or System Deliverability Upgrades and procure necessary equipment as soon as practicable after all of the following conditions are satisfied, unless the Developer and Connecting Transmission Owner otherwise agree in writing:

**5.5.1** NYISO and Connecting Transmission Owner have completed the Interconnection Facilities Study pursuant to the Interconnection Facilities Study Agreement;

## SERVICE AGREEMENT NO. 1774

**5.5.2** The NYISO has completed the required cost allocation analyses, and Developer has accepted his share of the costs for necessary System Upgrade Facilities and System Deliverability Upgrades in accordance with the provisions of Attachment S of the NYISO OATT;

**5.5.3** The Connecting Transmission Owner has received written authorization to proceed with design and procurement from the Developer by the date specified in Appendix B hereto; and

**5.5.4** The Developer has provided security to the Connecting Transmission Owner in accordance with Article 11.5 by the dates specified in Appendix B hereto.

**5.6 Construction Commencement.** The Connecting Transmission Owner shall commence construction of the Connecting Transmission Owner's Attachment Facilities and System Upgrade Facilities and System Deliverability Upgrades for which it is responsible as soon as practicable after the following additional conditions are satisfied:

**5.6.1** Approval of the appropriate Governmental Authority has been obtained for any facilities requiring regulatory approval;

**5.6.2** Necessary real property rights and rights-of-way have been obtained, to the extent required for the construction of a discrete aspect of the Connecting Transmission Owner's Attachment Facilities and System Upgrade Facilities and System Deliverability Upgrades;

**5.6.3** The Connecting Transmission Owner has received written authorization to proceed with construction from the Developer by the date specified in Appendix B hereto; and

**5.6.4** The Developer has provided security to the Connecting Transmission Owner in accordance with Article 11.5 by the dates specified in Appendix B hereto.

**5.7 Work Progress.** The Developer and Connecting Transmission Owner will keep each other, and NYISO, advised periodically as to the progress of their respective design, procurement and construction efforts. Any Party may, at any time, request a progress report from the Developer or Connecting Transmission Owner. If, at any time, the Developer determines that the completion of the Connecting Transmission Owner's Attachment Facilities will not be required until after the specified In-Service Date, the Developer will provide written notice to the Connecting Transmission Owner and

## SERVICE AGREEMENT NO. 1774

NYISO of such later date upon which the completion of the Connecting Transmission Owner's Attachment Facilities will be required.

**5.8 Information Exchange.** As soon as reasonably practicable after the Effective Date, the Developer and Connecting Transmission Owner shall exchange information, and provide NYISO the same information, regarding the design and compatibility of their respective Attachment Facilities and compatibility of the Attachment Facilities with the New York State Transmission System, and shall work diligently and in good faith to make any necessary design changes.

**5.9 Limited Operation.** If any of the Connecting Transmission Owner's Attachment Facilities or System Upgrade Facilities or System Deliverability Upgrades are not reasonably expected to be completed prior to the Commercial Operation Date of the Developer's Large Generating Facility, NYISO shall, upon the request and at the expense of Developer, in conjunction with the Connecting Transmission Owner, perform operating studies on a timely basis to determine the extent to which the Developer's Large Generating Facility and the Developer's Attachment Facilities may operate prior to the completion of the Connecting Transmission Owner's Attachment Facilities or System Upgrade Facilities or System Deliverability Upgrades consistent with Applicable Laws and Regulations, Applicable Reliability Standards, Good Utility Practice, and this Agreement. Connecting Transmission Owner and NYISO shall permit Developer to operate the Developer's Large Generating Facility and the Developer's Attachment Facilities in accordance with the results of such studies.

**5.10 Developer's Attachment Facilities ("DAF").** Developer shall, at its expense, design, procure, construct, own and install the DAF, as set forth in Appendix A hereto.

**5.10.1 DAF Specifications.** Developer shall submit initial specifications for the DAF, including System Protection Facilities, to Connecting Transmission Owner and NYISO at least one hundred eighty (180) Calendar Days prior to the Initial Synchronization Date; and final specifications for review and comment at least ninety (90) Calendar Days prior to the Initial Synchronization Date. Connecting Transmission Owner and NYISO shall review such specifications to ensure that the DAF are compatible with the technical specifications, operational control, and safety requirements of the Connecting Transmission Owner and NYISO and comment on such specifications within thirty (30) Calendar Days of Developer's submission. All specifications provided hereunder shall be deemed to be Confidential Information.

**5.10.2 No Warranty.** The review of Developer's final specifications by Connecting Transmission Owner and NYISO shall not be construed as confirming, endorsing, or providing a warranty as to the design, fitness, safety, durability or reliability of the Large Generating Facility, or the DAF.

## SERVICE AGREEMENT NO. 1774

Developer shall make such changes to the DAF as may reasonably be required by Connecting Transmission Owner or NYISO, in accordance with Good Utility Practice, to ensure that the DAF are compatible with the technical specifications, operational control, and safety requirements of the Connecting Transmission Owner and NYISO.

**5.10.3 DAF Construction.** The DAF shall be designed and constructed in accordance with Good Utility Practice. Within one hundred twenty (120) Calendar Days after the Commercial Operation Date, unless the Developer and Connecting Transmission Owner agree on another mutually acceptable deadline, the Developer shall deliver to the Connecting Transmission Owner and NYISO “as-built” drawings, information and documents for the DAF, such as: a one-line diagram, a site plan showing the Large Generating Facility and the DAF, plan and elevation drawings showing the layout of the DAF, a relay functional diagram, relaying AC and DC schematic wiring diagrams and relay settings for all facilities associated with the Developer’s step-up transformers, the facilities connecting the Large Generating Facility to the step-up transformers and the DAF, and the impedances (determined by factory tests) for the associated step-up transformers and the Large Generating Facility. The Developer shall provide to, and coordinate with, Connecting Transmission Owner and NYISO with respect to proposed specifications for the excitation system, automatic voltage regulator, Large Generating Facility control and protection settings, transformer tap settings, and communications, if applicable.

**5.11 Connecting Transmission Owner’s Attachment Facilities Construction.** The Connecting Transmission Owner’s Attachment Facilities shall be designed and constructed in accordance with Good Utility Practice. Upon request, within one hundred twenty (120) Calendar Days after the Commercial Operation Date, unless the Connecting Transmission Owner and Developer agree on another mutually acceptable deadline, the Connecting Transmission Owner shall deliver to the Developer the following “as-built” drawings, information and documents for the Connecting Transmission Owner’s Attachment Facilities: those “as-built” drawings, information and documents reasonably required by the Developer and related to the Connecting Transmission Owner’s Attachment Facilities constructed by the Connecting Transmission Owner, if any.

The Connecting Transmission Owner shall transfer operational control of the Connecting Transmission Owner’s Attachment Facilities and Stand Alone System Upgrade Facilities to the NYISO upon completion of such facilities.

**5.12 Access Rights.** Upon reasonable notice and supervision by the Granting Party, and subject to any required or necessary regulatory approvals, either the Connecting Transmission Owner or Developer (“Granting Party”) shall furnish to the other of those

## SERVICE AGREEMENT NO. 1774

two Parties (“Access Party”) at no cost any rights of use, licenses, rights of way and easements with respect to lands owned or controlled by the Granting Party, its agents (if allowed under the applicable agency agreement), or any Affiliate, that are necessary to enable the Access Party to obtain ingress and egress at the Point of Interconnection to construct, operate, maintain, repair, test (or witness testing), inspect, replace or remove facilities and equipment to: (i) interconnect the Large Generating Facility with the New York State Transmission System; (ii) operate and maintain the Large Generating Facility, the Attachment Facilities and the New York State Transmission System; and (iii) disconnect or remove the Access Party’s facilities and equipment upon termination of this Agreement. In exercising such licenses, rights of way and easements, the Access Party shall not unreasonably disrupt or interfere with normal operation of the Granting Party’s business and shall adhere to the safety rules and procedures established in advance, as may be changed from time to time, by the Granting Party and provided to the Access Party. The Access Party shall indemnify the Granting Party against all claims of injury or damage from third parties resulting from the exercise of the access rights provided for herein.

**5.13 Lands of Other Property Owners.** If any part of the Connecting Transmission Owner’s Attachment Facilities and/or System Upgrade Facilities and/or System Deliverability Upgrades is to be installed on property owned by persons other than Developer or Connecting Transmission Owner, the Connecting Transmission Owner agrees, to the extent consistent with applicable law, at Developer’s expense to use efforts, similar in nature and extent to those that it typically undertakes for its own or affiliated generation, including use of its eminent domain authority, and to the extent consistent with state law, to procure from such persons any rights of use, licenses, rights of way and easements that are necessary to construct, operate, maintain, test, inspect, replace or remove the Connecting Transmission Owner’s Attachment Facilities and/or System Upgrade Facilities and/or System Deliverability Upgrades upon such property. Notwithstanding the previous sentence, the Connecting Transmission Owner’s exercise of powers and rights to acquire real property or any rights in real property, pursuant to this Section 5.13, is subject to the provisions of the Power Authority Act (or any amendments thereto).

**5.14 Permits.** NYISO, Connecting Transmission Owner and the Developer shall cooperate with each other in good faith in obtaining all permits, licenses and authorizations that are necessary to accomplish the interconnection in compliance with Applicable Laws and Regulations. With respect to this paragraph, Connecting Transmission Owner shall provide permitting assistance to the Developer comparable to that provided to the Connecting Transmission Owner’s own, or an Affiliate’s generation, if any.

**5.15 Early Construction of Base Case Facilities.** Developer may request Connecting Transmission Owner to construct, and Connecting Transmission Owner shall construct, subject to a binding cost allocation agreement reached in accordance with Attachment S to the NYISO OATT, including Section 25.8.7 thereof, using Reasonable Efforts to accommodate Developer’s In-Service Date, all or any portion of any System Upgrade Facilities or System Deliverability Upgrades required for Developer to be interconnected to the New York State Transmission System which are included in the Base Case of the

## SERVICE AGREEMENT NO. 1774

Facilities Study for the Developer, and which also are required to be constructed for another Developer, but where such construction is not scheduled to be completed in time to achieve Developer's In-Service Date.

**5.16 Suspension.** Developer reserves the right, upon written notice to Connecting Transmission Owner and NYISO, to suspend at any time all work by Connecting Transmission Owner associated with the construction and installation of Connecting Transmission Owner's Attachment Facilities and/or System Upgrade Facilities and/or System Deliverability Upgrades required for only that Developer under this Agreement with the condition that the New York State Transmission System shall be left in a safe and reliable condition in accordance with Good Utility Practice and the safety and reliability criteria of Connecting Transmission Owner and NYISO. In such event, Developer shall be responsible for all reasonable and necessary costs and/or obligations in accordance with Attachment S to the NYISO OATT including those which Connecting Transmission Owner (i) has incurred pursuant to this Agreement prior to the suspension and (ii) incurs in suspending such work, including any costs incurred to perform such work as may be necessary to ensure the safety of persons and property and the integrity of the New York State Transmission System during such suspension and, if applicable, any costs incurred in connection with the cancellation or suspension of material, equipment and labor contracts which Connecting Transmission Owner cannot reasonably avoid; provided, however, that prior to canceling or suspending any such material, equipment or labor contract, Connecting Transmission Owner shall obtain Developer's authorization to do so.

Connecting Transmission Owner shall invoice Developer for such costs pursuant to Article 12 and shall use due diligence to minimize its costs. In the event Developer suspends work by Connecting Transmission Owner required under this Agreement pursuant to this Article 5.16, and has not requested Connecting Transmission Owner to recommence the work required under this Agreement on or before the expiration of three (3) years following commencement of such suspension, this Agreement shall be deemed terminated. The three-year period shall begin on the date the suspension is requested, or the date of the written notice to Connecting Transmission Owner and NYISO, if no effective date is specified.

### **5.17 Taxes.**

**5.17.1 Developer Payments Not Taxable.** The Developer and Connecting Transmission Owner intend that all payments or property transfers made by Developer to Connecting Transmission Owner for the installation of the Connecting Transmission Owner's Attachment Facilities and the System Upgrade Facilities and the System Deliverability Upgrades shall be non-taxable, either as contributions to capital, or as an advance, in accordance with the Internal Revenue Code and any applicable state income tax laws

and shall not be taxable as contributions in aid of construction or otherwise under the Internal Revenue Code and any applicable state income tax laws.

**5.17.2 Representations and Covenants.** In accordance with IRS Notice 2001-82 and IRS Notice 88-129, Developer represents and covenants that (i) ownership of the electricity generated at the Large Generating Facility will pass to another party prior to the transmission of the electricity on the New York State Transmission System, (ii) for income tax purposes, the amount of any payments and the cost of any property transferred to the Connecting Transmission Owner for the Connecting Transmission Owner's Attachment Facilities will be capitalized by Developer as an intangible asset and recovered using the straight-line method over a useful life of twenty (20) years, and (iii) any portion of the Connecting Transmission Owner's Attachment Facilities that is a "dual-use intertie," within the meaning of IRS Notice 88-129, is reasonably expected to carry only a de minimis amount of electricity in the direction of the Large Generating Facility. For this purpose, "de minimis amount" means no more than 5 percent of the total power flows in both directions, calculated in accordance with the "5 percent test" set forth in IRS Notice 88-129. This is not intended to be an exclusive list of the relevant conditions that must be met to conform to IRS requirements for non-taxable treatment.

At Connecting Transmission Owner's request, Developer shall provide Connecting Transmission Owner with a report from an independent engineer confirming its representation in clause (iii), above. Connecting Transmission Owner represents and covenants that the cost of the Connecting Transmission Owner's Attachment Facilities paid for by Developer will have no net effect on the base upon which rates are determined.

**5.17.3 Indemnification for the Cost Consequences of Current Tax Liability Imposed Upon the Connecting Transmission Owner.** Notwithstanding Article 5.17.1, Developer shall protect, indemnify and hold harmless Connecting Transmission Owner from the cost consequences of any current tax liability imposed against Connecting Transmission Owner as the result of payments or property transfers made by Developer to Connecting Transmission Owner under this Agreement, as well as any interest and penalties, other than interest and penalties attributable to any delay caused by Connecting Transmission Owner.

Connecting Transmission Owner shall not include a gross-up for the cost consequences of any current tax liability in the amounts it charges Developer under this Agreement unless (i) Connecting Transmission Owner has determined, in good faith, that the payments or property transfers made by Developer to

## SERVICE AGREEMENT NO. 1774

Connecting Transmission Owner should be reported as income subject to taxation or (ii) any Governmental Authority directs Connecting Transmission Owner to report payments or property as income subject to taxation; provided, however, that Connecting Transmission Owner may require Developer to provide security, in a form reasonably acceptable to Connecting Transmission Owner (such as a parental guarantee or a letter of credit), in an amount equal to the cost consequences of any current tax liability under this Article 5.17. Developer shall reimburse Connecting Transmission Owner for such costs on a fully grossed-up basis, in accordance with Article 5.17.4, within thirty (30) Calendar Days of receiving written notification from Connecting Transmission Owner of the amount due, including detail about how the amount was calculated.

This indemnification obligation shall terminate at the earlier of (1) the expiration of the ten-year testing period and the applicable statute of limitation, as it may be extended by the Connecting Transmission Owner upon request of the IRS, to keep these years open for audit or adjustment, or (2) the occurrence of a subsequent taxable event and the payment of any related indemnification obligations as contemplated by this Article 5.17.

**5.17.4 Tax Gross-Up Amount.** Developer's liability for the cost consequences of any current tax liability under this Article 5.17 shall be calculated on a fully grossed-up basis. Except as may otherwise be agreed to by the parties, this means that Developer will pay Connecting Transmission Owner, in addition to the amount paid for the Attachment Facilities and System Upgrade Facilities and System Deliverability Upgrades, an amount equal to (1) the current taxes imposed on Connecting Transmission Owner ("Current Taxes") on the excess of (a) the gross income realized by Connecting Transmission Owner as a result of payments or property transfers made by Developer to Connecting Transmission Owner under this Agreement (without regard to any payments under this Article 5.17) (the "Gross Income Amount") over (b) the present value of future tax deductions for depreciation that will be available as a result of such payments or property transfers (the "Present Value Depreciation Amount"), plus (2) an additional amount sufficient to permit the Connecting Transmission Owner to receive and retain, after the payment of all Current Taxes, an amount equal to the net amount described in clause (1).

For this purpose, (i) Current Taxes shall be computed based on Connecting Transmission Owner's composite federal and state tax rates at the time the payments or property transfers are received and Connecting Transmission Owner will be treated as being subject to tax at the highest marginal rates in effect at that time (the "Current Tax Rate"), and (ii) the Present Value Depreciation Amount shall be computed by discounting Connecting Transmission Owner's anticipated tax depreciation deductions as a result of such payments or property transfers by

## SERVICE AGREEMENT NO. 1774

Connecting Transmission Owner's current weighted average cost of capital. Thus, the formula for calculating Developer's liability to Connecting Transmission Owner pursuant to this Article 5.17.4 can be expressed as follows:  $(\text{Current Tax Rate} \times (\text{Gross Income Amount} - \text{Present Value of Tax Depreciation})) / (1 - \text{Current Tax Rate})$ .

Developer's estimated tax liability in the event taxes are imposed shall be stated in Appendix A, Attachment Facilities and System Upgrade Facilities and System Deliverability Upgrades.

### **5.17.5 Private Letter Ruling or Change or Clarification of Law.** At

Developer's request and expense, Connecting Transmission Owner shall file with the IRS a request for a private letter ruling as to whether any property transferred or sums paid, or to be paid, by Developer to Connecting Transmission Owner under this Agreement are subject to federal income taxation. Developer will prepare the initial draft of the request for a private letter ruling, and will certify under penalties of perjury that all facts represented in such request are true and accurate to the best of Developer's knowledge. Connecting Transmission Owner and Developer shall cooperate in good faith with respect to the submission of such request.

Connecting Transmission Owner shall keep Developer fully informed of the status of such request for a private letter ruling and shall execute either a privacy act waiver or a limited power of attorney, in a form acceptable to the IRS, that authorizes Developer to participate in all discussions with the IRS regarding such request for a private letter ruling. Connecting Transmission Owner shall allow Developer to attend all meetings with IRS officials about the request and shall permit Developer to prepare the initial drafts of any follow-up letters in connection with the request.

**5.17.6 Subsequent Taxable Events.** If, within 10 years from the date on which the relevant Connecting Transmission Owner Attachment Facilities are placed in service, (i) Developer Breaches the covenants contained in Article 5.17.2, (ii) a "disqualification event" occurs within the meaning of IRS Notice 88-129, or (iii) this Agreement terminates and Connecting Transmission Owner retains ownership of the Attachment Facilities and System Upgrade Facilities and System Deliverability Upgrades, the Developer shall pay a tax gross-up for the cost consequences of any current tax liability imposed on Connecting Transmission Owner, calculated using the methodology described in Article 5.17.4 and in accordance with IRS Notice 90-60.

**5.17.7 Contests.** In the event any Governmental Authority determines that Connecting Transmission Owner's receipt of payments or property constitutes income that is subject to taxation, Connecting Transmission Owner shall notify Developer, in writing, within thirty (30) Calendar Days of receiving notification of such determination by a Governmental Authority. Upon the timely written request by Developer and at Developer's sole expense, Connecting Transmission Owner may appeal, protest, seek abatement of, or otherwise oppose such determination. Upon Developer's written request and sole expense, Connecting Transmission Owner may file a claim for refund with respect to any taxes paid under this Article 5.17, whether or not it has received such a determination. Connecting Transmission Owner reserves the right to make all decisions with regard to the prosecution of such appeal, protest, abatement or other contest, including the selection of counsel and compromise or settlement of the claim, but Connecting Transmission Owner shall keep Developer informed, shall consider in good faith suggestions from Developer about the conduct of the contest, and shall reasonably permit Developer or an Developer representative to attend contest proceedings.

Developer shall pay to Connecting Transmission Owner on a periodic basis, as invoiced by Connecting Transmission Owner, Connecting Transmission Owner's documented reasonable costs of prosecuting such appeal, protest, abatement or other contest. At any time during the contest, Connecting Transmission Owner may agree to a settlement either with Developer's consent or after obtaining written advice from nationally-recognized tax counsel, selected by Connecting Transmission Owner, but reasonably acceptable to Developer, that the proposed settlement represents a reasonable settlement given the hazards of litigation. Developer's obligation shall be based on the amount of the settlement agreed to by Developer, or if a higher amount, so much of the settlement that is supported by the written advice from nationally-recognized tax counsel selected under the terms of the preceding sentence. The settlement amount shall be calculated on a fully grossed-up basis to cover any related cost consequences of the current tax liability. Any settlement without Developer's consent or such written advice will relieve Developer from any obligation to indemnify Connecting Transmission Owner for the tax at issue in the contest.

**5.17.8 Refund.** In the event that (a) a private letter ruling is issued to Connecting Transmission Owner which holds that any amount paid or the value of any property transferred by Developer to Connecting Transmission Owner under the terms of this Agreement is not subject to federal income taxation, (b) any legislative change or administrative announcement, notice, ruling or other determination makes it reasonably clear to Connecting Transmission Owner in good faith that any amount paid or the value of any property transferred by Developer to Connecting Transmission Owner under the

## SERVICE AGREEMENT NO. 1774

terms of this Agreement is not taxable to Connecting Transmission Owner, (c) any abatement, appeal, protest, or other contest results in a determination that any payments or transfers made by Developer to Connecting Transmission Owner are not subject to federal income tax, or (d) if Connecting Transmission Owner receives a refund from any taxing authority for any overpayment of tax attributable to any payment or property transfer made by Developer to Connecting Transmission Owner pursuant to this Agreement, Connecting Transmission Owner shall promptly refund to Developer the following:

- (i) Any payment made by Developer under this Article 5.17 for taxes that is attributable to the amount determined to be non-taxable, together with interest thereon,
- (ii) Interest on any amounts paid by Developer to Connecting Transmission Owner for such taxes which Connecting Transmission Owner did not submit to the taxing authority, calculated in accordance with the methodology set forth in FERC's regulations at 18 C.F.R. §35.19a(a)(2)(iii) from the date payment was made by Developer to the date Connecting Transmission Owner refunds such payment to Developer, and
- (iii) With respect to any such taxes paid by Connecting Transmission Owner, any refund or credit Connecting Transmission Owner receives or to which it may be entitled from any Governmental Authority, interest (or that portion thereof attributable to the payment described in clause (i), above) owed to the Connecting Transmission Owner for such overpayment of taxes (including any reduction in interest otherwise payable by Connecting Transmission Owner to any Governmental Authority resulting from an offset or credit); provided, however, that Connecting Transmission Owner will remit such amount promptly to Developer only after and to the extent that Connecting Transmission Owner has received a tax refund, credit or offset from any Governmental Authority for any applicable overpayment of income tax related to the Connecting Transmission Owner's Attachment Facilities.

The intent of this provision is to leave both the Developer and Connecting Transmission Owner, to the extent practicable, in the event that no taxes are due with respect to any payment for Attachment Facilities and System Upgrade Facilities and System Deliverability Upgrades hereunder, in the same position they would have been in had no such tax payments been made.

**5.17.9 Taxes Other Than Income Taxes.** Upon the timely request by Developer, and at Developer's sole expense, Connecting Transmission Owner shall appeal, protest, seek abatement of, or otherwise contest any tax (other than federal or state income tax) asserted or assessed against Connecting Transmission Owner for which Developer may be required to reimburse Connecting Transmission Owner under the terms of this Agreement. Developer shall pay to Connecting Transmission Owner on a periodic basis, as invoiced by Connecting Transmission Owner, Connecting Transmission Owner's documented reasonable costs of prosecuting such appeal, protest, abatement, or other contest. Developer and Connecting Transmission Owner shall cooperate in good faith with respect to any such contest. Unless the payment of such taxes is a prerequisite to an appeal or abatement or cannot be deferred, no amount shall be payable by Developer to Connecting Transmission Owner for such taxes until they are assessed by a final, non-appealable order by any court or agency of competent jurisdiction. In the event that a tax payment is withheld and ultimately due and payable after appeal, Developer will be responsible for all taxes, interest and penalties, other than penalties attributable to any delay caused by Connecting Transmission Owner.

**5.18 Tax Status; Non-Jurisdictional Entities.**

**5.18.1 Tax Status.** Each Party shall cooperate with the other Parties to maintain the other Parties' tax status. Nothing in this Agreement is intended to adversely affect the tax status of any Party including the status of NYISO, or the status of any Connecting Transmission Owner with respect to the issuance of bonds including, but not limited to, Local Furnishing Bonds. Notwithstanding any other provisions of this Agreement, LIPA, NYPA and Consolidated Edison Company of New York, Inc. shall not be required to comply with any provisions of this Agreement that would result in the loss of tax-exempt status of any of their Tax-Exempt Bonds or impair their ability to issue future tax-exempt obligations. For purposes of this provision, Tax-Exempt Bonds shall include the obligations of the Long Island Power Authority, NYPA and Consolidated Edison Company of New York, Inc., the interest on which is not included in gross income under the Internal Revenue Code.

**5.18.2 Non-Jurisdictional Entities.** LIPA and NYPA do not waive their exemptions, pursuant to Section 201(f) of the FPA, from Commission jurisdiction with respect to the Commission's exercise of the FPA's general ratemaking authority.

**5.19 Modification.**

**5.19.1 General.** Either the Developer or Connecting Transmission Owner may undertake modifications to its facilities covered by this Agreement. If either the Developer or Connecting Transmission Owner plans to undertake a modification that reasonably may be expected to affect the other Party's facilities, that Party shall provide to the other Party, and to NYISO, sufficient information regarding such modification so that the other Party and NYISO may evaluate the potential impact of such modification prior to commencement of the work. Such information shall be deemed to be Confidential Information hereunder and shall include information concerning the timing of such modifications and whether such modifications are expected to interrupt the flow of electricity from the Large Generating Facility. The Party desiring to perform such work shall provide the relevant drawings, plans, and specifications to the other Party and NYISO at least ninety (90) Calendar Days in advance of the commencement of the work or such shorter period upon which the Parties may agree, which agreement shall not unreasonably be withheld, conditioned or delayed.

In the case of Large Generating Facility modifications that do not require Developer to submit an Interconnection Request, the NYISO shall provide, within sixty (60) Calendar Days (or such other time as the Parties may agree), an estimate of any additional modifications to the New York State Transmission System, Connecting Transmission Owner's Attachment Facilities or System Upgrade Facilities or System Deliverability Upgrades necessitated by such Developer modification and a good faith estimate of the costs thereof. The Developer shall be responsible for the cost of any such additional modifications, including the cost of studying the impact of the Developer modification.

**5.19.2 Standards.** Any additions, modifications, or replacements made to a Party's facilities shall be designed, constructed and operated in accordance with this Agreement, NYISO requirements and Good Utility Practice.

**5.19.3 Modification Costs.** Developer shall not be assigned the costs of any additions, modifications, or replacements that Connecting Transmission Owner makes to the Connecting Transmission Owner's Attachment Facilities or the New York State Transmission System to facilitate the interconnection of a third party to the Connecting Transmission Owner's Attachment Facilities or the New York State Transmission System, or to provide Transmission Service to a third party under the NYISO OATT, except in accordance with the cost allocation procedures in Attachment S of the NYISO OATT. Developer shall be responsible for the costs of any

additions, modifications, or replacements to the Developer Attachment Facilities that may be necessary to maintain or upgrade such Developer Attachment Facilities consistent with Applicable Laws and Regulations, Applicable Reliability Standards or Good Utility Practice.

**ARTICLE 6. TESTING AND INSPECTION**

- 6.1 Pre-Commercial Operation Date Testing and Modifications.** Prior to the Commercial Operation Date, the Connecting Transmission Owner shall test the Connecting Transmission Owner's Attachment Facilities and System Upgrade Facilities and System Deliverability Upgrades and Developer shall test the Large Generating Facility and the Developer Attachment Facilities to ensure their safe and reliable operation. Similar testing may be required after initial operation. Developer and Connecting Transmission Owner shall each make any modifications to its facilities that are found to be necessary as a result of such testing. Developer shall bear the cost of all such testing and modifications. Developer shall generate test energy at the Large Generating Facility only if it has arranged for the injection of such test energy in accordance with NYISO procedures.
- 6.2 Post-Commercial Operation Date Testing and Modifications.** Developer and Connecting Transmission Owner shall each at its own expense perform routine inspection and testing of its facilities and equipment in accordance with Good Utility Practice and Applicable Reliability Standards as may be necessary to ensure the continued interconnection of the Large Generating Facility with the New York State Transmission System in a safe and reliable manner. Developer and Connecting Transmission Owner shall each have the right, upon advance written notice, to require reasonable additional testing of the other Party's facilities, at the requesting Party's expense, as may be in accordance with Good Utility Practice.
- 6.3 Right to Observe Testing.** Developer and Connecting Transmission Owner shall each notify the other Party, and the NYISO, in advance of its performance of tests of its Attachment Facilities. The other Party, and the NYISO, shall each have the right, at its own expense, to observe such testing.
- 6.4 Right to Inspect.** Developer and Connecting Transmission Owner shall each have the right, but shall have no obligation to: (i) observe the other Party's tests and/or inspection of any of its System Protection Facilities and other protective equipment, including Power System Stabilizers; (ii) review the settings of the other Party's System Protection Facilities and other protective equipment; and (iii) review the other Party's maintenance records relative to the Attachment Facilities, the System Protection Facilities and other protective equipment. NYISO shall have these same rights of inspection as to the facilities and equipment of Developer and Connecting Transmission Owner. A Party may exercise these rights from time to time as it deems necessary upon reasonable notice to the other Party. The exercise or non-exercise by a Party of any such rights shall not be construed as an endorsement or confirmation of any element or condition of the

## SERVICE AGREEMENT NO. 1774

Attachment Facilities or the System Protection Facilities or other protective equipment or the operation thereof, or as a warranty as to the fitness, safety, desirability, or reliability of same. Any information that a Party obtains through the exercise of any of its rights under this Article 6.4 shall be treated in accordance with Article 22 of this Agreement and Attachment F to the NYISO OATT.

### ARTICLE 7. METERING

- 7.1 General.** Developer and Connecting Transmission Owner shall each comply with applicable requirements of NYISO and the New York Public Service Commission when exercising its rights and fulfilling its responsibilities under this Article 7. Unless otherwise agreed by the Connecting Transmission Owner and NYISO approved meter service provider and Developer, the Connecting Transmission Owner shall install Metering Equipment at the Point of Interconnection prior to any operation of the Large Generating Facility and shall own, operate, test and maintain such Metering Equipment. Net power flows including MW and MVAR, MWHR and loss profile data to and from the Large Generating Facility shall be measured at the Point of Interconnection. Connecting Transmission Owner shall provide metering quantities, in analog and/or digital form, as required, to Developer or NYISO upon request. Where the Point of Interconnection for the Large Generating Facility is other than the generator terminal, the Developer shall also provide gross MW and MVAR quantities at the generator terminal. Developer shall bear all reasonable documented costs associated with the purchase, installation, operation, testing and maintenance of the Metering Equipment.
- 7.2 Check Meters.** Developer, at its option and expense, may install and operate, on its premises and on its side of the Point of Interconnection, one or more check meters to check Connecting Transmission Owner's meters. Such check meters shall be for check purposes only and shall not be used for the measurement of power flows for purposes of this Agreement, except as provided in Article 7.4 below. The check meters shall be subject at all reasonable times to inspection and examination by Connecting Transmission Owner or its designee. The installation, operation and maintenance thereof shall be performed entirely by Developer in accordance with Good Utility Practice.
- 7.3 Standards.** Connecting Transmission Owner shall install, calibrate, and test revenue quality Metering Equipment including potential transformers and current transformers in accordance with applicable ANSI and PSC standards as detailed in the NYISO Control Center Communications Manual and in the NYISO Revenue Metering Requirements Manual.
- 7.4 Testing of Metering Equipment.** Connecting Transmission Owner shall inspect and test all of its Metering Equipment upon installation and at least once every two (2) years thereafter. If requested to do so by NYISO or Developer, Connecting Transmission Owner shall, at Developer's expense, inspect or test Metering Equipment more frequently than every two (2) years. Connecting Transmission Owner shall give reasonable notice of the time when any inspection or test shall take place, and Developer and NYISO may

## SERVICE AGREEMENT NO. 1774

have representatives present at the test or inspection. If at any time Metering Equipment is found to be inaccurate or defective, it shall be adjusted, repaired or replaced at Developer's expense, in order to provide accurate metering, unless the inaccuracy or defect is due to Connecting Transmission Owner's failure to maintain, then Connecting Transmission Owner shall pay. If Metering Equipment fails to register, or if the measurement made by Metering Equipment during a test varies by more than two percent from the measurement made by the standard meter used in the test, Connecting Transmission Owner shall adjust the measurements by correcting all measurements for the period during which Metering Equipment was in error by using Developer's check meters, if installed. If no such check meters are installed or if the period cannot be reasonably ascertained, the adjustment shall be for the period immediately preceding the test of the Metering Equipment equal to one-half the time from the date of the last previous test of the Metering Equipment. The NYISO shall reserve the right to review all associated metering equipment installation on the Developer's or Connecting Transmission Owner's property at any time.

- 7.5 Metering Data.** At Developer's expense, the metered data shall be telemetered to one or more locations designated by Connecting Transmission Owner, Developer and NYISO. Such telemetered data shall be used, under normal operating conditions, as the official measurement of the amount of energy delivered from the Large Generating Facility to the Point of Interconnection.

## ARTICLE 8. COMMUNICATIONS

- 8.1 Developer Obligations.** In accordance with applicable NYISO requirements, Developer shall maintain satisfactory operating communications with Connecting Transmission Owner and NYISO. Developer shall provide standard voice line, dedicated voice line and facsimile communications at its Large Generating Facility control room or central dispatch facility through use of either the public telephone system, or a voice communications system that does not rely on the public telephone system. Developer shall also provide the dedicated data circuit(s) necessary to provide Developer data to Connecting Transmission Owner and NYISO as set forth in Appendix D hereto. The data circuit(s) shall extend from the Large Generating Facility to the location(s) specified by Connecting Transmission Owner and NYISO. Any required maintenance of such communications equipment shall be performed by Developer. Operational communications shall be activated and maintained under, but not be limited to, the following events: system paralleling or separation, scheduled and unscheduled shutdowns, equipment clearances, and hourly and daily load data.
- 8.2 Remote Terminal Unit.** Prior to the Initial Synchronization Date of the Large Generating Facility, a Remote Terminal Unit, or equivalent data collection and transfer equipment acceptable to the Parties, shall be installed by Developer, or by Connecting Transmission Owner at Developer's expense, to gather accumulated and instantaneous data to be telemetered to the location(s) designated by Connecting Transmission Owner and NYISO through use of a dedicated point-to-point data circuit(s) as indicated in

## SERVICE AGREEMENT NO. 1774

Article 8.1. The communication protocol for the data circuit(s) shall be specified by Connecting Transmission Owner and NYISO. Instantaneous bi-directional analog real power and reactive power flow information must be telemetered directly to the location(s) specified by Connecting Transmission Owner and NYISO.

Each Party will promptly advise the appropriate other Party if it detects or otherwise learns of any metering, telemetry or communications equipment errors or malfunctions that require the attention and/or correction by that other Party. The Party owning such equipment shall correct such error or malfunction as soon as reasonably feasible.

- 8.3 No Annexation.** Any and all equipment placed on the premises of a Party shall be and remain the property of the Party providing such equipment regardless of the mode and manner of annexation or attachment to real property, unless otherwise mutually agreed by the Party providing such equipment and the Party receiving such equipment.

### ARTICLE 9. OPERATIONS

- 9.1 General.** Each Party shall comply with Applicable Laws and Regulations and Applicable Reliability Standards. Each Party shall provide to the other Parties all information that may reasonably be required by the other Parties to comply with Applicable Laws and Regulations and Applicable Reliability Standards.
- 9.2 NYISO and Connecting Transmission Owner Obligations.** Connecting Transmission Owner and NYISO shall cause the New York State Transmission System and the Connecting Transmission Owner's Attachment Facilities to be operated, maintained and controlled in a safe and reliable manner in accordance with this Agreement and the NYISO Tariffs. Connecting Transmission Owner and NYISO may provide operating instructions to Developer consistent with this Agreement, NYISO procedures and Connecting Transmission Owner's operating protocols and procedures as they may change from time to time. Connecting Transmission Owner and NYISO will consider changes to their respective operating protocols and procedures proposed by Developer.
- 9.3 Developer Obligations.** Developer shall at its own expense operate, maintain and control the Large Generating Facility and the Developer Attachment Facilities in a safe and reliable manner and in accordance with this Agreement. Developer shall operate the Large Generating Facility and the Developer Attachment Facilities in accordance with NYISO and Connecting Transmission Owner requirements, as such requirements are set forth or referenced in Appendix C hereto. Appendix C will be modified to reflect changes to the requirements as they may change from time to time. Any Party may request that the appropriate other Party or Parties provide copies of the requirements set forth or referenced in Appendix C hereto.
- 9.4 Start-Up and Synchronization.** Consistent with the mutually acceptable procedures of the Developer and Connecting Transmission Owner, the Developer is responsible for the

## SERVICE AGREEMENT NO. 1774

proper synchronization of the Large Generating Facility to the New York State Transmission System in accordance with NYISO and Connecting Transmission Owner procedures and requirements.

### **9.5 Real and Reactive Power Control.**

**9.5.1 Power Factor Design Criteria.** Developer shall design the Large Generating Facility to maintain an effective power delivery at demonstrated maximum net capability at the Point of Interconnection at a power factor within the range established by the Connecting Transmission Owner on a comparable basis, until NYISO has established different requirements that apply to all generators in the New York Control Area on a comparable basis.

The Developer shall design and maintain the plant auxiliary systems to operate safely throughout the entire real and reactive power design range.

The Connecting Transmission Owner shall not unreasonably restrict or condition the reactive power production or absorption of the Large Generating Facility in accordance with Good Utility Practice.

**9.5.2 Voltage Schedules.** Once the Developer has synchronized the Large Generating Facility with the New York State Transmission System, NYISO shall require Developer to operate the Large Generating Facility to produce or absorb reactive power within the design capability of the Large Generating Facility set forth in Article 9.5.1 (Power Factor Design Criteria). NYISO's voltage schedules shall treat all sources of reactive power in the New York Control Area in an equitable and not unduly discriminatory manner. NYISO shall exercise Reasonable Efforts to provide Developer with such schedules in accordance with NYISO procedures, and may make changes to such schedules as necessary to maintain the reliability of the New York State Transmission System. Developer shall operate the Large Generating Facility to maintain the specified output voltage or power factor at the Point of Interconnection within the design capability of the Large Generating Facility set forth in Article 9.5.1 (Power Factor Design Criteria) as directed by the Connecting Transmission Owner's System Operator or the NYISO. If Developer is unable to maintain the specified voltage or power factor, it shall promptly notify NYISO.

**9.5.3 Payment for Reactive Power.** NYISO shall pay Developer for reactive power or voltage support service that Developer provides from the Large

## SERVICE AGREEMENT NO. 1774

Generating Facility in accordance with the provisions of Rate Schedule 2 of the NYISO Services Tariff.

**9.5.4 Governors and Regulators.** Whenever the Large Generating Facility is operated in parallel with the New York State Transmission System, the turbine speed governors and automatic voltage regulators shall be in automatic operation at all times. If the Large Generating Facility's speed governors or automatic voltage regulators are not capable of such automatic operation, the Developer shall immediately notify NYISO, or its designated representative, and ensure that such Large Generating Facility's real and reactive power are within the design capability of the Large Generating Facility's generating unit(s) and steady state stability limits and NYISO system operating (thermal, voltage and transient stability) limits. Developer shall not cause its Large Generating Facility to disconnect automatically or instantaneously from the New York State Transmission System or trip any generating unit comprising the Large Generating Facility for an under or over frequency condition unless the abnormal frequency condition persists for a time period beyond the limits set forth in ANSI/IEEE Standard C37.106, or such other standard as applied to other generators in the New York Control Area on a comparable basis.

## **9.6 Outages and Interruptions.**

### **9.6.1 Outages.**

**9.6.1.1 Outage Authority and Coordination.** Developer and Connecting Transmission Owner may each, in accordance with NYISO procedures and Good Utility Practice and in coordination with the other Party, remove from service any of its respective Attachment Facilities or System Upgrade Facilities and System Deliverability Upgrades that may impact the other Party's facilities as necessary to perform maintenance or testing or to install or replace equipment. Absent an Emergency State, the Party scheduling a removal of such facility(ies) from service will use Reasonable Efforts to schedule such removal on a date and time mutually acceptable to both the Developer and the Connecting Transmission Owner. In all circumstances either Party planning to remove such facility(ies) from service shall use Reasonable Efforts to minimize the effect on the other Party of such removal.

**9.6.1.2 Outage Schedules.** The Connecting Transmission Owner shall post scheduled outages of its transmission facilities on the NYISO OASIS. Developer shall submit its planned maintenance schedules for the

Large Generating Facility to Connecting Transmission Owner and NYISO for a minimum of a rolling thirty-six month period. Developer shall update its planned maintenance schedules as necessary. NYISO may direct, or the Connecting Transmission Owner may request, Developer to reschedule its maintenance as necessary to maintain the reliability of the New York State Transmission System. Compensation to Developer for any additional direct costs that the Developer incurs as a result of rescheduling maintenance, including any additional overtime, breaking of maintenance contracts or other costs above and beyond the cost the Developer would have incurred absent the request to reschedule maintenance, shall be in accordance with the NYISO OATT. Developer will not be eligible to receive compensation, if during the twelve (12) months prior to the date of the scheduled maintenance, the Developer had modified its schedule of maintenance activities other than at the direction of the NYISO or request of the Connecting Transmission Owner.

**9.6.1.3 Outage Restoration.** If an outage on the Attachment Facilities or System Upgrade Facilities or System Deliverability Upgrades of the Connecting Transmission Owner or Developer adversely affects the other Party's operations or facilities, the Party that owns the facility that is out of service shall use Reasonable Efforts to promptly restore such facility(ies) to a normal operating condition consistent with the nature of the outage. The Party that owns the facility that is out of service shall provide the other Party and NYISO, to the extent such information is known, information on the nature of the Emergency State, an estimated time of restoration, and any corrective actions required. Initial verbal notice shall be followed up as soon as practicable with written notice explaining the nature of the outage.

**9.6.2 Interruption of Service.** If required by Good Utility Practice or Applicable Reliability Standards to do so, the NYISO or Connecting Transmission Owner may require Developer to interrupt or reduce production of electricity if such production of electricity could adversely affect the ability of NYISO and Connecting Transmission Owner to perform such activities as are necessary to safely and reliably operate and maintain the New York State Transmission System. The following provisions shall apply to any interruption or reduction permitted under this Article 9.6.2:

**9.6.2.1** The interruption or reduction shall continue only for so long as reasonably necessary under Good Utility Practice;

## SERVICE AGREEMENT NO. 1774

- 9.6.2.2** Any such interruption or reduction shall be made on an equitable, non-discriminatory basis with respect to all generating facilities directly connected to the New York State Transmission System;
- 9.6.2.3** When the interruption or reduction must be made under circumstances which do not allow for advance notice, NYISO or Connecting Transmission Owner shall notify Developer by telephone as soon as practicable of the reasons for the curtailment, interruption, or reduction, and, if known, its expected duration. Telephone notification shall be followed by written notification as soon as practicable;
- 9.6.2.4** Except during the existence of an Emergency State, when the interruption or reduction can be scheduled without advance notice, NYISO or Connecting Transmission Owner shall notify Developer in advance regarding the timing of such scheduling and further notify Developer of the expected duration. NYISO or Connecting Transmission Owner shall coordinate with each other and the Developer using Good Utility Practice to schedule the interruption or reduction during periods of least impact to the Developer, the Connecting Transmission Owner and the New York State Transmission System;
- 9.6.2.5** The Parties shall cooperate and coordinate with each other to the extent necessary in order to restore the Large Generating Facility, Attachment Facilities, and the New York State Transmission System to their normal operating state, consistent with system conditions and Good Utility Practice.

**9.6.3 Under-Frequency and Over Frequency Conditions.** The New York State Transmission System is designed to automatically activate a load-shed program as required by the NPCC in the event of an under-frequency system disturbance. Developer shall implement under-frequency and over-frequency relay set points for the Large Generating Facility as required by the NPCC to ensure “ride through” capability of the New York State Transmission System. Large Generating Facility response to frequency deviations of predetermined magnitudes, both under-frequency and over-frequency deviations, shall be studied and coordinated with the NYISO and Connecting Transmission Owner in accordance with Good Utility Practice. The term “ride through” as used herein shall mean the ability of a Generating Facility to stay connected to and synchronized with the New York State Transmission System during system disturbances within a range of under-frequency and over-frequency conditions, in accordance with Good Utility Practice and with NPCC Directory # 12 .

**9.6.4 System Protection and Other Control Requirements.**

- 9.6.4.1 System Protection Facilities.** Developer shall, at its expense, install, operate and maintain System Protection Facilities as a part of the Large Generating Facility or Developer Attachment Facilities. Connecting Transmission Owner shall install at Developer's expense any System Protection Facilities that may be required on the Connecting Transmission Owner Attachment Facilities or the New York State Transmission System as a result of the interconnection of the Large Generating Facility and Developer Attachment Facilities.
- 9.6.4.2** The protection facilities of both the Developer and Connecting Transmission Owner shall be designed and coordinated with other systems in accordance with Good Utility Practice and Applicable Reliability Standards.
- 9.6.4.3** The Developer and Connecting Transmission Owner shall each be responsible for protection of its respective facilities consistent with Good Utility Practice and Applicable Reliability Standards.
- 9.6.4.4** The protective relay design of the Developer and Connecting Transmission Owner shall each incorporate the necessary test switches to perform the tests required in Article 6 of this Agreement. The required test switches will be placed such that they allow operation of lockout relays while preventing breaker failure schemes from operating and causing unnecessary breaker operations and/or the tripping of the Developer's Large Generating Facility.
- 9.6.4.5** The Developer and Connecting Transmission Owner will each test, operate and maintain System Protection Facilities in accordance with Good Utility Practice and NPCC criteria.
- 9.6.4.6** Prior to the In-Service Date, and again prior to the Commercial Operation Date, the Developer and Connecting Transmission Owner shall each perform, or their agents shall perform, a complete calibration test and functional trip test of the System Protection Facilities. At intervals suggested by Good Utility Practice and following any apparent malfunction of the System Protection Facilities, the Developer and Connecting Transmission Owner shall each perform both calibration and functional trip tests of its System Protection Facilities. These tests do not require the tripping of any in-service generation unit. These tests do, however, require that all protective relays and lockout contacts be activated.

**9.6.5 Requirements for Protection.** In compliance with NPCC requirements and Good Utility Practice, Developer shall provide, install, own, and maintain relays, circuit breakers and all other devices necessary to remove any fault contribution of the Large Generating Facility to any short circuit occurring on the New York State Transmission System not otherwise isolated by Connecting Transmission Owner's equipment, such that the removal of the fault contribution shall be coordinated with the protective requirements of the New York State Transmission System. Such protective equipment shall include, without limitation, a disconnecting device or switch with load-interrupting capability located between the Large Generating Facility and the New York State Transmission System at a site selected upon mutual agreement (not to be unreasonably withheld, conditioned or delayed) of the Developer and Connecting Transmission Owner. Developer shall be responsible for protection of the Large Generating Facility and Developer's other equipment from such conditions as negative sequence currents, over- or under-frequency, sudden load rejection, over- or under-voltage, and generator loss-of-field. Developer shall be solely responsible to disconnect the Large Generating Facility and Developer's other equipment if conditions on the New York State Transmission System could adversely affect the Large Generating Facility.

**9.6.6 Power Quality.** Neither the facilities of Developer nor the facilities of Connecting Transmission Owner shall cause excessive voltage flicker nor introduce excessive distortion to the sinusoidal voltage or current waves as defined by ANSI Standard C84.1-1989, in accordance with IEEE Standard 519, or any applicable superseding electric industry standard. In the event of a conflict between ANSI Standard C84.1-1989, or any applicable superseding electric industry standard, ANSI Standard C84.1-1989, or the applicable superseding electric industry standard, shall control.

**9.7 Switching and Tagging Rules.** The Developer and Connecting Transmission Owner shall each provide the other Party a copy of its switching and tagging rules that are applicable to the other Party's activities. Such switching and tagging rules shall be developed on a nondiscriminatory basis. The Parties shall comply with applicable switching and tagging rules, as amended from time to time, in obtaining clearances for work or for switching operations on equipment.

**9.8 Use of Attachment Facilities by Third Parties.**

**9.8.1 Purpose of Attachment Facilities.** Except as may be required by Applicable Laws and Regulations, or as otherwise agreed to among the Parties, the Attachment Facilities shall be constructed for the sole purpose

## SERVICE AGREEMENT NO. 1774

of interconnecting the Large Generating Facility to the New York State Transmission System and shall be used for no other purpose.

**9.8.2 Third Party Users.** If required by Applicable Laws and Regulations or if the Parties mutually agree, such agreement not to be unreasonably withheld, to allow one or more third parties to use the Connecting Transmission Owner's Attachment Facilities, or any part thereof, Developer will be entitled to compensation for the capital expenses it incurred in connection with the Attachment Facilities based upon the pro rata use of the Attachment Facilities by Connecting Transmission Owner, all third party users, and Developer, in accordance with Applicable Laws and Regulations or upon some other mutually-agreed upon methodology. In addition, cost responsibility for ongoing costs, including operation and maintenance costs associated with the Attachment Facilities, will be allocated between Developer and any third party users based upon the pro rata use of the Attachment Facilities by Connecting Transmission Owner, all third party users, and Developer, in accordance with Applicable Laws and Regulations or upon some other mutually agreed upon methodology. If the issue of such compensation or allocation cannot be resolved through such negotiations, it shall be submitted to FERC for resolution.

**9.9 Disturbance Analysis Data Exchange.** The Parties will cooperate with one another and the NYISO in the analysis of disturbances to either the Large Generating Facility or the New York State Transmission System by gathering and providing access to any information relating to any disturbance, including information from disturbance recording equipment, protective relay targets, breaker operations and sequence of events records, and any disturbance information required by Good Utility Practice.

## ARTICLE 10. MAINTENANCE

**10.1 Connecting Transmission Owner Obligations.** Connecting Transmission Owner shall maintain its transmission facilities and Attachment Facilities in a safe and reliable manner and in accordance with this Agreement.

**10.2 Developer Obligations.** Developer shall maintain its Large Generating Facility and Attachment Facilities in a safe and reliable manner and in accordance with this Agreement.

**10.3 Coordination.** The Developer and Connecting Transmission Owner shall confer regularly to coordinate the planning, scheduling and performance of preventive and corrective maintenance on the Large Generating Facility and the Attachment Facilities. The Developer and Connecting Transmission Owner shall keep NYISO fully informed of

## SERVICE AGREEMENT NO. 1774

the preventive and corrective maintenance that is planned, and shall schedule all such maintenance in accordance with NYISO procedures.

- 10.4 Secondary Systems.** The Developer and Connecting Transmission Owner shall each cooperate with the other in the inspection, maintenance, and testing of control or power circuits that operate below 600 volts, AC or DC, including, but not limited to, any hardware, control or protective devices, cables, conductors, electric raceways, secondary equipment panels, transducers, batteries, chargers, and voltage and current transformers that directly affect the operation of Developer or Connecting Transmission Owner's facilities and equipment which may reasonably be expected to impact the other Party. The Developer and Connecting Transmission Owner shall each provide advance notice to the other Party, and to NYISO, before undertaking any work on such circuits, especially on electrical circuits involving circuit breaker trip and close contacts, current transformers, or potential transformers.
- 10.5 Operating and Maintenance Expenses.** Subject to the provisions herein addressing the use of facilities by others, and except for operations and maintenance expenses associated with modifications made for providing interconnection or transmission service to a third party and such third party pays for such expenses, Developer shall be responsible for all reasonable expenses including overheads, associated with: (1) owning, operating, maintaining, repairing, and replacing Developer Attachment Facilities; and (2) operation, maintenance, repair and replacement of Connecting Transmission Owner's Attachment Facilities. The Connecting Transmission Owner shall be entitled to the recovery of incremental operating and maintenance expenses that it incurs associated with System Upgrade Facilities and System Deliverability Upgrades if and to the extent provided for under Attachment S to the NYISO OATT.

## ARTICLE 11. PERFORMANCE OBLIGATION

- 11.1 Developer Attachment Facilities.** Developer shall design, procure, construct, install, own and/or control the Developer Attachment Facilities described in Appendix A hereto, at its sole expense.
- 11.2 Connecting Transmission Owner's Attachment Facilities.** Connecting Transmission Owner shall design, procure, construct, install, own and/or control the Connecting Transmission Owner's Attachment Facilities described in Appendix A hereto, at the sole expense of the Developer.
- 11.3 System Upgrade Facilities and System Deliverability Upgrades.** Connecting Transmission Owner shall design, procure, construct, install, and own the System Upgrade Facilities and System Deliverability Upgrades described in Appendix A hereto. The responsibility of the Developer for costs related to System Upgrade Facilities and System Deliverability Upgrades shall be determined in accordance with the provisions of Attachment S to the NYISO OATT.

## SERVICE AGREEMENT NO. 1774

**11.4 Special Provisions for Affected Systems.** For the re-payment of amounts advanced to Affected System Operator for System Upgrade Facilities or System Deliverability Upgrades, the Developer and Affected System Operator shall enter into an agreement that provides for such re-payment, but only if responsibility for the cost of such System Upgrade Facilities or System Deliverability Upgrades is not to be allocated in accordance with Attachment S to the NYISO OATT. The agreement shall specify the terms governing payments to be made by the Developer to the Affected System Operator as well as the re-payment by the Affected System Operator.

**11.5 Provision of Security.** At least thirty (30) Calendar Days prior to the commencement of the procurement, installation, or construction of a discrete portion of a Connecting Transmission Owner's Attachment Facilities, Developer shall provide Connecting Transmission Owner, at Developer's option, a guarantee, a surety bond, letter of credit or other form of security that is reasonably acceptable to Connecting Transmission Owner and is consistent with the Uniform Commercial Code of the jurisdiction identified in Article 14.2.1 of this Agreement. Such security for payment shall be in an amount sufficient to cover the cost for the Developer's share of constructing, procuring and installing the applicable portion of Connecting Transmission Owner's Attachment Facilities, and shall be reduced on a dollar-for-dollar basis for payments made to Connecting Transmission Owner for these purposes.

In addition:

**11.5.1** The guarantee must be made by an entity that meets the commercially reasonable creditworthiness requirements of Connecting Transmission Owner, and contains terms and conditions that guarantee payment of any amount that may be due from Developer, up to an agreed-to maximum amount.

**11.5.2** The letter of credit must be issued by a financial institution reasonably acceptable to Connecting Transmission Owner and must specify a reasonable expiration date.

**11.5.3** The surety bond must be issued by an insurer reasonably acceptable to Connecting Transmission Owner and must specify a reasonable expiration date.

**11.5.4** Attachment S to the NYISO OATT shall govern the Security that Developer provides for System Upgrade Facilities and System Deliverability Upgrades.

**11.6 Developer Compensation for Emergency Services.** If, during an Emergency State, the Developer provides services at the request or direction of the NYISO or Connecting

## SERVICE AGREEMENT NO. 1774

Transmission Owner, the Developer will be compensated for such services in accordance with the NYISO Services Tariff.

- 11.7 Line Outage Costs.** Notwithstanding anything in the NYISO OATT to the contrary, the Connecting Transmission Owner may propose to recover line outage costs associated with the installation of Connecting Transmission Owner's Attachment Facilities or System Upgrade Facilities or System Deliverability Upgrades on a case-by-case basis.

### ARTICLE 12. INVOICE

- 12.1 General.** The Developer and Connecting Transmission Owner shall each submit to the other Party, on a monthly basis, invoices of amounts due for the preceding month. Each invoice shall state the month to which the invoice applies and fully describe the services and equipment provided. The Developer and Connecting Transmission Owner may discharge mutual debts and payment obligations due and owing to each other on the same date through netting, in which case all amounts one Party owes to the other Party under this Agreement, including interest payments or credits, shall be netted so that only the net amount remaining due shall be paid by the owing Party. Notwithstanding anything in this Article 12 to the contrary, the procedure for invoicing and payment for the Common System Upgrade Facilities as described in Appendix A Section III to this Agreement shall be as set forth in Appendix H to this Agreement.
- 12.2 Final Invoice.** Within six months after completion of the construction of the Connecting Transmission Owner's Attachment Facilities and the System Upgrade Facilities and System Deliverability Upgrades, Connecting Transmission Owner shall provide an invoice of the final cost of the construction of the Connecting Transmission Owner's Attachment Facilities and the System Upgrade Facilities and System Deliverability Upgrades, determined in accordance with Attachment S to the NYISO OATT, and shall set forth such costs in sufficient detail to enable Developer to compare the actual costs with the estimates and to ascertain deviations, if any, from the cost estimates. Connecting Transmission Owner shall refund to Developer any amount by which the actual payment by Developer for estimated costs exceeds the actual costs of construction within thirty (30) Calendar Days of the issuance of such final construction invoice.
- 12.3 Payment.** Invoices shall be rendered to the paying Party at the address specified in Appendix F hereto. The Party receiving the invoice shall pay the invoice within thirty (30) Calendar Days of receipt. All payments shall be made in immediately available funds payable to the other Party, or by wire transfer to a bank named and account designated by the invoicing Party. Payment of invoices will not constitute a waiver of any rights or claims the paying Party may have under this Agreement.
- 12.4 Disputes.** In the event of a billing dispute between Connecting Transmission Owner and Developer, Connecting Transmission Owner shall continue to perform under this Agreement as long as Developer: (i) continues to make all payments not in dispute; and (ii) pays to Connecting Transmission Owner or into an independent escrow account the

## SERVICE AGREEMENT NO. 1774

portion of the invoice in dispute, pending resolution of such dispute. If Developer fails to meet these two requirements for continuation of service, then Connecting Transmission Owner may provide notice to Developer of a Default pursuant to Article 17. Within thirty (30) Calendar Days after the resolution of the dispute, the Party that owes money to the other Party shall pay the amount due with interest calculated in accord with the methodology set forth in FERC's Regulations at 18 C.F.R. § 35.19a(a)(2)(iii).

### ARTICLE 13. EMERGENCIES

- 13.1 Obligations.** Each Party shall comply with the Emergency State procedures of NYISO, the applicable Reliability Councils, Applicable Laws and Regulations, and any emergency procedures agreed to by the NYISO Operating Committee.
- 13.2 Notice.** NYISO or, as applicable, Connecting Transmission Owner shall notify Developer promptly when it becomes aware of an Emergency State that affects the Connecting Transmission Owner's Attachment Facilities or the New York State Transmission System that may reasonably be expected to affect Developer's operation of the Large Generating Facility or the Developer's Attachment Facilities. Developer shall notify NYISO and Connecting Transmission Owner promptly when it becomes aware of an Emergency State that affects the Large Generating Facility or the Developer Attachment Facilities that may reasonably be expected to affect the New York State Transmission System or the Connecting Transmission Owner's Attachment Facilities. To the extent information is known, the notification shall describe the Emergency State, the extent of the damage or deficiency, the expected effect on the operation of Developer's or Connecting Transmission Owner's facilities and operations, its anticipated duration and the corrective action taken and/or to be taken. The initial notice shall be followed as soon as practicable with written notice.
- 13.3 Immediate Action.** Unless, in Developer's reasonable judgment, immediate action is required, Developer shall obtain the consent of Connecting Transmission Owner, such consent to not be unreasonably withheld, prior to performing any manual switching operations at the Large Generating Facility or the Developer Attachment Facilities in response to an Emergency State either declared by NYISO, Connecting Transmission Owner or otherwise regarding New York State Transmission System.
- 13.4 NYISO and Connecting Transmission Owner Authority.**
- 13.4.1 General.** NYISO or Connecting Transmission Owner may take whatever actions with regard to the New York State Transmission System or the Connecting Transmission Owner's Attachment Facilities it deems necessary during an Emergency State in order to (i) preserve public health and safety, (ii) preserve the reliability of the New York State Transmission System or the Connecting Transmission Owner's Attachment Facilities, (iii) limit or prevent damage, and (iv) expedite restoration of service.

NYISO and Connecting Transmission Owner shall use Reasonable Efforts to minimize the effect of such actions or inactions on the Large Generating Facility or the Developer Attachment Facilities. NYISO or Connecting Transmission Owner may, on the basis of technical considerations, require the Large Generating Facility to mitigate an Emergency State by taking actions necessary and limited in scope to remedy the Emergency State, including, but not limited to, directing Developer to shut-down, start-up, increase or decrease the real or reactive power output of the Large Generating Facility; implementing a reduction or disconnection pursuant to Article 13.4.2; directing the Developer to assist with blackstart (if available) or restoration efforts; or altering the outage schedules of the Large Generating Facility and the Developer Attachment Facilities. Developer shall comply with all of the NYISO and Connecting Transmission Owner's operating instructions concerning Large Generating Facility real power and reactive power output within the manufacturer's design limitations of the Large Generating Facility's equipment that is in service and physically available for operation at the time, in compliance with Applicable Laws and Regulations.

**13.4.2 Reduction and Disconnection.** NYISO or Connecting Transmission Owner may reduce Energy Resource Interconnection Service or disconnect the Large Generating Facility or the Developer Attachment Facilities, when such reduction or disconnection is necessary under Good Utility Practice due to an Emergency State. These rights are separate and distinct from any right of Curtailment of NYISO pursuant to the NYISO OATT. When NYISO or Connecting Transmission Owner can schedule the reduction or disconnection in advance, NYISO or Connecting Transmission Owner shall notify Developer of the reasons, timing and expected duration of the reduction or disconnection. NYISO or Connecting Transmission Owner shall coordinate with the Developer using Good Utility Practice to schedule the reduction or disconnection during periods of least impact to the Developer and the New York State Transmission System. Any reduction or disconnection shall continue only for so long as reasonably necessary under Good Utility Practice. The Parties shall cooperate with each other to restore the Large Generating Facility, the Attachment Facilities, and the New York State Transmission System to their normal operating state as soon as practicable consistent with Good Utility Practice.

**13.5 Developer Authority.** Consistent with Good Utility Practice and this Agreement, the Developer may take whatever actions or inactions with regard to the Large Generating Facility or the Developer Attachment Facilities during an Emergency State in order to (i) preserve public health and safety, (ii) preserve the reliability of the Large Generating Facility or the Developer Attachment Facilities, (iii) limit or prevent damage, and (iv) expedite restoration of service. Developer shall use Reasonable Efforts to minimize the effect of such actions or inactions on the New York State Transmission System and the

## SERVICE AGREEMENT NO. 1774

Connecting Transmission Owner's Attachment Facilities. NYISO and Connecting Transmission Owner shall use Reasonable Efforts to assist Developer in such actions.

- 13.6 Limited Liability.** Except as otherwise provided in Article 11.6 of this Agreement, no Party shall be liable to another Party for any action it takes in responding to an Emergency State so long as such action is made in good faith and is consistent with Good Utility Practice and the NYISO Tariffs.

## ARTICLE 14. REGULATORY REQUIREMENTS AND GOVERNING LAW

- 14.1 Regulatory Requirements.** Each Party's obligations under this Agreement shall be subject to its receipt of any required approval or certificate from one or more Governmental Authorities in the form and substance satisfactory to the applying Party, or the Party making any required filings with, or providing notice to, such Governmental Authorities, and the expiration of any time period associated therewith. Each Party shall in good faith seek and use its Reasonable Efforts to obtain such other approvals. Nothing in this Agreement shall require Developer to take any action that could result in its inability to obtain, or its loss of, status or exemption under the Federal Power Act or the Public Utility Holding Company Act of 2005 or the Public Utility Regulatory Policies Act of 1978, as amended.

### 14.2 Governing Law.

**14.2.1** The validity, interpretation and performance of this Agreement and each of its provisions shall be governed by the laws of the state of New York, without regard to its conflicts of law principles.

**14.2.2** This Agreement is subject to all Applicable Laws and Regulations.

**14.2.3** Each Party expressly reserves the right to seek changes in, appeal, or otherwise contest any laws, orders, rules, or regulations of a Governmental Authority.

## ARTICLE 15. NOTICES

- 15.1 General.** Unless otherwise provided in this Agreement, any notice, demand or request required or permitted to be given by a Party to the other Parties and any instrument required or permitted to be tendered or delivered by a Party in writing to the other Parties shall be effective when delivered and may be so given, tendered or delivered, by recognized national courier, or by depositing the same with the United States Postal Service with postage prepaid, for delivery by certified or registered mail, addressed to the Party, or personally delivered to the Party, at the address set out in Appendix F hereto.

## SERVICE AGREEMENT NO. 1774

A Party may change the notice information in this Agreement by giving five (5) Business Days written notice prior to the effective date of the change.

- 15.2 Billings and Payments.** Billings and payments shall be sent to the addresses set out in Appendix F hereto.
- 15.3 Alternative Forms of Notice.** Any notice or request required or permitted to be given by a Party to the other Parties and not required by this Agreement to be given in writing may be so given by telephone, facsimile or email to the telephone numbers and email addresses set out in Appendix F hereto.
- 15.4 Operations and Maintenance Notice.** Developer and Connecting Transmission Owner shall each notify the other Party, and NYISO, in writing of the identity of the person(s) that it designates as the point(s) of contact with respect to the implementation of Articles 9 and 10 of this Agreement.

## ARTICLE 16. FORCE MAJEURE

### 16.1 Force Majeure.

16.1.1 Economic hardship is not considered a Force Majeure event.

16.1.2 A Party shall not be responsible or liable, or deemed, in Default with respect to any obligation hereunder, (including obligations under Article 4 of this Agreement) , other than the obligation to pay money when due, to the extent the Party is prevented from fulfilling such obligation by Force Majeure. A Party unable to fulfill any obligation hereunder (other than an obligation to pay money when due) by reason of Force Majeure shall give notice and the full particulars of such Force Majeure to the other Parties in writing or by telephone as soon as reasonably possible after the occurrence of the cause relied upon. Telephone notices given pursuant to this Article shall be confirmed in writing as soon as reasonably possible and shall specifically state full particulars of the Force Majeure, the time and date when the Force Majeure occurred and when the Force Majeure is reasonably expected to cease. The Party affected shall exercise due diligence to remove such disability with reasonable dispatch, but shall not be required to accede or agree to any provision not satisfactory to it in order to settle and terminate a strike or other labor disturbance.

**ARTICLE 17. DEFAULT**

**17.1 Default.**

**17.1.1 General.** No Breach shall exist where such failure to discharge an obligation (other than the payment of money) is the result of Force Majeure as defined in this Agreement or the result of an act or omission of the other Parties. Upon a Breach, the non-Breaching Parties shall give written notice of such to the Breaching Party. The Breaching Party shall have thirty (30) Calendar Days from receipt of the Breach notice within which to cure such Breach; provided however, if such Breach is not capable of cure within thirty (30) Calendar Days, the Breaching Party shall commence such cure within thirty (30) Calendar Days after notice and continuously and diligently complete such cure within ninety (90) Calendar Days from receipt of the Breach notice; and, if cured within such time, the Breach specified in such notice shall cease to exist.

**17.1.2 Right to Terminate.** If a Breach is not cured as provided in this Article 17, or if a Breach is not capable of being cured within the period provided for herein, the non-Breaching Parties acting together shall thereafter have the right to declare a Default and terminate this Agreement by written notice at any time until cure occurs, and be relieved of any further obligation hereunder and, whether or not those Parties terminate this Agreement, to recover from the defaulting Party all amounts due hereunder, plus all other damages and remedies to which they are entitled at law or in equity. The provisions of this Article will survive termination of this Agreement.

**ARTICLE 18. INDEMNITY, CONSEQUENTIAL DAMAGES AND INSURANCE**

**18.1 Indemnity.** Each Party (the “Indemnifying Party”) shall at all times indemnify, defend, and save harmless, as applicable, the other Parties (each an “Indemnified Party”) from, any and all damages, losses, claims, including claims and actions relating to injury to or death of any person or damage to property, the alleged violation of any Environmental Law, or the release or threatened release of any Hazardous Substance, demand, suits, recoveries, costs and expenses, court costs, attorney fees, and all other obligations by or to third parties, arising out of or resulting from (i) the Indemnified Party’s performance of its obligations under this Agreement on behalf of the Indemnifying Party, except in cases where the Indemnifying Party can demonstrate that the Loss of the Indemnified Party was caused by the gross negligence or intentional wrongdoing of the Indemnified Party or (ii) the violation by the Indemnifying Party of any Environmental Law or the release by the Indemnifying Party of any Hazardous Substance.

**18.1.1 Indemnified Party.** If a Party is entitled to indemnification under this Article 18 as a result of a claim by a third party, and the indemnifying Party fails, after notice and reasonable opportunity to proceed under Article 18.1.3, to assume the defense of such claim, such Indemnified Party may at the expense of the Indemnifying Party contest, settle or consent to the entry of any judgment with respect to, or pay in full, such claim.

**18.1.2 Indemnifying Party.** If an Indemnifying Party is obligated to indemnify and hold any Indemnified Party harmless under this Article 18, the amount owing to the Indemnified Party shall be the amount of such Indemnified Party's actual Loss, net of any insurance or other recovery.

**18.1.3 Indemnity Procedures.** Promptly after receipt by an Indemnified Party of any claim or notice of the commencement of any action or administrative or legal proceeding or investigation as to which the indemnity provided for in Article 18.1 may apply, the Indemnified Party shall notify the Indemnifying Party of such fact. Any failure of or delay in such notification shall not affect a Party's indemnification obligation unless such failure or delay is materially prejudicial to the Indemnifying Party.

Except as stated below, the Indemnifying Party shall have the right to assume the defense thereof with counsel designated by such Indemnifying Party and reasonably satisfactory to the Indemnified Party. If the defendants in any such action include one or more Indemnified Parties and the Indemnifying Party and if the Indemnified Party reasonably concludes that there may be legal defenses available to it and/or other Indemnified Parties which are different from or additional to those available to the Indemnifying Party, the Indemnified Party shall have the right to select separate counsel to assert such legal defenses and to otherwise participate in the defense of such action on its own behalf. In such instances, the Indemnifying Party shall only be required to pay the fees and expenses of one additional attorney to represent an Indemnified Party or Indemnified Parties having such differing or additional legal defenses.

The Indemnified Party shall be entitled, at its expense, to participate in any such action, suit or proceeding, the defense of which has been assumed by the Indemnifying Party. Notwithstanding the foregoing, the Indemnifying Party (i) shall not be entitled to assume and control the defense of any such action, suit or proceedings if and to the extent that, in the opinion of the Indemnified Party and its counsel, such action, suit or proceeding involves the potential imposition of criminal liability on the Indemnified Party, or there exists a conflict or adversity of interest between the Indemnified Party and the Indemnifying Party, in such event the Indemnifying Party shall pay the reasonable expenses of the Indemnified

## SERVICE AGREEMENT NO. 1774

Party, and (ii) shall not settle or consent to the entry of any judgment in any action, suit or proceeding without the consent of the Indemnified Party, which shall not be unreasonably withheld, conditioned or delayed.

**18.2 No Consequential Damages.** Other than the Liquidated Damages heretofore described and the indemnity obligations set forth in Article 18.1, in no event shall any Party be liable under any provision of this Agreement for any losses, damages, costs or expenses for any special, indirect, incidental, consequential, or punitive damages, including but not limited to loss of profit or revenue, loss of the use of equipment, cost of capital, cost of temporary equipment or services, whether based in whole or in part in contract, in tort, including negligence, strict liability, or any other theory of liability; provided, however, that damages for which a Party may be liable to another Party under separate agreement will not be considered to be special, indirect, incidental, or consequential damages hereunder.

**18.3 Insurance.** Developer and Connecting Transmission Owner shall each, at its own expense, maintain in force throughout the period of this Agreement, and until released by the other Parties, the following minimum insurance coverages, with insurers authorized to do business in the state of New York:

**18.3.1 Employers' Liability and Workers' Compensation Insurance** providing statutory benefits in accordance with the laws and regulations of New York State.

**18.3.2 Commercial General Liability Insurance** including premises and operations, personal injury, broad form property damage, broad form blanket contractual liability coverage (including coverage for the contractual indemnification) products and completed operations coverage, coverage for explosion, collapse and underground hazards, independent contractors coverage, coverage for pollution to the extent normally available and punitive damages to the extent normally available and a cross liability endorsement, with minimum limits of One Million Dollars (\$1,000,000) per occurrence/One Million Dollars (\$1,000,000) aggregate combined single limit for personal injury, bodily injury, including death and property damage.

**18.3.3 Comprehensive Automobile Liability Insurance** for coverage of owned and non-owned and hired vehicles, trailers or semi-trailers designed for travel on public roads, with a minimum, combined single limit of One Million Dollars (\$1,000,000) per occurrence for bodily injury, including death, and property damage.

## **SERVICE AGREEMENT NO. 1774**

- 18.3.4** Excess Public Liability Insurance over and above the Employers' Liability Commercial General Liability and Comprehensive Automobile Liability Insurance coverage, with a minimum combined single limit of Twenty Million Dollars (\$20,000,000) per occurrence/Twenty Million Dollars (\$20,000,000) aggregate.
- 18.3.5** The Commercial General Liability Insurance, Comprehensive Automobile Insurance and Excess Public Liability Insurance policies of Developer and Connecting Transmission Owner shall name the other Party, its parent, associated and Affiliate companies and their respective directors, officers, agents, servants and employees ("Other Party Group") as additional insured. All policies shall contain provisions whereby the insurers waive all rights of subrogation in accordance with the provisions of this Agreement against the Other Party Group and provide thirty (30) Calendar days advance written notice to the Other Party Group prior to anniversary date of cancellation or any material change in coverage or condition.
- 18.3.6** The Commercial General Liability Insurance, Comprehensive Automobile Liability Insurance and Excess Public Liability Insurance policies shall contain provisions that specify that the policies are primary and shall apply to such extent without consideration for other policies separately carried and shall state that each insured is provided coverage as though a separate policy had been issued to each, except the insurer's liability shall not be increased beyond the amount for which the insurer would have been liable had only one insured been covered. Developer and Connecting Transmission Owner shall each be responsible for its respective deductibles or retentions.
- 18.3.7** The Commercial General Liability Insurance, Comprehensive Automobile Liability Insurance and Excess Public Liability Insurance policies, if written on a Claims First Made Basis, shall be maintained in full force and effect for two (2) years after termination of this Agreement, which coverage may be in the form of tail coverage or extended reporting period coverage if agreed by the Developer and Connecting Transmission Owner.
- 18.3.8** The requirements contained herein as to the types and limits of all insurance to be maintained by the Developer and Connecting Transmission Owner are not intended to and shall not in any manner, limit or qualify the liabilities and obligations assumed by those Parties under this Agreement.
- 18.3.9** Within ten (10) days following execution of this Agreement, and as soon as practicable after the end of each fiscal year or at the renewal of the

## SERVICE AGREEMENT NO. 1774

insurance policy and in any event within ninety (90) days thereafter, Developer and Connecting Transmission Owner shall provide certification of all insurance required in this Agreement, executed by each insurer or by an authorized representative of each insurer.

**18.3.10** Notwithstanding the foregoing, Developer and Connecting Transmission Owner may each self-insure to meet the minimum insurance requirements of Articles 18.3.2 through 18.3.8 to the extent it maintains a self-insurance program; provided that, such Party's senior debt is rated at investment grade, or better, by Standard & Poor's and that its self-insurance program meets the minimum insurance requirements of Articles 18.3.2 through 18.3.8. For any period of time that a Party's senior debt is unrated by Standard & Poor's or is rated at less than investment grade by Standard & Poor's, such Party shall comply with the insurance requirements applicable to it under Articles 18.3.2 through 18.3.9. In the event that a Party is permitted to self-insure pursuant to this Article 18.3.10, it shall notify the other Party that it meets the requirements to self-insure and that its self-insurance program meets the minimum insurance requirements in a manner consistent with that specified in Article 18.3.9.

**18.3.11** Developer and Connecting Transmission Owner agree to report to each other in writing as soon as practical all accidents or occurrences resulting in injuries to any person, including death, and any property damage arising out of this Agreement.

## ARTICLE 19. ASSIGNMENT

**19.1 Assignment.** This Agreement may be assigned by a Party only with the written consent of the other Parties; provided that a Party may assign this Agreement without the consent of the other Parties to any Affiliate of the assigning Party with an equal or greater credit rating and with the legal authority and operational ability to satisfy the obligations of the assigning Party under this Agreement; provided further that a Party may assign this Agreement without the consent of the other Parties in connection with the sale, merger, restructuring, or transfer of a substantial portion or all of its assets, including the Attachment Facilities it owns, so long as the assignee in such a transaction directly assumes in writing all rights, duties and obligations arising under this Agreement; and provided further that the Developer shall have the right to assign this Agreement, without the consent of the NYISO or Connecting Transmission Owner, for collateral security purposes to aid in providing financing for the Large Generating Facility, provided that the Developer will promptly notify the NYISO and Connecting Transmission Owner of any such assignment. Any financing arrangement entered into by the Developer pursuant to this Article will provide that prior to or upon the exercise of the secured party's, trustee's

## SERVICE AGREEMENT NO. 1774

or mortgagee's assignment rights pursuant to said arrangement, the secured creditor, the trustee or mortgagee will notify the NYISO and Connecting Transmission Owner of the date and particulars of any such exercise of assignment right(s) and will provide the NYISO and Connecting Transmission Owner with proof that it meets the requirements of Articles 11.5 and 18.3. Any attempted assignment that violates this Article is void and ineffective. Any assignment under this Agreement shall not relieve a Party of its obligations, nor shall a Party's obligations be enlarged, in whole or in part, by reason thereof. Where required, consent to assignment will not be unreasonably withheld, conditioned or delayed.

### ARTICLE 20. SEVERABILITY

**20.1 Severability.** If any provision in this Agreement is finally determined to be invalid, void or unenforceable by any court or other Governmental Authority having jurisdiction, such determination shall not invalidate, void or make unenforceable any other provision, agreement or covenant of this Agreement; provided that if the Developer (or any third party, but only if such third party is not acting at the direction of the Connecting Transmission Owner) seeks and obtains such a final determination with respect to any provision of the Alternate Option (Article 5.1.2), or the Negotiated Option (Article 5.1.4), then none of these provisions shall thereafter have any force or effect and the rights and obligations of Developer and Connecting Transmission Owner shall be governed solely by the Standard Option (Article 5.1.1).

### ARTICLE 21. COMPARABILITY

**21.1 Comparability.** The Parties will comply with all applicable comparability and code of conduct laws, rules and regulations, as amended from time to time.

### ARTICLE 22. CONFIDENTIALITY

**22.1 Confidentiality.** Certain information exchanged by the Parties during the term of this Agreement shall constitute confidential information ("Confidential Information") and shall be subject to this Article 22.

If requested by a Party receiving information, the Party supplying the information shall provide in writing, the basis for asserting that the information referred to in this Article warrants confidential treatment, and the requesting Party may disclose such writing to the appropriate Governmental Authority. Each Party shall be responsible for the costs associated with affording confidential treatment to its information.

**22.1.1 Term.** During the term of this Agreement, and for a period of three (3) years after the expiration or termination of this Agreement, except as otherwise provided in this Article 22, each Party shall hold in confidence and shall not disclose to any person Confidential Information.

**22.1.2 Confidential Information.** The following shall constitute Confidential Information: (1) any non-public information that is treated as confidential by the disclosing Party and which the disclosing Party identifies as Confidential Information in writing at the time, or promptly after the time, of disclosure; or (2) information designated as Confidential Information by the NYISO Code of Conduct contained in Attachment F to the NYISO OATT.

**22.1.3 Scope.** Confidential Information shall not include information that the receiving Party can demonstrate: (1) is generally available to the public other than as a result of a disclosure by the receiving Party; (2) was in the lawful possession of the receiving Party on a non-confidential basis before receiving it from the disclosing Party; (3) was supplied to the receiving Party without restriction by a third party, who, to the knowledge of the receiving Party after due inquiry, was under no obligation to the disclosing Party to keep such information confidential; (4) was independently developed by the receiving Party without reference to Confidential Information of the disclosing Party; (5) is, or becomes, publicly known, through no wrongful act or omission of the receiving Party or Breach of this Agreement; or (6) is required, in accordance with Article 22.1.8 of this Agreement, Order of Disclosure, to be disclosed by any Governmental Authority or is otherwise required to be disclosed by law or subpoena, or is necessary in any legal proceeding establishing rights and obligations under this Agreement. Information designated as Confidential Information will no longer be deemed confidential if the Party that designated the information as confidential notifies the other Party that it no longer is confidential.

**22.1.4 Release of Confidential Information.** No Party shall release or disclose Confidential Information to any other person, except to its Affiliates (limited by FERC Standards of Conduct requirements), subcontractors, employees, consultants, or to parties who may be considering providing financing to or equity participation with Developer, or to potential purchasers or assignees of a Party, on a need-to-know basis in connection with this Agreement, unless such person has first been advised of the confidentiality provisions of this Article 22 and has agreed to comply with such provisions. Notwithstanding the foregoing, a Party providing Confidential Information to any person shall remain primarily responsible for any release of Confidential Information in contravention of this Article 22.

## SERVICE AGREEMENT NO. 1774

- 22.1.5 Rights.** Each Party retains all rights, title, and interest in the Confidential Information that each Party discloses to the other Party. The disclosure by each Party to the other Parties of Confidential Information shall not be deemed a waiver by any Party or any other person or entity of the right to protect the Confidential Information from public disclosure.
- 22.1.6 No Warranties.** By providing Confidential Information, no Party makes any warranties or representations as to its accuracy or completeness. In addition, by supplying Confidential Information, no Party obligates itself to provide any particular information or Confidential Information to the other Parties nor to enter into any further agreements or proceed with any other relationship or joint venture.
- 22.1.7 Standard of Care.** Each Party shall use at least the same standard of care to protect Confidential Information it receives as it uses to protect its own Confidential Information from unauthorized disclosure, publication or dissemination. Each Party may use Confidential Information solely to fulfill its obligations to the other Party under this Agreement or its regulatory requirements, including the NYISO OATT and NYISO Services Tariff. The NYISO shall, in all cases, treat the information it receives in accordance with the requirements of Attachment F to the NYISO OATT.
- 22.1.8 Order of Disclosure.** If a court or a Government Authority or entity with the right, power, and apparent authority to do so requests or requires any Party, by subpoena, oral deposition, interrogatories, requests for production of documents, administrative order, or otherwise, to disclose Confidential Information, that Party shall provide the other Parties with prompt notice of such request(s) or requirement(s) so that the other Parties may seek an appropriate protective order or waive compliance with the terms of this Agreement. Notwithstanding the absence of a protective order or waiver, the Party may disclose such Confidential Information which, in the opinion of its counsel, the Party is legally compelled to disclose. Each Party will use Reasonable Efforts to obtain reliable assurance that confidential treatment will be accorded any Confidential Information so furnished.
- 22.1.9 Termination of Agreement.** Upon termination of this Agreement for any reason, each Party shall, within ten (10) Calendar Days of receipt of a written request from the other Parties, use Reasonable Efforts to destroy, erase, or delete (with such destruction, erasure, and deletion certified in writing to the other Parties) or return to the other Parties, without

retaining copies thereof, any and all written or electronic Confidential Information received from the other Parties pursuant to this Agreement.

**22.1.10 Remedies.** The Parties agree that monetary damages would be inadequate to compensate a Party for another Party's Breach of its obligations under this Article 22. Each Party accordingly agrees that the other Parties shall be entitled to equitable relief, by way of injunction or otherwise, if the first Party Breaches or threatens to Breach its obligations under this Article 22, which equitable relief shall be granted without bond or proof of damages, and the receiving Party shall not plead in defense that there would be an adequate remedy at law. Such remedy shall not be deemed an exclusive remedy for the Breach of this Article 22, but shall be in addition to all other remedies available at law or in equity. The Parties further acknowledge and agree that the covenants contained herein are necessary for the protection of legitimate business interests and are reasonable in scope. No Party, however, shall be liable for indirect, incidental, or consequential or punitive damages of any nature or kind resulting from or arising in connection with this Article 22.

**22.1.11 Disclosure to FERC, its Staff, or a State.** Notwithstanding anything in this Article 22 to the contrary, and pursuant to 18 C.F.R. section 1b.20, if FERC or its staff, during the course of an investigation or otherwise, requests information from one of the Parties that is otherwise required to be maintained in confidence pursuant to this Agreement or the NYISO OATT, the Party shall provide the requested information to FERC or its staff, within the time provided for in the request for information. In providing the information to FERC or its staff, the Party must, consistent with 18 C.F.R. section 388.112, request that the information be treated as confidential and non-public by FERC and its staff and that the information be withheld from public disclosure. Parties are prohibited from notifying the other Parties to this Agreement prior to the release of the Confidential Information to the Commission or its staff. The Party shall notify the other Parties to the Agreement when it is notified by FERC or its staff that a request to release Confidential Information has been received by FERC, at which time the Parties may respond before such information would be made public, pursuant to 18 C.F.R. section 388.112. Requests from a state regulatory body conducting a confidential investigation shall be treated in a similar manner if consistent with the applicable state rules and regulations. A Party shall not be liable for any losses, consequential or otherwise, resulting from that Party divulging Confidential Information pursuant to a FERC or state regulatory body request under this paragraph.

## SERVICE AGREEMENT NO. 1774

**22.1.12** Except as otherwise expressly provided herein, no Party shall disclose Confidential Information to any person not employed or retained by the Party possessing the Confidential Information, except to the extent disclosure is (i) required by law; (ii) reasonably deemed by the disclosing Party to be required to be disclosed in connection with a dispute between or among the Parties, or the defense of litigation or dispute; (iii) otherwise permitted by consent of the other Party, such consent not to be unreasonably withheld; or (iv) necessary to fulfill its obligations under this Agreement, the NYISO OATT or the NYISO Services Tariff. Prior to any disclosures of a Party's Confidential Information under this subparagraph, or if any third party or Governmental Authority makes any request or demand for any of the information described in this subparagraph, the disclosing Party agrees to promptly notify the other Party in writing and agrees to assert confidentiality and cooperate with the other Party in seeking to protect the Confidential Information from public disclosure by confidentiality agreement, protective order or other reasonable measures.

### ARTICLE 23. ENVIRONMENTAL RELEASES

**23.1 Developer and Connecting Transmission Owner Notice.** Developer and Connecting Transmission Owner shall each notify the other Party, first orally and then in writing, of the release of any Hazardous Substances, any asbestos or lead abatement activities, or any type of remediation activities related to the Large Generating Facility or the Attachment Facilities, each of which may reasonably be expected to affect the other Party. The notifying Party shall: (i) provide the notice as soon as practicable, provided such Party makes a good faith effort to provide the notice no later than twenty-four hours after such Party becomes aware of the occurrence; and (ii) promptly furnish to the other Party copies of any publicly available reports filed with any Governmental Authorities addressing such events.

### ARTICLE 24. INFORMATION REQUIREMENT

**24.1 Information Acquisition.** Connecting Transmission Owner and Developer shall each submit specific information regarding the electrical characteristics of their respective facilities to the other, and to NYISO, as described below and in accordance with Applicable Reliability Standards.

**24.2 Information Submission by Connecting Transmission Owner.** The initial information submission by Connecting Transmission Owner shall occur no later than one hundred eighty (180) Calendar Days prior to Trial Operation and shall include New York State Transmission System information necessary to allow the Developer to select equipment and meet any system protection and stability requirements, unless otherwise mutually agreed to by the Developer and Connecting Transmission Owner. On a monthly basis Connecting Transmission Owner shall provide Developer and NYISO a status report on

## SERVICE AGREEMENT NO. 1774

the construction and installation of Connecting Transmission Owner's Attachment Facilities and System Upgrade Facilities and System Deliverability Upgrades, including, but not limited to, the following information: (1) progress to date; (2) a description of the activities since the last report; (3) a description of the action items for the next period; and (4) the delivery status of equipment ordered.

- 24.3 Updated Information Submission by Developer.** The updated information submission by the Developer, including manufacturer information, shall occur no later than one hundred eighty (180) Calendar Days prior to the Trial Operation. Developer shall submit a completed copy of the Large Generating Facility data requirements contained in Appendix 1 to the Large Facility Interconnection Procedures. It shall also include any additional information provided to Connecting Transmission Owner for the Interconnection Feasibility Study and Interconnection Facilities Study. Information in this submission shall be the most current Large Generating Facility design or expected performance data. Information submitted for stability models shall be compatible with NYISO standard models. If there is no compatible model, the Developer will work with a consultant mutually agreed to by the Parties to develop and supply a standard model and associated information.

If the Developer's data is different from what was originally provided to Connecting Transmission Owner and NYISO pursuant to an Interconnection Study Agreement among Connecting Transmission Owner, NYISO and Developer and this difference may be reasonably expected to affect the other Parties' facilities or the New York State Transmission System, but does not require the submission of a new Interconnection Request, then NYISO will conduct appropriate studies to determine the impact on the New York State Transmission System based on the actual data submitted pursuant to this Article 24.3. Such studies will provide an estimate of any additional modifications to the New York State Transmission System, Connecting Transmission Owner's Attachment Facilities, or System Upgrade Facilities or System Deliverability Upgrades based on the actual data and a good faith estimate of the costs thereof. The Developer shall not begin Trial Operation until such studies are completed. The Developer shall be responsible for the cost of any modifications required by the actual data, including the cost of any required studies.

- 24.4 Information Supplementation.** Prior to the Commercial Operation Date, the Developer and Connecting Transmission Owner shall supplement their information submissions described above in this Article 24 with any and all "as-built" Large Generating Facility information or "as-tested" performance information that differs from the initial submissions or, alternatively, written confirmation that no such differences exist. The Developer shall conduct tests on the Large Generating Facility as required by Good Utility Practice such as an open circuit "step voltage" test on the Large Generating Facility to verify proper operation of the Large Generating Facility's automatic voltage regulator.

## SERVICE AGREEMENT NO. 1774

Unless otherwise agreed, the test conditions shall include: (1) Large Generating Facility at synchronous speed; (2) automatic voltage regulator on and in voltage control mode; and (3) a five percent change in Large Generating Facility terminal voltage initiated by a change in the voltage regulators reference voltage. Developer shall provide validated test recordings showing the responses of Large Generating Facility terminal and field voltages. In the event that direct recordings of these voltages is impractical, recordings of other voltages or currents that mirror the response of the Large Generating Facility's terminal or field voltage are acceptable if information necessary to translate these alternate quantities to actual Large Generating Facility terminal or field voltages is provided. Large Generating Facility testing shall be conducted and results provided to the Connecting Transmission Owner and NYISO for each individual generating unit in a station.

Subsequent to the Commercial Operation Date, the Developer shall provide Connecting Transmission Owner and NYISO any information changes due to equipment replacement, repair, or adjustment. Connecting Transmission Owner shall provide the Developer and NYISO any information changes due to equipment replacement, repair or adjustment in the directly connected substation or any adjacent Connecting Transmission Owner substation that may affect the Developer Attachment Facilities equipment ratings, protection or operating requirements. The Developer and Connecting Transmission Owner shall provide such information no later than thirty (30) Calendar Days after the date of the equipment replacement, repair or adjustment.

### ARTICLE 25. INFORMATION ACCESS AND AUDIT RIGHTS

- 25.1 Information Access.** Each Party ("Disclosing Party") shall make available to another Party ("Requesting Party") information that is in the possession of the Disclosing Party and is necessary in order for the Requesting Party to: (i) verify the costs incurred by the Disclosing Party for which the Requesting Party is responsible under this Agreement; and (ii) carry out its obligations and responsibilities under this Agreement. The Parties shall not use such information for purposes other than those set forth in this Article 25.1 of this Agreement and to enforce their rights under this Agreement.
- 25.2 Reporting of Non-Force Majeure Events.** Each Party (the "Notifying Party") shall notify the other Parties when the Notifying Party becomes aware of its inability to comply with the provisions of this Agreement for a reason other than a Force Majeure event. The Parties agree to cooperate with each other and provide necessary information regarding such inability to comply, including the date, duration, reason for the inability to comply, and corrective actions taken or planned to be taken with respect to such inability to comply. Notwithstanding the foregoing, notification, cooperation or information provided under this Article shall not entitle the Party receiving such notification to allege a cause for anticipatory breach of this Agreement.
- 25.3 Audit Rights.** Subject to the requirements of confidentiality under Article 22 of this Agreement, each Party shall have the right, during normal business hours, and upon prior

## SERVICE AGREEMENT NO. 1774

reasonable notice to another Party, to audit at its own expense the other Party's accounts and records pertaining to the other Party's performance or satisfaction of its obligations under this Agreement. Such audit rights shall include audits of the other Party's costs, calculation of invoiced amounts, and each Party's actions in an Emergency State. Any audit authorized by this Article shall be performed at the offices where such accounts and records are maintained and shall be limited to those portions of such accounts and records that relate to the Party's performance and satisfaction of obligations under this Agreement. Each Party shall keep such accounts and records for a period equivalent to the audit rights periods described in Article 25.4 of this Agreement.

### **25.4 Audit Rights Periods.**

#### **25.4.1 Audit Rights Period for Construction-Related Accounts and Records.**

Accounts and records related to the design, engineering, procurement, and construction of Connecting Transmission Owner's Attachment Facilities and System Upgrade Facilities and System Deliverability Upgrades shall be subject to audit for a period of twenty-four months following Connecting Transmission Owner's issuance of a final invoice in accordance with Article 12.2 of this Agreement.

**25.4.2 Audit Rights Period for All Other Accounts and Records.** Accounts and records related to a Party's performance or satisfaction of its obligations under this Agreement other than those described in Article 25.4.1 of this Agreement shall be subject to audit as follows: (i) for an audit relating to cost obligations, the applicable audit rights period shall be twenty-four months after the auditing Party's receipt of an invoice giving rise to such cost obligations; and (ii) for an audit relating to all other obligations, the applicable audit rights period shall be twenty-four months after the event for which the audit is sought.

**25.5 Audit Results.** If an audit by a Party determines that an overpayment or an underpayment has occurred, a notice of such overpayment or underpayment shall be given to the other Party together with those records from the audit which support such determination.

## **ARTICLE 26. SUBCONTRACTORS**

**26.1 General.** Nothing in this Agreement shall prevent a Party from utilizing the services of any subcontractor as it deems appropriate to perform its obligations under this Agreement; provided, however, that each Party shall require its subcontractors to comply with all applicable terms and conditions of this Agreement in providing such services and each Party shall remain primarily liable to the other Parties for the performance of such subcontractor.

## SERVICE AGREEMENT NO. 1774

- 26.2 Responsibility of Principal.** The creation of any subcontract relationship shall not relieve the hiring Party of any of its obligations under this Agreement. The hiring Party shall be fully responsible to the other Parties for the acts or omissions of any subcontractor the hiring Party hires as if no subcontract had been made; provided, however, that in no event shall the NYISO or Connecting Transmission Owner be liable for the actions or inactions of the Developer or its subcontractors with respect to obligations of the Developer under Article 5 of this Agreement. Any applicable obligation imposed by this Agreement upon the hiring Party shall be equally binding upon, and shall be construed as having application to, any subcontractor of such Party.
- 26.3 No Limitation by Insurance.** The obligations under this Article 26 will not be limited in any way by any limitation of subcontractor's insurance.

### ARTICLE 27. DISPUTES

- 27.1 Submission.** In the event any Party has a dispute, or asserts a claim, that arises out of or in connection with this Agreement or its performance (a "Dispute"), such Party shall provide the other Parties with written notice of the Dispute ("Notice of Dispute"). Such Dispute shall be referred to a designated senior representative of each Party for resolution on an informal basis as promptly as practicable after receipt of the Notice of Dispute by the other Parties. In the event the designated representatives are unable to resolve the Dispute through unassisted or assisted negotiations within thirty (30) Calendar Days of the other Parties' receipt of the Notice of Dispute, such Dispute may, upon mutual agreement of the Parties, be submitted to arbitration and resolved in accordance with the arbitration procedures set forth below. In the event the Parties do not agree to submit such Dispute to arbitration, each Party may exercise whatever rights and remedies it may have in equity or at law consistent with the terms of this Agreement.
- 27.2 External Arbitration Procedures.** Any arbitration initiated under this Agreement shall be conducted before a single neutral arbitrator appointed by the Parties. If the Parties fail to agree upon a single arbitrator within ten (10) Calendar Days of the submission of the Dispute to arbitration, each Party shall choose one arbitrator who shall sit on a three-member arbitration panel. In each case, the arbitrator(s) shall be knowledgeable in electric utility matters, including electric transmission and bulk power issues, and shall not have any current or past substantial business or financial relationships with any party to the arbitration (except prior arbitration). The arbitrator(s) shall provide each of the Parties an opportunity to be heard and, except as otherwise provided herein, shall conduct the arbitration in accordance with the Commercial Arbitration Rules of the American Arbitration Association ("Arbitration Rules") and any applicable FERC regulations or RTO rules; provided, however, in the event of a conflict between the Arbitration Rules and the terms of this Article 27, the terms of this Article 27 shall prevail.
- 27.3 Arbitration Decisions.** Unless otherwise agreed by the Parties, the arbitrator(s) shall render a decision within ninety (90) Calendar Days of appointment and shall notify the Parties in writing of such decision and the reasons therefor. The arbitrator(s) shall be

## SERVICE AGREEMENT NO. 1774

authorized only to interpret and apply the provisions of this Agreement and shall have no power to modify or change any provision of this Agreement in any manner. The decision of the arbitrator(s) shall be final and binding upon the Parties, and judgment on the award may be entered in any court having jurisdiction. The decision of the arbitrator(s) may be appealed solely on the grounds that the conduct of the arbitrator(s), or the decision itself, violated the standards set forth in the Federal Arbitration Act or the Administrative Dispute Resolution Act. The final decision of the arbitrator must also be filed with FERC if it affects jurisdictional rates, terms and conditions of service, Attachment Facilities, or System Upgrade Facilities, or System Deliverability Upgrades.

- 27.4 Costs.** Each Party shall be responsible for its own costs incurred during the arbitration process and for the following costs, if applicable: (1) the cost of the arbitrator chosen by the Party to sit on the three member panel; or (2) one-third the cost of the single arbitrator jointly chosen by the Parties.
- 27.5 Termination.** Notwithstanding the provisions of this Article 27, any Party may terminate this Agreement in accordance with its provisions or pursuant to an action at law or equity. The issue of whether such a termination is proper shall not be considered a Dispute hereunder.

### ARTICLE 28. REPRESENTATIONS, WARRANTIES AND COVENANTS

- 28.1 General.** Each Party makes the following representations, warranties and covenants:

**28.1.1 Good Standing.** Such Party is duly organized, validly existing and in good standing under the laws of the state in which it is organized, formed, or incorporated, as applicable; that it is qualified to do business in the state or states in which the Large Generating Facility, Attachment Facilities and System Upgrade Facilities and System Deliverability Upgrades owned by such Party, as applicable, are located; and that it has the corporate power and authority to own its properties, to carry on its business as now being conducted and to enter into this Agreement and carry out the transactions contemplated hereby and perform and carry out all covenants and obligations on its part to be performed under and pursuant to this Agreement.

**28.1.2 Authority.** Such Party has the right, power and authority to enter into this Agreement, to become a Party hereto and to perform its obligations hereunder. This Agreement is a legal, valid and binding obligation of such Party, enforceable against such Party in accordance with its terms, except as the enforceability thereof may be limited by applicable bankruptcy, insolvency, reorganization or other similar laws affecting creditors' rights

## SERVICE AGREEMENT NO. 1774

generally and by general equitable principles (regardless of whether enforceability is sought in a proceeding in equity or at law).

**28.1.3 No Conflict.** The execution, delivery and performance of this Agreement does not violate or conflict with the organizational or formation documents, or bylaws or operating agreement, of such Party, or any judgment, license, permit, order, material agreement or instrument applicable to or binding upon such Party or any of its assets.

**28.1.4 Consent and Approval.** Such Party has sought or obtained, or, in accordance with this Agreement will seek or obtain, each consent, approval, authorization, order, or acceptance by any Governmental Authority in connection with the execution, delivery and performance of this Agreement, and it will provide to any Governmental Authority notice of any actions under this Agreement that are required by Applicable Laws and Regulations.

## ARTICLE 29. MISCELLANEOUS

**29.1 Binding Effect.** This Agreement and the rights and obligations hereof, shall be binding upon and shall inure to the benefit of the successors and permitted assigns of the Parties hereto.

**29.2 Conflicts.** If there is a discrepancy or conflict between or among the terms and conditions of this cover agreement and the Appendices hereto, the terms and conditions of this cover agreement shall be given precedence over the Appendices, except as otherwise expressly agreed to in writing by the Parties.

**29.3 Rules of Interpretation.** This Agreement, unless a clear contrary intention appears, shall be construed and interpreted as follows: (1) the singular number includes the plural number and vice versa; (2) reference to any person includes such person's successors and assigns but, in the case of a Party, only if such successors and assigns are permitted by this Agreement, and reference to a person in a particular capacity excludes such person in any other capacity or individually; (3) reference to any agreement (including this Agreement), document, instrument or tariff means such agreement, document, instrument, or tariff as amended or modified and in effect from time to time in accordance with the terms thereof and, if applicable, the terms hereof; (4) reference to any Applicable Laws and Regulations means such Applicable Laws and Regulations as amended, modified, codified, or reenacted, in whole or in part, and in effect from time to time, including, if applicable, rules and regulations promulgated thereunder; (5) unless expressly stated otherwise, reference to any Article, Section or Appendix means such Article of this Agreement or such Appendix to this Agreement, or such Section to the Large Facility Interconnection Procedures or such Appendix to the Large Facility

## SERVICE AGREEMENT NO. 1774

Interconnection Procedures, as the case may be; (6) “hereunder”, “hereof”, “herein”, “hereto” and words of similar import shall be deemed references to this Agreement as a whole and not to any particular Article or other provision hereof or thereof; (7) “including” (and with correlative meaning “include”) means including without limiting the generality of any description preceding such term; and (8) relative to the determination of any period of time, “from” means “from and including”, “to” means “to but excluding” and “through” means “through and including”.

- 29.4 Compliance.** Each Party shall perform its obligations under this Agreement in accordance with Applicable Laws and Regulations, Applicable Reliability Standards, the NYISO OATT and Good Utility Practice. To the extent a Party is required or prevented or limited in taking any action by such regulations and standards, such Party shall not be deemed to be in Breach of this Agreement for its compliance therewith. When any Party becomes aware of such a situation, it shall notify the other Parties promptly so that the Parties can discuss the amendment to this Agreement that is appropriate under the circumstances.
- 29.5 Joint and Several Obligations.** Except as otherwise stated herein, the obligations of NYISO, Developer and Connecting Transmission Owner are several, and are neither joint nor joint and several.
- 29.6 Entire Agreement.** This Agreement, including all Appendices and Schedules attached hereto, constitutes the entire agreement between the Parties with reference to the subject matter hereof, and supersedes all prior and contemporaneous understandings or agreements, oral or written, between the Parties with respect to the subject matter of this Agreement. There are no other agreements, representations, warranties, or covenants which constitute any part of the consideration for, or any condition to, either Party’s compliance with its obligations under this Agreement.
- 29.7 No Third Party Beneficiaries.** This Agreement is not intended to and does not create rights, remedies, or benefits of any character whatsoever in favor of any persons, corporations, associations, or entities other than the Parties, and the obligations herein assumed are solely for the use and benefit of the Parties, their successors in interest and permitted their assigns.
- 29.8 Waiver.** The failure of a Party to this Agreement to insist, on any occasion, upon strict performance of any provision of this Agreement will not be considered a waiver of any obligation, right, or duty of, or imposed upon, such Party. Any waiver at any time by either Party of its rights with respect to this Agreement shall not be deemed a continuing waiver or a waiver with respect to any other failure to comply with any other obligation, right, duty of this Agreement. Termination or Default of this Agreement for any reason by the Developer shall not constitute a waiver of the Developer’s legal rights to obtain Capacity Resource Interconnection Service and Energy Resource Interconnection Service from the NYISO and Connecting Transmission Owner in accordance with the provisions

## SERVICE AGREEMENT NO. 1774

of the NYISO OATT. Any waiver of this Agreement shall, if requested, be provided in writing.

- 29.9 Headings.** The descriptive headings of the various Articles of this Agreement have been inserted for convenience of reference only and are of no significance in the interpretation or construction of this Agreement.
- 29.10 Multiple Counterparts.** This Agreement may be executed in two or more counterparts, each of which is deemed an original but all constitute one and the same instrument.
- 29.11 Amendment.** The Parties may by mutual agreement amend this Agreement, by a written instrument duly executed by all three of the Parties.
- 29.12 Modification by the Parties.** The Parties may by mutual agreement amend the Appendices to this Agreement, by a written instrument duly executed by all three of the Parties. Such an amendment shall become effective and a part of this Agreement upon satisfaction of all Applicable Laws and Regulations.
- 29.13 Reservation of Rights.** NYISO and Connecting Transmission Owner shall have the right to make unilateral filings with FERC to modify this Agreement with respect to any rates, terms and conditions, charges, classifications of service, rule or regulation under section 205 or any other applicable provision of the Federal Power Act and FERC's rules and regulations thereunder, and Developer shall have the right to make a unilateral filing with FERC to modify this Agreement pursuant to section 206 or any other applicable provision of the Federal Power Act and FERC's rules and regulations thereunder; provided that each Party shall have the right to protest any such filing by another Party and to participate fully in any proceeding before FERC in which such modifications may be considered. Nothing in this Agreement shall limit the rights of the Parties or of FERC under sections 205 or 206 of the Federal Power Act and FERC's rules and regulations thereunder, except to the extent that the Parties otherwise mutually agree as provided herein.
- 29.14 No Partnership.** This Agreement shall not be interpreted or construed to create an association, joint venture, agency relationship, or partnership among the Parties or to impose any partnership obligation or partnership liability upon any Party. No Party shall have any right, power or authority to enter into any agreement or undertaking for, or act on behalf of, or to act as or be an agent or representative of, or to otherwise bind, any other Party.
- 29.15 Other Transmission Rights.** Notwithstanding any other provision of this Agreement, nothing herein shall be construed as relinquishing or foreclosing any rights, including but not limited to firm transmission rights, capacity rights, or transmission congestion rights that the Developer shall be entitled to, now or in the future under any other agreement or

**SERVICE AGREEMENT NO. 1774**

tariff as a result of, or otherwise associated with, the transmission capacity, if any, created by the System Upgrade Facilities and System Deliverability Upgrades.

**SERVICE AGREEMENT NO. 1774**

**IN WITNESS WHEREOF**, the Parties have executed this LGIA in duplicate originals, each of which shall constitute and be an original effective Agreement between the Parties.

**New York Independent System  
Operator, Inc.**

**New York Power Authority**

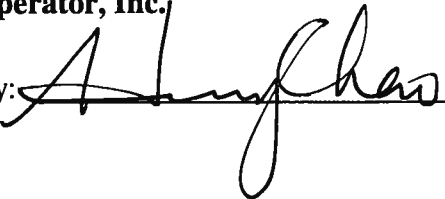
By:  \_\_\_\_\_

By: \_\_\_\_\_

Title: VP, System & Resource Planning \_\_\_\_\_

Title: \_\_\_\_\_

Date: June 13, 2012 \_\_\_\_\_

Date: \_\_\_\_\_

**Marble River, LLC**

By: \_\_\_\_\_

Title: \_\_\_\_\_

Date: \_\_\_\_\_

**SERVICE AGREEMENT NO. 1774**

**IN WITNESS WHEREOF**, the Parties have executed this LGIA in duplicate originals, each of which shall constitute and be an original effective Agreement between the Parties.

**New York Independent System  
Operator, Inc.**

**New York Power Authority**

By: \_\_\_\_\_

By: Edward A. Reid

Title: \_\_\_\_\_

Title: Vice President Transmission

Date: \_\_\_\_\_

Date: June 4, 2012

**Marble River, LLC**

By: \_\_\_\_\_

Title: \_\_\_\_\_

Date: \_\_\_\_\_

**SERVICE AGREEMENT NO. 1774**

**IN WITNESS WHEREOF**, the Parties have executed this LGIA in duplicate originals, each of which shall constitute and be an original effective Agreement between the Parties.

**New York Independent System  
Operator, Inc.**

**New York Power Authority**

By: \_\_\_\_\_

By: \_\_\_\_\_

Title: \_\_\_\_\_

Title: \_\_\_\_\_

Date: \_\_\_\_\_

Date: \_\_\_\_\_

**Marble River, LLC**

By: William Whitlock

By: Steve Irvin

William Whitlock  
Executive Vice President, Eastern Region

Steve Irvin  
Executive Vice President, Central Region

Title: EVP

Title: EVP

Date: JUNE 7, 2012

Date: 6/7/2012

*YMBL*

**SERVICE AGREEMENT NO. 1774**

**APPENDICES**

**Appendix A**

Attachment Facilities and System Upgrade Facilities

**Appendix B**

Milestones

**Appendix C**

Interconnection Details

**Appendix D**

Security Arrangements Details

**Appendix E**

Commercial Operation Date

**Appendix F**

Addresses for Delivery of Notices and Billings

**Appendix G**

Interconnection Requirements for a Wind Generating Plant

**Appendix H**

Invoicing and Payment

APPENDIX A

Attachment Facilities and System Upgrade Facilities

I. ATTACHMENT FACILITIES

(A) Developer's Attachment Facilities:

The Marble River Collection Substation is an outdoor air insulated low profile design, single bus configuration. It consists of one 230kV, 2000A three-phase switch, eight 34.5kV, 1200A, 40kA interrupting vacuum circuit breakers for the collection circuits. There is also one 4000A main breaker for connecting the 34.5kV collector bus to the 34.5/230kV step-up transformer. This particular breaker is an SF6 type, rated 121kV and 550kV BIL and 40kA interrupting capability. The voltage and BIL ratings are higher than typical 34.5kV installations due to required current carrying capacity. The substation circuit breakers, disconnect switches, PTs, CTs, and surge arresters are interconnected together by a combination of strain buses and rigid buses mounted on porcelain insulators, supported on steel structures.

The Marble River Collection Substation 34.5kV system includes circuit breaker current transformers and bus connected voltage transformer for metering and relaying. A dedicated 167 kVA 34.5kV/120-240V station service transformer will supply power for the station service to the Patnode 230kV Switchyard. A separate 34.5 kV/120-240 VAC 75 kVA transformer will supply the station service to the Marble River substation. All equipment, including fences, is grounded to a sub-grade grounding system designed to IEEE 80 requirements. The substation area, including three feet beyond the fence, shall be covered with six inches of stone. The stone shall consist of clean, angular fragments of rock, free from soft disintegrated pieces or objectionable matter. The Marble River Collection Substation is being built adjacent to the POI substation. The connection between the substation is a short 230 KV bus section with a final connection with bus jumpers to Marble River's 230 kV disconnect switches.

**The Main Step-up Transformer** is an outdoor mineral oil filled, forced air cooled, 34.5/230 kV three phase transformer, rated at 140/187/233 MVA. The transformer shall be connected grounded wye on the 34.5 kV side, and delta on the 230 kV side with a no-load tap changer. The transformer is equipped with surge arresters, current transformers and ANSI standard accessories.

**Station Service** – A 34.5kV/120-240V station service transformer will supply power for the station service to the Marble River Substation. The kVA size is 75 kVA. The alternate station service shall be provided via the local distribution.

**Foundations** – The Marble River Collection Substation contains 36 small to medium sized foundations for breakers, structures, etc., control house foundation and one foundation for the transformer including an oil containment pit.

**Control Building** – The Marble River Collection Substation control building shall be a pre-fabricated building complete and wired with HVAC equipment, switchboard panels, electrical and electronic equipment including lighting, receptacles, AC/DC panels, switches, overhead cable tray, conduits, grounding system, batteries, chargers, portable eyewash stations,

portable fire extinguishers, exit signs, emergency lighting, security system and minimal furniture.

**Protective Relaying – Main Step-up Transformer Protection:** The primary protective device is a high speed transformer current differential relay with backup phase and high-set instantaneous overcurrent protection. The secondary protective device provides high speed current differential and neutral overcurrent protection. Both the primary and secondary relays, which are Developer's Attachment Facilities, are located in the 230 kV Control Building, which is a Connecting Transmission Owner's Attachment Facility, described in Section II(A), Item A8 of this Appendix A. This transformer is equipped with sudden pressure protection, liquid low level protection, high oil/winding temperature protection, Buchholz gas accumulator, and high pressure relief.

**34.5kV Collector Lines Feeder Protection:** The protective device provides directional phase and ground overcurrent protection, including breaker failure protection. Breaker failure of each collector circuit breaker will initiate the lock out relay to trip and block close all 34.5kV breakers.

**34.5kV Collector Bus Protection:** The 34.5kV bus protection uses a bus differential relay and provides overall 34.5kV bus protection. Bus fault will initiate lockout relay to trip and block close all 34.5k breakers.

**SCADA - Supervisory Control and Data Acquisition (SCADA):** The SCADA system will provide full monitoring of the substation a 100Mbit TCP/IP network and broadband Internet connection with a VPN infrastructure. The associated equipment will be located within the Marble River Collection Substation control building.

**Disconnect Switches:**

- The 230 kV Disconnect Switch will be worm gear operated, 230 kV, three phase, vertical break, 900 kV BIL, 2000A, 60 Hz.
- The 34.5KV disconnect switch will be a group operated motor disconnect switch, 4000A, 3-phase, vertical break, 200KV BIL, 60 Hz
- There are a total of 48 switches for the eight 38kV (34.5kV nominal) breaker positions. Each 38 kV (34.5kV nominal) circuit breaker will have six, single phase, hook-stick disconnect switches rated 1200A, 38 kV. These switches are manually operated via a hot-stick by a substation operator.

**34.5 kV Feeder Breaker Information:** Eight (8) 34.5 kV vacuum breakers – three (3) cycle, 1200A, **40 kA interrupting capability**, with a high speed grounding switch).

**(B) Connecting Transmission Owner's Attachment Facilities:**

This Section I(B) describes the Connecting Transmission Owner's Attachment Facilities for the Marble River Large Generating Facility. The Connecting Transmission Owner's Attachment Facilities will be constructed by the Developer.

The Connecting Transmission Owner's Attachment Facilities (CTOAF) are the facilities between the Point of Interconnection and the Point of Change of Ownership as depicted on Figure 1 to this Appendix A. These facilities will include bus work, bus support, one three phase 230 kV disconnect switch, and one set of revenue metering CT/PT units. The Point of Interconnection will be at the new 230 kV Patnode Substation ring bus on the existing 230 kV NYPA WD-1 line, further described in Section II of this Appendix A.

The following is the identification and description of the equipment and construction work required to build the Connecting Transmission Owner's Attachment Facilities at the Patnode Substation.

- a. **Foundations:** Miscellaneous equipment foundations for the bus work, disconnect switch and CT/PT units were designed in accordance with generally accepted practices of soil mechanics and the design criteria for the Patnode Station.
- b. **Revenue Metering CT/PT:** The 230 kV Revenue Metering Instrument transformers will consist of one set of CT/PT combined units. The PT is provided with dual secondary windings. The turns ratio of the PT is 138,000V/115-69V for each of the secondary windings. The CT will be extended range, rated 500:5A, 0.15B1.8, RF.1.33.
- c. **Disconnect Switch:** The Disconnect Switch will be rated 242 kV, 2000A, 900 KVIL with an auxiliary switch attachment to indicate position status.
- d. **Transformer bay protection** will be provided by both high-speed differential protection and overcurrent protection. The primary and backup systems protect the portion of the 230 kV ring bus connected to the Developer's main step-up transformer as well as the main step-up transformer. The relays were selected by the Developer and approved by the Connecting Transmission Owner.

**(C) CTOAF Cost Estimates (See Section II B)**

**II. STAND ALONE SYSTEM UPGRADE FACILITIES ASSOCIATED WITH MARBLE RIVER LARGE GENERATING FACILITY**

Pursuant to Article 5.1.3 of this Interconnection Agreement, the Developer has chosen the option to build the Stand Alone System Upgrade Facilities ("SASUF"). The Developer will design, construct and pre-commission the Point of Interconnection switchyard ("Patnode Substation"). The Patnode Substation will contain the 230kV take off structures from the WD-1 line, aluminum bus work, three 230 kV circuit breakers, two motorized disconnect switches with ground switches, seven breaker disconnect switches, and a 230kV control house. In addition, a Microwave System at Patnode Substation will maintain communications with Connecting

## SERVICE AGREEMENT NO. 1774

Transmission Owner facilities in Ryan Station with equipment supplied and installed by Developer. The three 230kV circuit breakers are SF6 type, rated 245kV, 3000A, 63kA.

The Patnode Substation will be configured as a three breaker ring bus. The Willis Duley WD-1 230kV line will connect to the breaker equipped bay. The Developer's 233 MVA transformer will connect to the East Bus of the Patnode Substation. The transformer will be connected through a disconnect switch under the Connecting Transmission Owner's control and a high side transformer disconnect switch under the Developer's control (see Figure 1). The Patnode Substation will be located adjacent to the Connecting Transmission Owner's Transmission right of way on land that will be deeded to the Connecting Transmission Owner.

### (A) Patnode Substation:

The following describes the design, construction and commissioning requirements for the Patnode Substation. All work by Developer shall meet the NYPA Design Criteria for Developer Connection to the New York Power Authority Transmission System and NYPA's Project Management Criteria for Developer Connection to the New York Power Authority Transmission System, subject to the Exceptions and Clarifications to each such document agreed to by Developer and Connecting Transmission Owner.

- 1. Site Work** – The Developer shall be responsible for the clearing, grubbing and backfilling, with proper compaction, of the new Patnode Substation. The Developer shall design the site for proper drainage with a slope of one (1) percent. The site plan shall provide for good drainage with no accumulation of standing water.
- 2. Foundations** – Foundations will be designed in accordance with generally accepted practices of soil mechanics. All structure designs, calculations and drawings shall be provided to the Connecting Transmission Owner with certification by a New York State licensed Professional Engineer. The Developer shall provide the Connecting Transmission Owner with a rebar reinforcement and concrete mix design for approval, prior to placement of any concrete.
- 3. Site Access Road** -- The Developer shall be responsible for providing a Sub-Easement Agreement granting the Connecting Transmission Owner the rights to utilize the private access road to the Patnode Substation for the duration of this Interconnection Agreement. The Developer will be responsible for road repairs and maintenance, including snow removal.
- 4. Steel Structures** – The Patnode Substation shall consist of low profile (non-lattice) steel structures. The air-insulated substation shall be rigid bus construction with flexible connections to all equipment. Equipment support structures shall be designed by the working stress method in accordance with American Institute of Steel Construction guidelines for specification, engineering, design and construction.
- 5. Station Service** – A 34.5kV/120-240V station service transformer will supply power for the station service to the Patnode 230kV Switchyard (Connecting Transmission Owner's Attachment Facility and Patnode Substation)(see Figure 1). The kVA size is 167kVA. The alternate station service shall be provided via the local distribution utility and an

emergency generator rated 140 kW. Marble River Substation will have its own dedicated 75 kVA, 120/240 VAC station service transformer with an alternative service feed from the local distribution provider. The station service transformer shall be located at the Marble River Substation (as described in Figure 1). The Developer shall be solely responsible for the ownership, maintenance and operations of the station service transformer.

6. **Grounding** - A complete grounding system (above & below grade) is required for the Patnode Substation in accordance with the Connecting Transmission Owner's grounding standards. The grounding system shall be designed in accordance with IEEE Std. 80-2000, latest version. The complete ground system design, including all calculations and data, shall be reviewed and approved by a New York State Professional Engineer. The final ground design will be subject to the Connecting Transmission Owner's review and acceptance. The Developer shall be responsible for performing the soil resistivity testing required to complete the ground grid design.
7. **Static Wires** - The Connecting Transmission Owner's existing WD-1 230kV transmission line includes two (2) sets of overhead static wires above the phase conductors. One (1) static wire will be extended overhead into the substation at each new connection. Both static wires at each connection will be connected via underground wire to the substation ground grid through ground conductors at the new structures in the Connecting Transmission Owner's ROW.
8. **Outdoor Conduit & Raceway Systems** – The outdoor cable conduits, trench and raceway systems shall be designed in accordance with NPCC requirements for separation of the A and B cable systems.
9. **Control Building** – A pre-fabricated control house shall be provided for the Patnode Substation. The control house shall be constructed on a concrete base to house the relay, control and monitoring devices. The building shall house the AC and the DC distribution systems in accordance with NPCC and TO requirements, subject to Connecting Transmission Owner's approval. The building will be equipped with indoor lighting and an HVAC system.

#### **10. Protective Relay and Metering:**

The following provides the basic relay and protection philosophy and requirements. The final design will be subject to the approval of the Connecting Transmission Owner and will conform to the Connecting Transmission Owner protection requirements.

- **Primary Line Protection (WPN-1 and PND-1)** – Distance relaying protection is the primary protective function and is provided via a Siemens 7SA522 microprocessor based relay. The relay will trip the line breaker(s) and initiate primary breaker failure protection.
- **Secondary Line Protection (WPN-1 and PND-1)** - A General Electric L90 current differential with distance backup protective relay will be used for secondary line protection. Instantaneous/time over-current function will provide additional back-up

protection. The relay will trip the line breakers and initiate secondary breaker failure protection.

- **Breaker Failure** – When initiated, a Siemens 7SJ61 breaker failure relay will issue a retrip and begin a timer. If the circuit breaker fails to open within a specified period, the breaker failure relay will energize its associated lockout relay, which will trip and block closure of the adjacent breaker(s) and send direct transfer trip to the other end.
- **Transfer Trip** – Two bi-directional direct transfer trip (DTT) systems will be utilized for the Willis-Patnode WPN-1 and Patnode-Duley PND-1 lines. The DTTs will be sent/received via power line carrier and microwave for exceptional reliability. A transfer trip will be sent to Patnode in the event of a breaker failure to trip at Willis substation and vice versa. Similarly DTT signals may be transmitted from Duley to the Patnode Substation and from Patnode Station to Duley.
- **Synch Check Relay** – A GE MLJ100 synch relay will compare voltages across circuit breakers to prevent the breaker from closing in out of phase.
- **Breaker Auto Reclosing** – A Basler BE1-79M multiple shot reclosing relay for each breaker will be utilized in the Synch Check relay to provide auto reclosing of the breakers.
- **Remote Control** – The Connecting Transmission Owner will have the ability to remotely open the Patnode Substation line circuit breakers and motorized line disconnect switches from the Connecting Transmission Owner’s control center.

**11. Fault Recording and Other Monitoring Equipment** – The Connecting Transmission Owner shall specify the equipment requirements for procurement and installation by the Developer. This equipment includes, but is not limited to, a Sequential Event Recorder system and a Digital Fault Recorder system.

**12. Supervisory Control and Data Acquisition (SCADA)** – The SCADA system will provide full functionality of the Patnode Substation to the Connecting Transmission Owner through a Connecting Transmission Owner specified remote terminal unit (“RTU”). The Developer will be provided with read only information from the Patnode Substation through this RTU.

**13. Microwave Radio System** – The Patnode Substation shall be equipped with a microwave system and tower designed in accordance with the “NYPA Technical Specifications for the Communications Systems Supporting the North Country Wind Farm Substations” dated September 18, 2006. Developer shall work with the Connecting Transmission Owner to commission the previously installed microwave equipment at Ryan Substation to complete the microwave communication into the NYPA communications system.

**14. Back-Up Propane Generator** – A permanent mounted propane fueled emergency generator will provide a second backup source of station service power.

**SERVICE AGREEMENT NO. 1774**

**15. DC Power** – One 125V DC station battery system will be provided for primary protection; another identical 125V DC station battery system will be provided for secondary protection. Each battery system will be provided with a dedicated battery charger. The two systems are independent. However, the two systems are provided with a manual cross over connection per NPCC requirements.

**16. Transmission Line:** Developer is designing and procuring steel turning structures within the existing WD-1 230 kV ROW. The Connecting Transmission Owner will construct the turning structures in the 230kV ROW bringing the 230 kV line to the turning structures feeding the Patnode Substation. The Developer shall be responsible for designing, procuring, and constructing the steel monopole structures and transmission work required to bring the 230 kV lines from the ROW turning structures into the dead-end structures within the Patnode Substation.

Connecting Transmission Owner shall update and install the panel labels, equipment labels, drawings and relay settings, if required (plus any additional work required) at Willis and Duley associated with segmentation of the WD-1 line and conversion of the line to WPN-1 and PND-1.

**(B) Cost Estimate for CTOAF and SASUF Patnode Substation**

**CTOAF Estimates**

<b>Description</b>	<b>Cost Estimate</b>
<b>POI Substation Engineering &amp; Design</b>	<b>55,125</b>
<b>POI Substation Construction Management</b>	<b>19,189</b>
<b>Major Substation Equipment</b>	<b>134,505</b>
<b>Construction Contract</b>	<b>350,595</b>
POI Substation Sub-Total:	<b>559,414</b>
Indirects (5% Material)	6,725
POI Substation Contingencies (20%)	111,883
POI Substation Sub-Total	<b>678,022</b>
NYPA Engineering Review	28,215
NYPA Engineering, QA/QC, Project Management	142,930
NYPA Testing & Commissioning	16,500
NYPA Vehicle and Equipment Charges (15% of site labor)	6,518
Project Closeout	10,952
NYPA 230 kV Transmission connections	
NYPA Sub-Total (1):	205,115
NYPA Contingencies 10%	20,512
NYPA Indirects 15%	33,844
NYPA Sub-Total (2):	259,470
Labor Escalation	9,081
Unpaid NYPA Invoices for Drawing and Equipment Review	
<b>NYPA Totals:</b>	<b>268,552</b>

**SERVICE AGREEMENT NO. 1774**

**SASUF Estimates**

<b>Description</b>	<b>Cost Estimate</b>
<b>POI Substation Engineering &amp; Design</b>	<b>496,125</b>
<b>POI Substation Construction Management</b>	<b>172,699</b>
<b>Major Substation Equipment</b>	<b>3,576,795</b>
<b>Construction Contract</b>	<b>3,155,355</b>
Security Materials	69,458
Steel Structures	465,222
Minor Equipment	82,688
Miscellaneous Materials	27,563
Spare Parts	100,000
Commissioning	220,500
Inspections (3rd party independent Engineering Review and Inspections)	90,000
POI Substation Sub-Total	<b>8,456,405</b>
Indirects (5% Material)	178,840
POI Substation Contingencies (20%)	1,691,281
POI Substaion Sub-Total	<b>10,326,526</b>
NYPA Engineering Review	253,935
NYPA Engineering, QA/QC, Project Management	1,286,372
NYPA Testing & Commissioning	148,500
NYPA Vehicle and Equipment Charges (15% of site labor)	58,660
Project Closeout	98,568
NYPA 230 kV Transmission connections	160,000
NYPA Sub-Total (1):	2,006,035
NYPA Contingencies 10%	200,604
NYPA Indirects 15%	330,996
NYPA Sub-Total (2):	2,537,634
Labor Escalation	88,817
Unpaid NYPA Invoices for Drawing and Equipment Review	490,000
<b>NYPA Totals:</b>	<b>3,116,451</b>

### **III. COMMON SYSTEM UPGRADE FACILITIES<sup>2</sup>**

This section identifies the System Upgrade Facilities (“SUFs”) jointly required for the following Class Year 2006 projects: Altona Windfield, Ellenburg Windfield, Clinton Windfield, Marble River Wind Farm, and Marble River Wind Farm II. The SUFs required by all of the identified projects will be referred to as the “Common SUFs.”

The SUFs will be constructed in two phases: Phase I and Phase II. The Phase I work will include the Phase I microwave communications SUFs described in Section II.A., below, and the Willis and Plattsburg Substation upgrades described in the Phase I sections of Section II.B., below.

#### **The Common SUFs include only the following:**

- Microwave Communications SUFs
  - a. Moses (St. Lawrence/FDR Power Plant)
  - b. Massena Substation
  - c. Willis Substation
  - d. Ryan Substation
  - e. Big Hill
  - f. Plattsburgh Substation
  
- Willis and Plattsburgh SUFs, Phase II Only

#### **(A) Microwave Communications System Upgrade Facilities**

Additions and modifications to the existing Connecting Transmission Owner microwave communications system will be made to support the operations of new substations for the Noble Altona (“Duley Substation”), Noble Clinton, Noble Ellenburg (together, “Ryan Substation”) and Marble River and Marble River II (“Patnode Substation”) wind farms.

The system will be comprised of a new digital microwave (backbone) system operating in the 6.7 GHz frequency band with two spur links operating in the 18.7 GHz frequency band. The system will interconnect with the existing Connecting Transmission Owner digital microwave system at the Willis Substation on the west and terminating at the existing microwave system at the Plattsburgh Substation on the east. This project will comprise the backbone system.

The backbone system will use existing towers at Willis and Plattsburgh substations, and require a new 275 ft tower located in Altona at a site called Big Hill and a new 195 ft tower in the new Ryan Substation. The backbone link runs from Willis to Ryan to Big Hill to

---

<sup>2</sup> The description below is the same as the descriptions stated in the Interconnection Agreements for Noble Chateaugay, Noble Ellenburg, and Noble Clinton. However, all construction has been completed. All Common SUF costs have been paid in satisfaction to NYPA by Developer for NYPA-related work.

## SERVICE AGREEMENT NO. 1774

Plattsburgh. As part of individual developer attachment facilities, spur links will run from Ryan Substation to Patnode Substation and from Big Hill to Duley Substation.

The Connecting Transmission Owner's existing analog microwave link between Massena Substation and the St. Lawrence/FDR Moses Dam Site will also be upgraded by adding a digital link to accomplish data communication from the various developer's facilities to Connecting Transmission Owner's operations center at St. Lawrence.

The scope of work at each site will include the following:

### Phase I

#### Willis Substation:

The new communications equipment will be housed in the existing building and the new antenna mounted on the existing tower. The scope of work will include the following:

**Grounding:** The grounding of the existing substation shall be inspected for adequacy, expanded to cover new installations, and the existing Control Building upgraded accordingly for a high frequency grounding system to safeguard electronic and telecommunication equipment from transient overvoltage as recommended by IEEE 1100 and Motorola grounding and Bonding Manual, R56.

**Tower Evaluation:** A structural evaluation of the existing tower and foundation for the new equipment has been performed and the tower was confirmed compliant with Connecting Transmission Owner's and ANSI/TIA 222-G-2005 Class III standards. The tower was originally designed for future additions.

**Antennas:** A 6 foot diameter antenna pointing to Ryan Substation and a working platform will be installed on the existing tower at the 180 ft and 176 ft levels respectively in accordance with the design specifications.

**Radio Equipment:** Radio and associated equipment will be provided in accordance with Connecting Transmission Owner's standards.

#### Ryan Substation:

**Civil/site work:** The microwave tower and equipment shelter will be located within the new substation and no additional site work will be required.

**Foundation:** Reinforced concrete mat foundation with piers.

**Grounding:** Tower will be provided with a lightning protection system in accordance with EIA requirements and will be connected to the substation grounding system. Communications shelter will be grounded to the below grade grounding system according to the Motorola Grounding and Bonding Manual, R56.

## **SERVICE AGREEMENT NO. 1774**

**Station Service:** Power will be supplied from the substation service supply. Power to the DC equipment will be through a UPS battery/charger system, which will have a 12 hour capacity.

**Tower:** 195 ft high free standing galvanized steel lattice tower. Tower to be designed to ANSI/TIA 222-G-2005 Class III standards.

**Antennas:** A 12 ft diameter antenna pointing to Big Hill will be installed 185 ft above ground. A 6 ft diameter antenna pointing to Willis Substation will be installed 160 ft above ground. Provisions will be made in the design for the installation of a 2 ft diameter antenna to the Patnode Substation in accordance with the design specifications.

**Building:** The communications equipment will be installed in a 10 ft x 13 ft x 9 ft high pre-cast concrete building. Building will be designed to meet New York State Building Code requirements.

**Radio Equipment:** Radio and associated equipment will be provided in accordance with Connecting Transmission Owner requirements.

### **Massena to Moses:**

Also included in this System Upgrade Facilities project is the upgrade of the existing analog microwave link between the Massena Substation and the St. Lawrence/FDR Moses Dam site Communications Room with a new digital link. This upgrade link will utilize existing antennas. The waveguide will be replaced in Massena Substation. Equipment and installation will meet the Connecting Transmission Owner requirements.

## **Phase II**

### **Big Hill**

**Civil/site work:** The microwave tower will be located off a wind farm access road which will be constructed by Clinton and Ellenburg. A gravel road will be constructed to the tower site. The tower site and the tower guy wire anchor locations will be cleared, graded level and covered with a 6" layer of crushed stone. Each area will be enclosed with a chain link security fence.

**Foundation:** Reinforced concrete pier foundation for the tower base and communication shelter and reinforced concrete anchor blocks for the guy wires.

**Grounding:** Tower and guy wires will be provided with a lightning protection system connected to a below grade grounding system. Fence and communications shelter will be grounded to the below grade grounding system. Lightning protection and grounding systems will be in accordance with EIA and NEC requirements and the Motorola Grounding and Bonding Manual, R56.

## SERVICE AGREEMENT NO. 1774

**Station Service:** Power will be supplied from the local utility. A back-up propane fueled emergency generator will be provided. The DC equipment power will be supplied through a UPS battery/charger system, which will have a 12 hour capacity.

**Tower:** 275 foot high guyed mast. Tower is designed to ANSI/TIA 222-G-2005 Class III and Connecting Transmission Owner standards.

**Antennas:** A 12 ft diameter antenna pointing to Ryan Substation will be installed 265 ft above ground. A 6 ft diameter antenna pointing to Plattsburgh Substation will be installed 250 ft above ground in accordance with the design specifications.

**Building:** The communications equipment will be installed in a 12 ft x 22 ft x 9 ft high pre-cast concrete building. Building will be designed to meet New York State Building Code requirements.

**Radio Equipment:** Radio and associated equipment will be provided in accordance with Connecting Transmission Owner standards.

### **Plattsburgh Substation:**

The new communications equipment will be housed in the existing building and the new antenna mounted on the existing tower. The scope of work will include the following:

**Tower Evaluation:** A structural evaluation of the existing tower and foundation for the new equipment has been performed. The tower was confirmed compliant with Connecting Transmission Owner's and ANSI/TIA 222-G-2005 Class III standards.

**Antennas:** A 6 ft diameter antenna pointing to Big Hill will be installed on the existing tower 150 ft above ground in accordance with the design specifications.

**Radio Equipment:** Radio and associated equipment will be provided in accordance with Connecting Transmission Owner requirements.

### **(B) Willis and Plattsburgh Substation System Upgrade Facilities**

The Willis Substation and Plattsburgh Substation SUFs will be constructed as described in this Section II.B. and with respect to the Willis Substation, as described below.

## **Phase II**

### **Willis Substation**

The Willis Substation MWP-1 and MWP-2 tap configuration will each be converted to breaker and a half configuration. The conversion will require the addition of three circuit breakers, modifications to the existing structures, station connections, line terminations, and protection system.

## SERVICE AGREEMENT NO. 1774

The existing 230kV 2100 bay will be modified by the addition of a third breaker to create separate terminals for the MW-2 and WRY-2 segments of the existing MWP-2 transmission line. PT's and CVT's will be added in conjunction with the line relaying modifications.

A new 2300 bay will be added north of the existing 2200 bay in an area previously designated by Connecting Transmission Owner for expansion. The new 2300 bay will include two new 230kV circuit breakers, SF6 type, 2000A continuous circuit, rated 900kV, 63 kA circuit breakers, associated disconnect switches, and line terminal equipment to accommodate the relocated WP-1 transmission line. The WP-1 transmission line will be re-designated WPN-1. New PT's and CCVT's will be added in conjunction with the new line and relaying systems will be installed for the WPN-1 line.

The MW-1 line will terminate in the 2200 bay. The existing MWP-1 line primary protection is a blocking carrier scheme using electromechanical relays with ON-OFF carrier equipment. The existing MWP-1 line secondary protection utilizes electromechanical relays to provide backup distance protection. New CCVT's will be added in the 2200 bay.

The existing Direct Transfer Trip is accomplished via audio tone equipment over single side band power line carrier channels. The existing primary and secondary MWP-1 line protection will remain and be re-designated as MW-1 line protection.

The new equipment will include:

- 230kV Circuit Breakers
- 230kV Disconnect Switches
- Potential Transformers
- Capacitive Voltage Transformers
- Primary Protection Panels
- Secondary Protection Panels
- Communication Racks
- Termination Panels
- Wave Traps and Line Tuners

### WRY-2 Line

The primary line relaying will include:

- Pilot Scheme; directional comparison unblocking (DCU) and primary direct transfer trip (DTTP) over power line carrier
- New numerical multifunction relay for phase and ground fault protection
- New FSK PLC equipment for DCU
- Reconfigure existing FSK PLC equipment for DTTP
- New hybrids
- Additional auxiliary devices, test switches, lockout relays, etc.

The secondary line relaying will include:

- Pilot Scheme; current differential with secondary DTT (DTTS) over digital microwave.

## SERVICE AGREEMENT NO. 1774

- New current differential relay
- New Digital multiplexer and/or fiber optic interface unit
- Additional auxiliary devices, test switches, lockout relays, etc.

### WPN-1 Line

The primary line relaying will include:

- Pilot Scheme; directional comparison unblocking (DCU) and primary direct transfer trip (DTTP) over power line carrier
- New numerical multifunction relay for phase and ground fault protection
- New FSK PLC equipment for DCU
- New FSK PLC equipment for DTTP
- New hybrids
- Additional auxiliary devices, test switches, lockout relays, etc.

The secondary line relaying will include:

- Pilot Scheme; current differential with secondary DTT (DTTS) over digital microwave
- New current differential relay
- New Digital multiplexer and/or fiber optic interface unit
- Additional auxiliary devices, test switches, lockout relays, etc.

### New 230kV Circuit Breakers

New primary and secondary breaker failure relays and their associated lockout relays and test switches are added for each new breaker.

Various switches associated for breaker control are added for each new breaker.

### Plattsburgh Substation

The Plattsburgh Substation WP-1 and WP-2 lines will be re-designated DP-1 and RYP-2 respectively. The existing primary and secondary line relaying systems will be replaced with numerical relay systems as shown below.

The new equipment will include:

- Phase C Line Tuners
- Phase C Wave Trap
- Primary Protection Panels
- Secondary Protection Panels
- Communication Racks
- Termination Panels

**SERVICE AGREEMENT NO. 1774**

DP-1 and RYP-2 Lines

The primary line relaying will include:

- Pilot Scheme; directional comparison unblocking (DCU) and primary direct transfer trip (DTTP) over power line carrier
- New numerical multifunction relay for phase and ground fault protection
- New Digital multiplexer and/or fiber optic interface unit
- Additional auxiliary devices, tests switches, lockout relays, etc.

The secondary line relaying will include:

- Pilot Scheme; current differential with secondary DTT (DTTS) over digital microwave
- New current differential relay
- New Digital multiplexer and/or fiber optic interface unit
- Additional auxiliary devices, test switches, lockout relays, etc.

**(C) Cost Estimates**

**Common System Upgrade Facilities Cost Estimate\***

<b>Description</b>	<b>Installation Cost</b>
<b>Microwave Communication System</b>	\$3,619,260
<b>Willis Substation</b>	\$5,873,200
<b>Plattsburgh Substation</b>	\$2,408,200
<b>Total Common System Upgrade Facilities Cost</b>	<b>\$11,900,660**</b>

\* Note that this cost estimate does not include the cost estimate for the Patnode Substation Ring Bus Facilities and CTOAF, which is included in the cost estimate set forth in Section II(D) of this Appendix A.

\*\* The Class Year 2006 Facilities Study allocated \$250,000 of this total System Upgrade Facilities cost among only the Altona Windfield, Ellenburg Windfield, and Clinton Windfield Large Generating Facilities. The remaining \$11,650,660 was allocated—equally among Altona Windfield, Ellenburg Windfield, Clinton Windfield, Marble River Wind Farm, and Marble River Wind Farm II.

**SERVICE AGREEMENT NO. 1774**

<b>Description</b>	<b>Installation Cost</b>
Willis Tower Evaluation	\$10,400
Willis Communication Equipment	\$305,000
Plattsburgh Tower Evaluation	\$10,400
Plattsburgh Communication Equipment	\$305,000
Clinton 195 ft. Tower	\$214,000
Clinton Communication Equipment	\$126,000
Clinton Building Battery & Accessories	\$72,000
Big Hill 275 ft. Tower	\$255,000
Big Hill Communication Equipment	\$250,000
Big Hill Building, Battery, Gen-Set & Accessories	\$170,000
Massena/STL Microwave System Upgrade	\$300,000
Spare Parts	\$68,000
Big Hill Land Acquisition	\$65,000
Big Hill Access Roads, Survey & Site Clearing	\$135,000
Licensing and Permitting	\$30,000
Engineering	\$120,000
Construction Management	\$140,000
Noble Development Cost	\$60,000
Testing and Commissioning	\$60,000
Other - Equipment Cost (15% of install man-hours)	\$42,000
Other - Engineering, QA / QC, Project Mgt.	\$150,000
Subtotal	\$2,887,800
Contingency 20%	\$577,560
Other Indirects 15%	\$153,900
<b>Total Microwave System Upgrade</b>	<b>\$3,619,260</b>

**SERVICE AGREEMENT NO. 1774**

<b>Description</b>	<b>Installation Cost</b>
230 kV Circuit Breakers	\$330,000
230 kV Disconnects	\$100,000
Six Current Transformers	\$48,000
Six Voltage Transformers	\$64,000
Primary Protection Panels	\$150,000
Secondary Protection Panels	\$150,000
Communication Panels	\$56,000
Control Panels	\$120,000
Installation of Equipment	\$700,000
Install Relay and Control Equipment	\$300,000
Overhead Line Rework	\$240,000
Site work	\$40,000
Rework and rewire existing panels	\$160,000
Structural Steel	\$150,000
Demolition	\$40,000
Foundation	\$220,000
Special Line Protection	\$100,000
Willis 230 kV Bus Connector Upgrade	\$30,000
Wave Trap (2) - Single Phase	\$56,000
Transmitter	\$24,000
Receiver	\$24,000
Materials	\$32,000
Wave Trap Installation w/foundation, steel	\$80,000
Land Acquisition / Site Work	\$150,000
Construction Management	\$230,000
Engineering	\$292,000
Testing and Commissioning	\$165,000
Other - Engineering, QA / QC, Project Mgt.	\$500,000
Other - Equipment Cost (15% of install man-hours)	\$110,000
Subtotal	\$4,661,000
Contingency 20%	\$932,200
Others Indirects 15%	\$280,000
<b>Total Willis Station System Upgrades</b>	<b>\$5,873,200</b>

**System Upgrade Facilities Cost Estimate - Plattsburgh Substation**

Description	Installation Cost
Primary protection panels	\$108,000
FSK Plc panels	\$72,000
Secondary Panels	\$108,000
Digital Multiplexer	\$28,000
Three current transformers	\$24,000
Digital Multiplexer	\$28,000
Three current transformers	\$18,000
Three voltage transformers	\$24,000
Installation of panels	\$100,000
Conduit, cable and wiring	\$200,000
Rework and rewire existing panels	\$60,000
Other - Relay & Control Installation	\$200,000
Special Line Protection	\$100,000
Engineering	\$220,000
Construction Management	\$105,000
Noble Development Cost	\$100,000
Other - Equipment Cost (15% of install man-hours)	\$36,000
Testing and Commissioning	\$80,000
Other - Engineering, QA / QC, Project Mgt.	\$300,000
Subtotal	\$1,911,000
Contingency 20%	\$382,200
Others Indirects 15%	\$115,000
<b>Total Plattsburgh System Upgrades</b>	<b>\$2,408,200</b>

**IV. POWER SYSTEM STABILIZERS PURSUANT TO LGIA SECTION 5.4.**

N/A

**V. TAX LIABILITY**

As of the Effective Date, the Developer shall not have any tax liability under Article 5.17 of this Agreement.

**VI. TRANSFER OF PROPERTY**

Upon completion of construction, testing and acceptance by the Connecting Transmission Owner of the Patnode Substation, Developer will convey fee interest in the Patnode Substation and sub-easement interests to the site access road as depicted in Survey Maps attached to this Appendix A as Figure [2], Figure [2A], Figure [2B] to Connecting Transmission Owner by warranty deed and will transfer to Connecting Transmission Owner title to the Connecting Transmission Owner's Attachment Facilities and System Upgrade Facilities constructed thereon, free and clear of any liens or encumbrances. Connecting Transmission Owner will provide to Developer an easement over such transferred property to allow Developer access to the DAF and CTOAF. Developer shall, through the term of this Agreement, be solely responsible for maintenance and repairs, including snow removal, of the site access road to provide accessibility to the Patnode Substation.

**VII. OPERATION & MAINTENANCE EXPENSES**

Pursuant to Section 10.5 of this Agreement, Developer shall pay the reasonable expenses (including overheads) for the operation, maintenance, repair and replacement of Connecting Transmission Owner's Attachment Facilities. Such expenses are calculated as follows:

- a. Contractor expenses for labor, equipment and materials. These expenses shall be invoiced as the actual amount of the Contractors' invoices. Connecting Transmission Owner shall also be entitled to a fee of 5 % of such amount(s).
- b. Connecting Transmission Owner's labor, craft and salaried personnel directly working on the operation, maintenance or repair of the Connecting Transmission Owner Attachment Facilities. These expenses shall be invoiced on the basis of Connecting Transmission Owner's standard labor rate times the number of hours worked (including adjustment for overtime hours, if applicable). Such standard rate is subject to change in accordance with Connecting Transmission Owner's normal budgeting practices.
- c. Equipment and materials purchased by the Connecting Transmission Owner (other than those covered under subsection (a), above). These expenses shall be invoiced on the basis of the actual cost of such material. Connecting Transmission Owner shall also be entitled to a fee of 15% of such amount(s).
- d. Use of vehicles and construction equipment. These expenses shall be invoiced at Connecting Transmission Owner's cost. Connecting Transmission Owner shall also be entitled to a fee of 10% of such amount(s).
- e. Miscellaneous expenses (e.g. local utility charges for power; local telephone/communication fees; other fees such as FAA licenses). These expenses shall be invoiced at Connecting Transmission Owner's cost. Connecting Transmission Owner shall also be entitled to a fee of 5% of such amount(s).

FIGURE 1

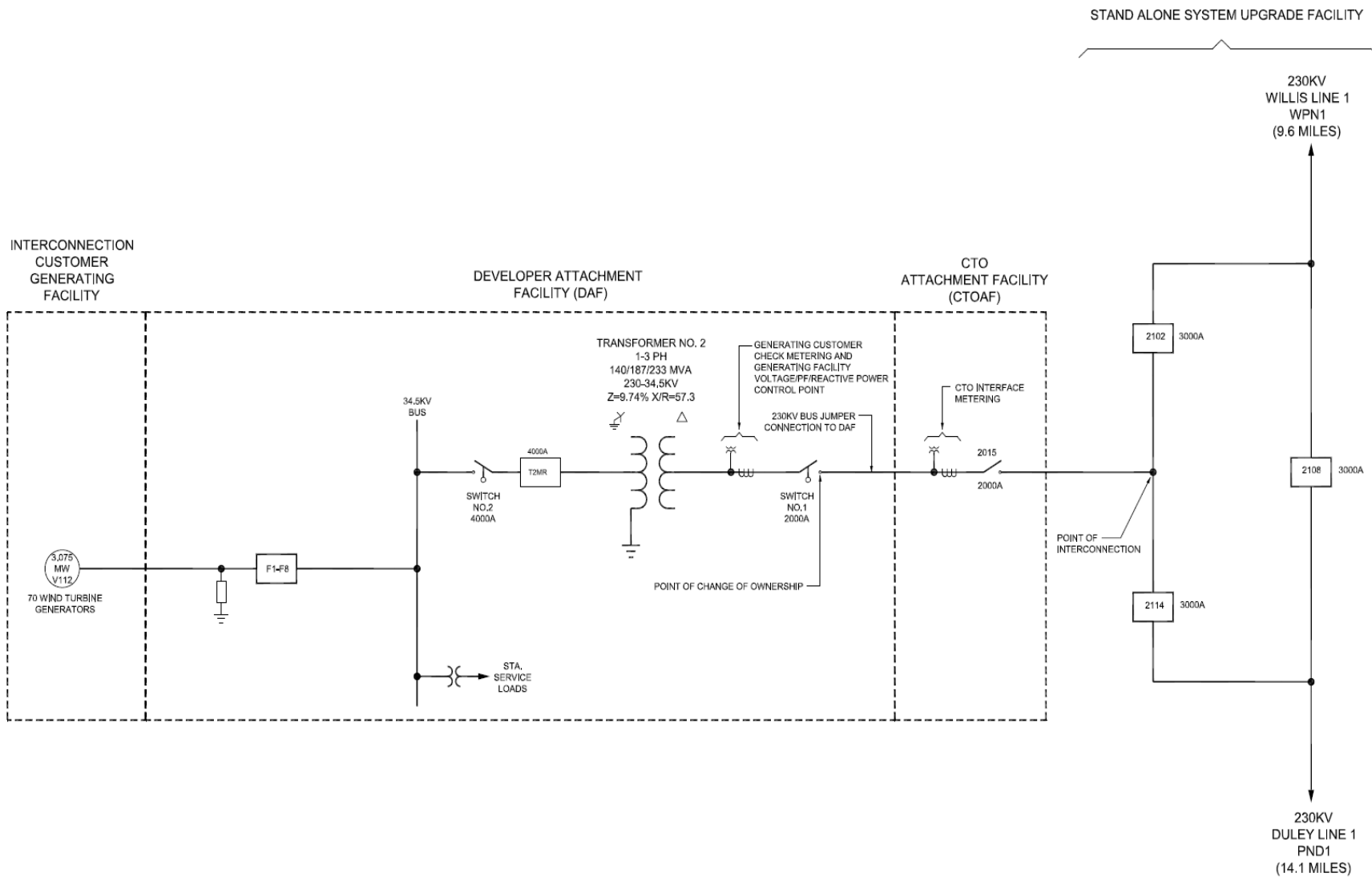



FIGURE 2A

TOWN OF CLINTON  
COUNTY OF CLINTON  
MAP NO. 66-414  
PARCEL NO. 414

POWER AUTHORITY OF THE STATE OF NEW YORK  
ST. LAWRENCE - FDR PROJECT  
MOSES - WILLIS - PLATTSBURGH TRANSMISSION LINE

SHEET 1 OF 2 SHEETS

SURVEY AND DESCRIPTION PREPARED  
UNDER DIRECTION OF THE POWER  
AUTHORITY OF THE STATE OF NEW YORK.  
SURVEY NOTES ON FILE IN THE OFFICE  
OF SUCH AUTHORITY.

ALTERATION OR ADDITION TO A SURVEY  
MAP BEARING THE SEAL OF A LICENSED  
LAND SURVEYOR IS A VIOLATION OF  
SECTION 7130, SUBDIVISION 2 OF THE  
NEW YORK STATE EDUCATION LAW.

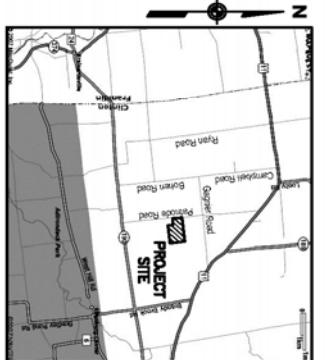
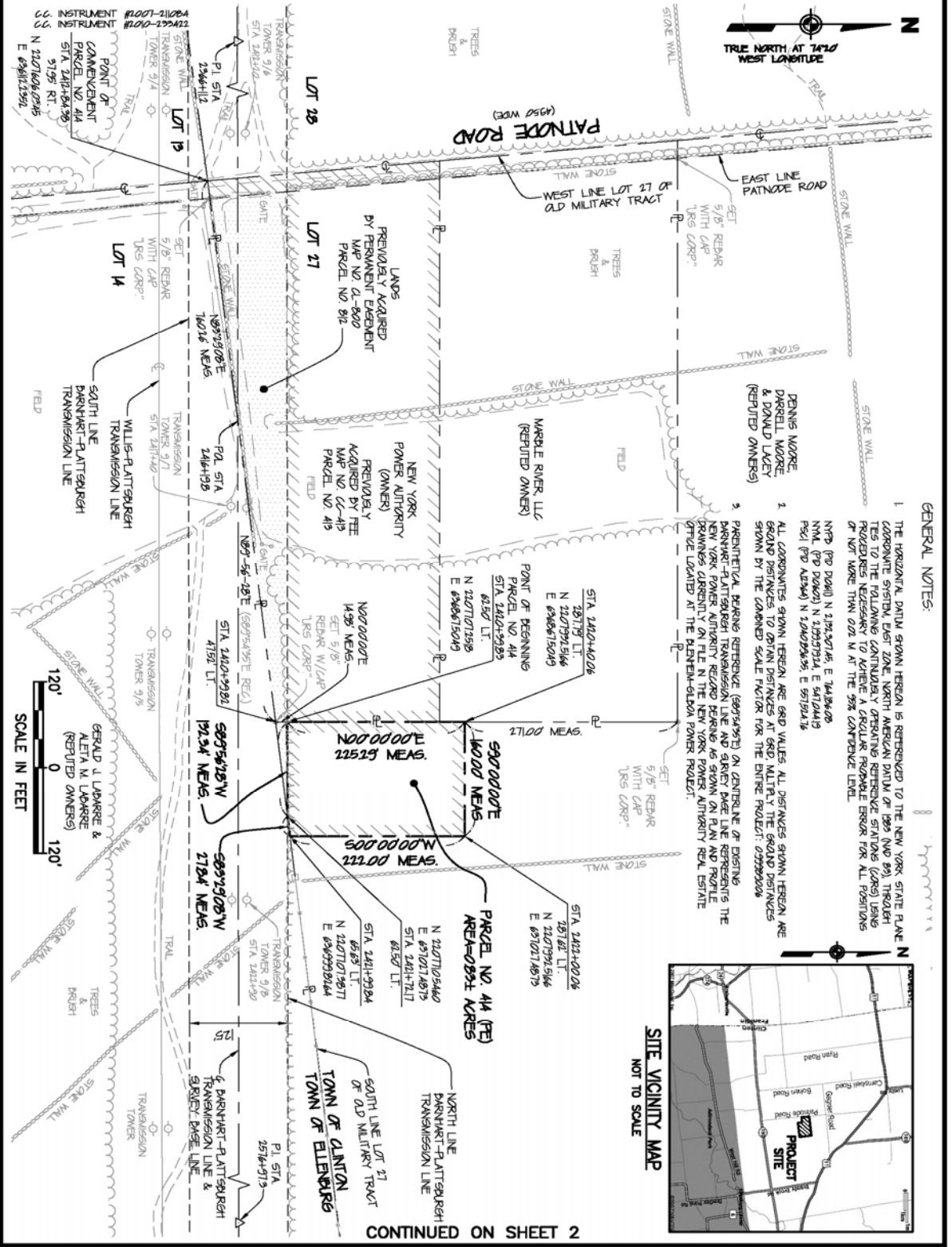

GENERAL NOTES:

1. THE HORIZONTAL DATA SHOWN HEREON IS REFERENCED TO THE NEW YORK STATE PLANE COORDINATE SYSTEM, EAST ZONE, NORTH AMERICAN DATUM OF 1983 (NAD 83). THROUGH THIS TO THE FOLLOWING CONTIGUOUSLY ADJACENT REFERENCED STATIONS (GORS) USING PROCEDURES NECESSARY TO ACHIEVE A CIRCULAR PROPORTION ERROR FOR ALL POSITIONS OF NOT MORE THAN 0.02 M AT THE 5% CONFORMANCE LEVEL.
2. ALL CORNER POINTS SHOWN HEREON ARE 660 FEET. ALL DISTANCES SHOWN HEREON ARE SHOWN BY THE CANNONED SCALE FACTOR FOR THE ENTIRE PROJECT: 0.999999999.
3. PARSHART-PLATTSBURGH TRANSMISSION LINE AND SOUTHERN POWER LINE REPRESENTS THE NEW YORK POWER AUTHORITY RECORD BEARING AS SHOWN ON PLAN AND PROFILE DRAWINGS CURRENTLY ON FILE IN THE NEW YORK POWER AUTHORITY REAL ESTATE OFFICE LOCATED AT THE PLATTSMOUTH TOWER POWER PROJECT.

CONTINUED ON SHEET 2

L:\IT\2023\00000\KAP\NYP\A Substation Application\Map No 66-414-Rowland H 4/17/23.dwg

FIGURE 2B

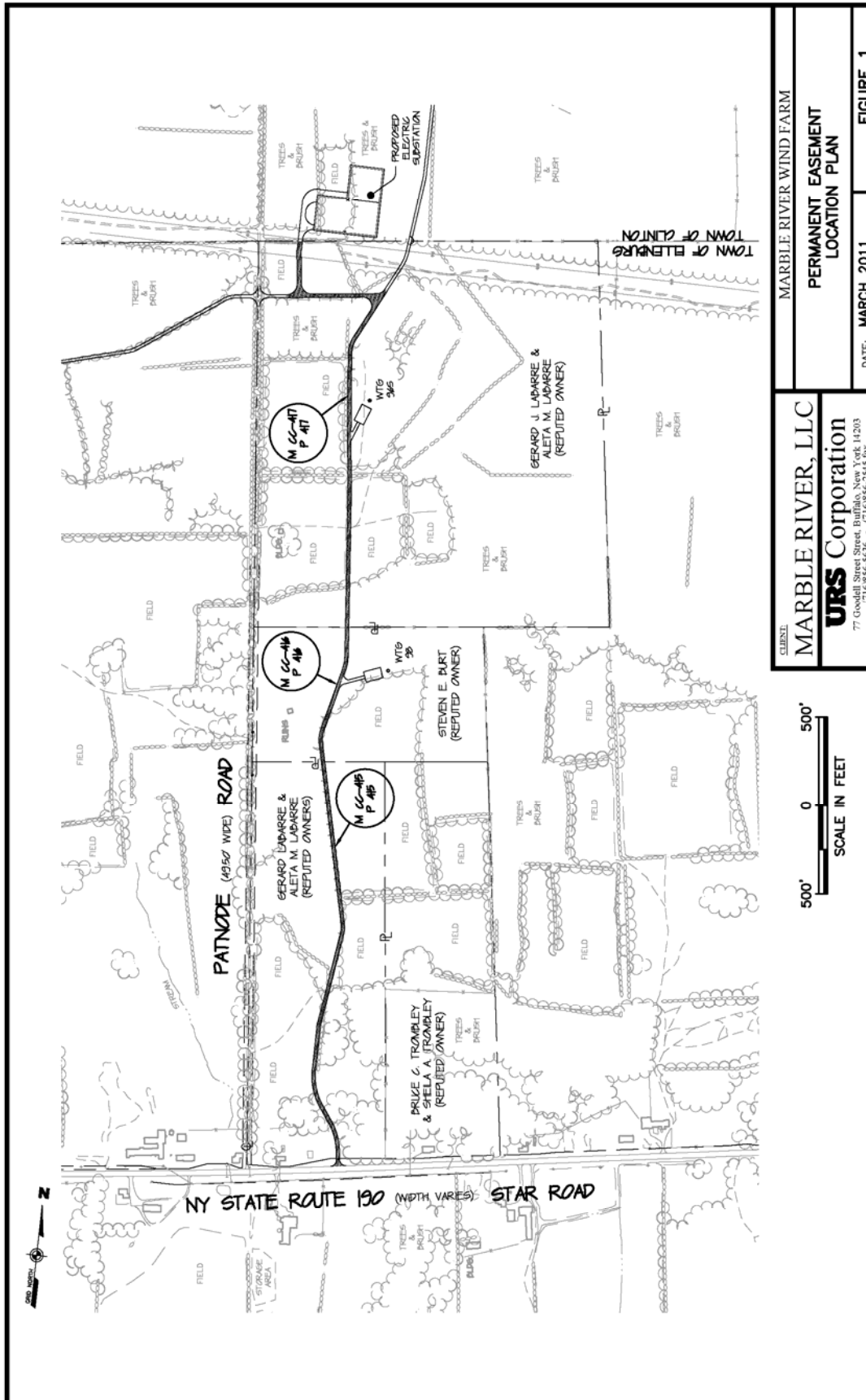

I:\VIT1030\CAD\NIFA Appropriations\Keymap.dwg [d] 9/26/11 .jbs

**APPENDIX B**

**Milestones**

**I. SELECTED OPTION PURSUANT TO ARTICLE 5.1**

The Connecting Transmission Owner’s engineering, procurement and construction obligation shall be performed in accordance with the “Standard Option.” The Developer’s engineering, procurement and construction obligation shall be performed in accordance with the “Option to Build.” The Parties have agreed to the division of responsibility and scope as described in Appendix A.

**II. MILESTONES**

Item	Milestone	Start	Finish	Responsible
1	Conduct Marble River Kick-Off Meeting for 2011 Start.		Complete	Developer
2	Submit current design drawings, calculations, and equipment specifications for SASUF/CTOAF (230kV Patnode Substation).		Complete	Developer
3	Submit relay and control drawings for DAF (35kV MR Station).		Complete	Developer
4	Review and provide comments on, design drawings, specifications, and calculations of SASUF and CTOAF (230kV Patnode Substation), and DAF (35kV MR Station) relay and control drawings.	Jan-11	Complete	Connecting Transmission Owner
5	Incorporate review comments from NYPA, DCDC, and Project Management Criteria and issue final design package for CTOAF/SASUF(230kV Patnode Substation) to NYPA.	Mar-11	Complete	Developer
6	NYPA review and comments on final design package for CTOAF/SASUF(230kV Patnode Substation)	May-11	Complete	Connecting Transmission Owner

**SERVICE AGREEMENT NO. 1774**

Item	Milestone	Start	Finish	Responsible
7	Incorporate NYPA review and comments on final design package for CTOAF/SASUF(230kV Patnode Substation)	May-11	Complete	Developer
8	Issue IFC drawings	Oct-11	Complete	Developer
9	Start construction of SASUF and Connecting Transmission Owner Attachment Facilities (CTOAF) (230kV Patnode Substation)	Oct-11	Complete	Developer
10	Start construction of DAF(35kV MR Station) below ground and above ground.	Oct-11	Complete	Developer
11	Issue Relay Coordination Study		Complete	Developer
12	Complete construction of SASUF and 2 steel Turning Structures and Conductor to SASUF Take Offs). (230kV Patnode Substation)		Complete	Developer and Connecting Transmission Owner
13	Complete construction of CTOAF (230kV Patnode Station)		Complete	Developer
14	Complete construction of partial DAF (35kV MR Station) effecting CTOAF/SASUF (230kV Patnode Substation		Complete	Developer
15	Complete all functional tests for CTOAF/SASUF (230kV Patnode Substation)		Jun-12	Developer
16	Issue CTOAF/SASUF (230kV Patnode Substation) as-built (red line) drawings and Turnover Packages(TOPs) for CTO review and approval	May-12	Jun-12	Developer
17	Transfer care, custody, and control of CTOAF/ SASUF (230kV Patnode substation) to CTO	May-12	Complete	Developer
18	Cut in outage for SASUF (230kV Line)	May-12	Complete	Developer

**SERVICE AGREEMENT NO. 1774**

Item	Milestone	Start	Finish	Responsible
19	In Service (Developer receives Backfeed Power From Connecting Transmission Owner)	Jun-12	Jun-12	Developer
20	Complete all 35kV functional tests and Verifications of DAF (35kV MR Station)		Jun-12	Developer
21	Start Energizing Collection System Circuits and start Developer Turbine testing (Initial power to NYPA)	Jun-12	Sep-12	Developer
22	Wind Turbine Commissioning	Jun-12	Oct-12	Developer
23	Commercial Operation Date	Oct-12	Oct-12	Developer
24	SUF and TOAF Project close out. Complete and submit all required Documentation (CTOAF/SASUF Record Drawings, Punch List Items, Final Turnover Packages), including remaining Record DAF drawings		Jan-13	Developer
25	DAF Project close out completed (including punch list items)		Mar-13	Developer
26	CTOAF/SASUF (230kV Patnode Station) Property Transfer		Mar-13	Developer

The following notes apply to all work performed on SASUF and CTOAF Transmission Attachment Facilities relative to the Marble River Project:

- Developer shall submit to Connecting Transmission Owner copies of all required Patnode construction permits including all supporting documentation such as calculations, applications and drawings within five days of the execution of this Interconnection Agreement.
- Connecting Transmission Owner work durations do not include holiday work; if a holiday occurs in the calendar during an event, then it is extended day-to-day.
- All Connecting Transmission Owner outage durations based upon good weather; inclement weather will extend outages.
- Transmission System emergencies take precedence over all other work and could significantly impact the schedule and durations.

## SERVICE AGREEMENT NO. 1774

- Connecting Transmission Owner schedules its resources months in advance, and its ability to reschedule manpower is limited by resource allocation to other Connecting Transmission Owner projects and tasks. Missing a scheduled task or milestone date may result in some delay before TO can reschedule its manpower to work on the assigned task.
- The Turnover Package consists of the following documents: picture of equipment nameplate, equipment documentation, Vendor O&M manual, Vendor drawings, QA/QC documents, installation commissioning, Engineer of Record Professional Engineer certification, certificate of occupancy, “as built” color markup of design drawings, warranties, etc.
- Developer shall be responsible for all fines imposed on Connecting Transmission Owner by a Governmental Authority or Applicable Reliability Councils due to any Developer action or inaction relating to the Attachment Facilities or SASUF up until the date of transfer of ownership of such facilities from Developer to Connecting Transmission Owner.

### III. TRIGGER DATES FOR COMMON SUFs<sup>3</sup>

The Common SUFs will be installed in accordance with the Trigger Dates for completion of the Common SUFs, set forth on Schedule A to this Appendix B, attached hereto, and consistent with the Milestone Schedule set forth in Section II of this Appendix B. Under certain circumstances described below, if Clinton and Ellenburg are unable to meet a Trigger Date, the Connecting Transmission Owner and NYISO may require Clinton and Ellenburg to cease all existing efforts to construct or develop the Common SUFs and to transfer any such rights to Connecting Transmission Owner or Connecting Transmission Owner’s designee.

Notwithstanding the foregoing, it is understood and agreed that an occurrence of an “Uncontrollable Timing Event” shall excuse Clinton and Ellenburg’s obligation to meet affected Trigger Dates until applicable replacement Trigger Dates have been agreed upon pursuant to Section III(b)(i) below. An “Uncontrollable Timing Event” shall mean an event that causes delays in meeting the Trigger Date(s) as a result of (a) an event of Force Majeure and/or (b) actions by the Connecting Transmission Owner, NYISO, NPCC, federal governmental authorities and/or state governmental authorities, and where: (x) such event(s) are beyond Clinton and Ellenburg’s control; (y) alter(s) Clinton and Ellenburg’s scope of work as set forth in Appendix A; and (z) there would not have been a delay that causes Clinton and Ellenburg to be unable to meet the Trigger Date(s) but for such event(s). Nothing herein shall: (i) alter or

---

<sup>3</sup> The description below is the same as the descriptions stated in the Interconnection Agreements for Noble Chateaugay, Noble Ellenburg, and Noble Clinton. However, all construction has been completed. All Common SUF costs have been paid in satisfaction to NYPA by Developer for NYPA-related work.

## SERVICE AGREEMENT NO. 1774

abrogate Parties' excuse from performance for events of Force Majeure (as defined in this Interconnection Agreement); or (ii) impose any increased obligation, liability or responsibility on Connecting Transmission Owner or the NYISO to perform its obligations pursuant to this Interconnection Agreement.

Except to the extent discussed above, Clinton and Ellenburg and Connecting Transmission Owner agree that neither the Milestone Schedule set forth in Section II of this Appendix B, nor the Trigger Date Schedule set forth on Schedule A to this Appendix B shall be modified in any way that will change or will likely change a Trigger Date without the prior written consent of Noble Altona Windpark, LLC ("Altona") and Marble River, LLC ("Marble River") (as applicable).

- (a) If Clinton and Ellenburg determine it will be unable to meet one or more Trigger Date(s), Clinton and Ellenburg shall notify Connecting Transmission Owner, NYISO, Altona and Marble River in writing within five (5) Business Days of such determination. In its notice, Clinton and Ellenburg shall specify (i) whether it is claiming that its inability to meet any such Trigger Date(s) is/are attributable to Uncontrollable Timing Event(s), (ii) the reasons supporting such claim and, if known, the anticipated date the Uncontrollable Timing Event(s) will end, and (iii) its revised timeframe for meeting the Trigger Date(s).
- (b) Connecting Transmission Owner and NYISO shall promptly review Clinton and Ellenburg's notice and promptly notify Altona and Marble River of Connecting Transmission Owner's and NYISO's determination.
  - (i) If Connecting Transmission Owner and NYISO jointly have a reasonable basis for determining, and in fact determine, that Clinton and Ellenburg's failure to meet the Trigger Date(s) is due to an Uncontrollable Timing Event(s), then (A) Clinton and Ellenburg shall be relieved of its obligation to meet the Trigger Date(s) in question until the Uncontrollable Timing Event ends, and (B) Clinton and Ellenburg, Connecting Transmission Owner, NYISO, Marble River and Altona shall cooperate in good faith to negotiate reasonable replacement Trigger Date(s).
  - (ii) If Connecting Transmission Owner and NYISO jointly have a reasonable basis for determining, and in fact determine, that Clinton and Ellenburg's failure to meet the Trigger Date(s) is not due to an Uncontrollable Timing Event, then Clinton and Ellenburg shall be given a right to cure its failure to meet the Trigger Date within twenty (20) calendar days after receipt of Connecting Transmission Owner's and NYISO's determination.
- (c) If, absent notification from Clinton and Ellenburg pursuant to Section III(a) above, NYISO and/or Connecting Transmission Owner reasonably believe that Clinton and Ellenburg will be unable to, or has failed to, meet a Trigger Date, NYISO and Connecting Transmission Owner shall notify Clinton and Ellenburg in writing with copies to Altona and Marble River, requesting Clinton and Ellenburg to provide responses to the following: (i) whether or not Clinton and Ellenburg believe they will be unable to or has failed to meet any such Trigger Date; (ii) whether Clinton and Ellenburg believe any

## SERVICE AGREEMENT NO. 1774

inability to meet a Trigger Date is attributable to an Uncontrollable Timing Event(s); (iii) the reasons supporting any such claim and the anticipated date the Uncontrollable Timing Event will end; and (iv) its estimate for completing the task associated with the missed Trigger Date(s). Within (5) Business Days after Clinton and Ellenburg's receipt of the NYISO and/or Connecting Transmission Owner notice in this Section III(c), Clinton and Ellenburg shall respond in writing to NYISO, Connecting Transmission Owner, Altona and Marble River. NYISO and Connecting Transmission Owner shall promptly review Clinton and Ellenburg's response. The provisions of Section III(b) above shall apply following such review.

- (d) If Clinton and Ellenburg does not meet a Trigger Date for any reason other than the occurrence of an Uncontrollable Timing Event, and has failed to cure such failure of performance within the period set forth in Section III(b)(ii) above, then Connecting Transmission Owner and NYISO have the right (but not the obligation) to demand that Clinton and Ellenburg cease all existing efforts to construct or develop the Common SUFs, and to transfer any such rights to Connecting Transmission Owner or Connecting Transmission Owner's designee (which may include Marble River). (Connecting Transmission Owner's designee shall be the "Transferee"). A decision regarding such demand will take into account Marble River's scheduled in-service date (which shall be no earlier than October 1, 2008), among other considerations. As part of any transfer to Connecting Transmission Owner or Transferee, Connecting Transmission Owner and NYISO may demand that Clinton and Ellenburg transfer or convey to the Connecting Transmission Owner or Transferee (as applicable) title to, possession of and control of any and all equipment and services procured for the purpose of constructing the Common SUFs, and Clinton and Ellenburg shall immediately transfer such equipment and services free and clear of any liens or other encumbrances to the Connecting Transmission Owner or Transferee (as applicable) accordingly. The terms and conditions with respect to the transfer of such equipment and services shall be customary for transactions of this type in the electric power industry, as reasonably determined by Clinton and Ellenburg and Connecting Transmission Owner jointly.

## IV. COST ALLOCATION<sup>4</sup>

Clinton and Ellenburg will be fully responsible for costs in excess of \$11.65 million incurred to complete the Common SUFs, except to the extent that the excess cost is incurred as a result of an "Uncontrollable Cost Event." An "Uncontrollable Cost Event" shall mean an event that causes costs increases as a result of (i) an event of Force Majeure, (ii) the implementation of the results of the special protection scheme study being conducted as referenced in Appendix 4 (NYPA Phase 2 Protection Design Criteria Document), Paragraph 3.9 of the SUF Report (as such term is defined in Appendix A of this LGIA), (iii) additional channels on the Transwave

---

<sup>4</sup> The description below is the same as the descriptions stated in the Interconnection Agreements for Noble Chateaugay, Noble Ellenburg, and Noble Clinton. However, all construction has been completed. All Common SUF costs have been paid in satisfaction to NYPA by Developer for NYPA-related work.

## **SERVICE AGREEMENT NO. 1774**

Communications Systems for the Willis to Plattsburgh circuit requested by NYPA (as described in the August 8, 2007, letter from Noble Constructors, LLC to Marble River as Change Order 1 with a cost impact of \$210,954.00), (iv) after transfer pursuant to Section III(d) above, negligence or willful misconduct on the part of the Connecting Transmission Owner or Transferee, as applicable, and/or (v) after transfer pursuant to Section III(d), failure of the Connecting Transmission Owner or Transferee, as applicable, to take steps reasonably necessary to complete the Common SUFs in a timely manner.

In the event that excess cost is incurred to complete the Common SUFs as a result of an Uncontrollable Cost Event as set forth in subsections (i), (ii) or (iii) above, then such costs will be allocated among the Clinton, Ellenburg, Altona and Marble River pursuant to the allocation percentages determined pursuant to Attachment S of the NYISO OATT, and in no event shall such excess costs be the responsibility of Connecting Transmission Owner.

In the event that excess cost is incurred to complete the Common SUFs as a result of an Uncontrollable Cost Event as set forth in subsections (iv) or (v) above, then: (A) to the extent that Connecting Transmission Owner is responsible for such costs pursuant to the procedures set forth in Attachment S of the NYISO OATT, as such responsibility is determined in accordance with the next paragraph, such costs will be allocated to Connecting Transmission Owner; (B) to the extent that Connecting Transmission Owner is not responsible for such costs pursuant to the procedures set forth in Attachment S of the NYISO OATT and Marble River is the Transferee, such costs will be allocated among the Clinton, Ellenburg, Altona and Marble River pursuant to the allocation percentages determined pursuant to Attachment S of the NYISO OATT; and (C) to the extent that Connecting Transmission Owner is not responsible for such costs pursuant to the procedures set forth in Attachment S of the NYISO OATT and neither Connecting Transmission Owner nor Marble River is the Transferee, such costs will be allocated equally among the Clinton, Ellenburg and Altona.

The Parties agree that in determining the extent of Connecting Transmission Owner's responsibility (if any) for costs pursuant to the procedures set forth in Attachment S of the NYISO OATT, only the Connecting Transmission Owner's actions (or inaction) shall be considered; Connecting Transmission Owner shall not be responsible for the actions (or inaction) of any Transferee.

**SERVICE AGREEMENT NO. 1774**

**Schedule A to Appendix B**

**Trigger Date Schedule<sup>5</sup>**

Task Descriptions	Status	Trigger Date
<b>Willis – Phase II</b>		
Design Complete – Submitted to Connecting Transmission Owner	Complete	7-Mar-08
Circuit Breakers/CCVT Ordered	Complete	20-Jul-07
Circuit Breakers Delivered	Complete	11-Nov-07
CCVT Delivered	Complete	15-Feb-08
Noble Construction Started	Complete	15-Nov-07
Noble Bay 2300 Construction Complete	Complete	6-Jun-08
Connecting Transmission Owner Completes Review of Trn Ovr Package and Issues Punchlist	Complete	7-Jul-08
Noble Completes Functional Items* on Punchlist	Complete	8-Aug-08
<b>Plattsburgh – Phase II</b>		
Design Complete- Submitted to Connecting Transmission Owner**	Complete	19-Nov-07
Long Lead Equipment Ordered	Complete	4-Sep-07
Long Lead Equipment Delivered	Complete	3-Mar-08
Noble Construction Started	Complete	15-Mar-08
Noble Completes WP-2 installation – [Outdoors]	Complete	20-May-08
Connecting Transmission Owner Completes Review of Turn Over Package and Issues Punchlist	Complete	15-Jun-08
Noble Completes Functional Items* on Punchlist	Complete	15-Jul-08
<b>Microwave:</b>		
Design Complete- Submitted to Connecting Transmission Owner	Complete	20-Jul-07
Long Lead Equipment Ordered	Complete	20-Jul-07
Long Lead Equipment Delivered	Complete	1-Oct-07
Noble Construction Started	Complete	10-Sep-07
Noble Construction Completed	Complete	30-May-08

<sup>5</sup> The description below is the same as the descriptions stated in the Interconnection Agreements for Noble Chateaugay, Noble Ellenburg, and Noble Clinton. However, all construction has been completed. All common SUF costs have been paid in satisfaction to NYPA by Developer for NYPA-related work.

## **SERVICE AGREEMENT NO. 1774**

- \* The term “Functional Items” refers to all work comprising the relevant scope, including all materials and components, but excluding minor or non-functional punch list items (*i.e.*, the list of items of Work remaining to be completed which are generally cosmetic in nature and/or not required for the safe and lawful operation of the Facility), have been installed, erected, aligned, and adjusted at the site in a non-operating condition, substantially in accordance with the technical specifications and as acceptable to Connecting Transmission Owner.
  
- \*\* Such design submission shall be reasonably complete and allow the work to move forward.

**APPENDIX C**

**Interconnection Details**

**Description of Large Generating Facility including Point of Interconnection**

The Large Generating Facility is a 215.5 MW wind power facility that will employ seventy (70) Vestas V112 3.075 MW Type 4 wind-turbine generators. Each of the seventy (70) units has a reactive power capability corresponding to a power factor range of 0.868 lagging to 0.933 leading (at the generator terminals) giving a gross plant reactive capability of +123.2 MVAR to -82.6 MVAR (sum of unit capabilities). The reactive power output of the Large Generating Facility at the Point of Interconnection will be limited to +/- 0.98 power factor.

The Large Generating Facility will interconnect to Transmission Owner's Willis-Duley #1 230 kV transmission line. The Point of Interconnection will be approximately 9.6 miles from the Willis Substation and 14.1 miles from the Duley Substation. The Large Generating Facility will be located in the Towns of Clinton and Ellenburg in Clinton County, New York. The Point of Interconnection is identified on Figure 1, in Appendix A.

The Large Generating Facility is connected via -eight 34.5kV collector circuits from the turbine fields to the Marble River Collection Substation. All circuits consist entirely of underground cables. Turbine Count per circuit:

1. Circuit One: 9 turbines.
2. Circuit Two: 8 turbines.
3. Circuit Three: 10 turbines.
4. Circuit Four: 10 turbines.
5. Circuit Five : 8 turbines
6. Circuit Six: 9 turbines
7. Circuit Seven: 10 turbines
8. Circuit Eight: 6 turbines

Underground circuits are solid dielectric 34.5kV power cable with concentric neutrals direct buried in cable trenches four feet below surface grade to the top of cable. The cable size used in the underground design includes: 1250 kCMIL, 1000 kCMIL, 750 kCMIL, 350 kCMIL, and 4/0. Fiber optic cables provide the communications medium between the wind farm and the Marble River Collection Substation. They are direct buried with the underground 34.5kV power cables for the underground installation.

Each turbine has a single three phase generator step up transformer located in the nacelle of the turbine. Each transformer is rated 3.45MVA (OA rating) with a Delta-Wye grounded connection with 34.5 kV/ 650 V rating. The transformer has a nominal impedance of 8%. Each transformer is also equipped with a NO-LOAD tap changer: +/- 2.5% and +/- 5% taps available (36,230 V; 35,360 V; 34,500 V; 22,460 V; 32,780V).

## **SERVICE AGREEMENT NO. 1774**

### **Developer Operating Requirements**

The Developer must comply with the Connecting Transmission Owner's operating instructions and requirements, including but not limited to Connecting Transmission Owners' Operation Coordination Agreement, as it may change from time to time. The Developer must comply with all applicable NYISO tariffs and procedures, as amended from time to time.

The Post-transition Period LVRT standard, as set forth in Appendix G, paragraph A.i to this LGIA, is applicable to the Developer's Large Generating Facility. For purposes of compliance with Appendix G, the Connecting Transmission Owner has determined that the Developer shall maintain the Large Generating Facility in service during a three-phase fault for 9 cycles.

**APPENDIX D**

**Security Arrangements Details**

Infrastructure security of New York State Transmission System equipment and operations and control hardware and software is essential to ensure day-to-day New York State Transmission System reliability and operational security. The Commission will expect the NYISO, all Connecting Transmission Owners, all Developers and all other Market Participants to comply with the recommendations offered by the President's Critical Infrastructure Protection Board and, eventually, best practice recommendations from the electric reliability authority. All public utilities will be expected to meet basic standards for system infrastructure and operational security, including physical, operational, and cyber-security practices.

All personnel working in Connecting Transmission Owner's facilities will require security background checks prior to entering and working in such facilities.

**APPENDIX E**

**Commercial Operation Date**

**[Date]**

New York Independent System Operator, Inc.  
Attn: Vice President, Operations  
3890 Carman Road  
Schenectady, NY 12303

Vice President of Transmission  
New York Power Authority  
Clark Energy Center  
6520 Glass Factory Road  
Marcy, NY 13403-2100

Re: \_\_\_\_\_ Large Generating Facility

Dear \_\_\_\_\_:

On **[Date]** **[Developer]** has completed Trial Operation of Unit No. \_\_\_\_\_. This letter confirms that **[Developer]** commenced Commercial Operation of Unit No. \_\_\_\_\_ at the Large Generating Facility, effective as of **[Date plus one day]**.

Thank you.

**[Signature]**

**[Developer Representative]**

**APPENDIX F**

**Addresses for Delivery of Notices and Billings**

**Notices:**

NYISO:

- (i) Before commercial operation of the Large Generating Facility:

New York Independent System Operator, Inc.  
Attention: Vice President, System and Resource Planning  
10 Krey Boulevard  
Rensselaer, NY 12144  
Phone: (518) 356-6000  
Fax: (518) 356-6118

- (ii) After commercial operation of the Large Generating Facility:

New York Independent System Operator, Inc.  
Attn: Vice President, Operations  
3890 Carman Road  
Schenectady, NY 12303  
Phone: (518) 356-6000  
Fax: (518) 356-6118

Connecting Transmission Owner:

Vice President of Transmission  
New York Power Authority  
Clark Energy Center  
6520 Glass Factory Road  
Marcy, NY 13403-2100

Developer:

General Counsel  
Marble River, LLC  
c/o Horizon Wind Energy LLC  
An EDP Company  
808 Travis, Suite 700  
Houston, TX 77002

## SERVICE AGREEMENT NO. 1774

### Billings and Payments:

#### Connecting Transmission Owner:

New York Power Authority  
Operating Fund c/o  
J.P. Morgan Chase, N.A.  
ABA No.: 021000021  
Account No.: 573-804206

#### Developer:

General Counsel  
Marble River, LLC  
c/o Horizon Wind Energy LLC  
An EDP Company  
808 Travis, Suite 700  
Houston, TX 77002

Alternative Forms of Delivery of Notices (telephone, facsimile or email):

#### NYISO:

- (i) Before commercial operation of the Large Generating Facility:

New York Independent System Operator, Inc.  
Attention: Vice President, System and Resource Planning  
10 Krey Boulevard  
Rensselaer, NY 12144  
Phone: (518) 356-6000  
Fax: (518) 356-6118

- (ii) After commercial operation of the Large Generating Facility:

New York Independent System Operator, Inc.  
Attn: Vice President, Operations  
3890 Carman Road  
Schenectady, NY 12303  
Phone: (518) 356-6000  
Fax: (518) 356-6118

**SERVICE AGREEMENT NO. 1774**

Connecting Transmission Owner:

Vice President of Transmission  
New York Power Authority  
Clark Energy Center  
6520 Glass Factory Road  
Marcy, NY 13403-2100

Developer:

General Counsel  
Marble River, LLC  
c/o Horizon Wind Energy LLC  
An EDP Company  
808 Travis, Suite 700  
Houston, TX 77002

**APPENDIX G**

**Interconnection Requirements for A Wind Generating Plant**

Appendix G sets forth requirements and provisions specific to a wind generating plant.

All other requirements of this LGIA continue to apply to wind generating plant interconnections.

**A. Technical Standards Applicable to a Wind Generating Plant**

**i. Low Voltage Ride-Through (LVRT) Capability**

A wind generating plant shall be able to remain online during voltage disturbances up to the time periods and associated voltage levels set forth in the standard below. The LVRT standard provides for a transition period standard and a post-transition period standard.

**Transition Period LVRT Standard**

The transition period standard applies to wind generating plants subject to FERC Order 661 that have either: (i) interconnection agreements signed and filed with the Commission, filed with the Commission in unexecuted form, finally executed as conforming agreements, or filed with the Commission as non-conforming agreements between January 1, 2006 and December 31, 2006, with a scheduled in-service date no later than December 31, 2007, or (ii) wind generating turbines subject to a wind turbine procurement contract executed prior to December 31, 2005, for delivery through 2007.

1. Wind generating plants are required to remain in-service during three-phase faults with normal clearing (which is a time period of approximately 4 – 9 cycles) and single line to ground faults with delayed clearing, and subsequent post-fault voltage recovery to prefault voltage unless clearing the fault effectively disconnects the generator from the system. The clearing time requirement for a three-phase fault will be specific to the wind generating plant substation location, as determined by and documented by the Connecting Transmission Owner for the

## SERVICE AGREEMENT NO. 1774

Transmission District to which the wind generating plant will be interconnected.

The maximum clearing time the wind generating plant shall be required to withstand for a three-phase fault shall be 9 cycles at a voltage as low as 0.15 p.u., as measured at the high side of the wind generating plant step-up transformer (i.e. the transformer that steps the voltage up to the transmission interconnection voltage or “GSU”), after which, if the fault remains following the location-specific normal clearing time for three-phase faults, the wind generating plant may disconnect from the transmission system.

2. This requirement does not apply to faults that would occur between the wind generator terminals and the high side of the GSU or to faults that would result in a voltage lower than 0.15 per unit on the high side of the GSU serving the facility.
3. Wind generating plants may be tripped after the fault period if this action is intended as part of a special protection system.
4. Wind generating plants may meet the LVRT requirements of this standard by the performance of the generators or by installing additional equipment (e.g., Static VAr Compensator, etc.) within the wind generating plant or by a combination of generator performance and additional equipment.
5. Existing individual generator units that are, or have been, interconnected to the network at the same location at the effective date of the Appendix G LVRT Standard are exempt from meeting the Appendix G LVRT Standard for the remaining life of the existing generation equipment. Existing individual generator units that are replaced are required to meet the Appendix G LVRT Standard.

**Post-transition Period LVRT Standard**

All wind generating plants subject to FERC Order No. 661 and not covered by the transition period described above must meet the following requirements:

1. Wind generating plants are required to remain in-service during three-phase faults with normal clearing (which is a time period of approximately 4 – 9 cycles) and single line to ground faults with delayed clearing, and subsequent post-fault voltage recovery to prefault voltage unless clearing the fault effectively disconnects the generator from the system. The clearing time requirement for a three-phase fault will be specific to the wind generating plant substation location, as determined by and documented by the Connecting Transmission Owner for the Transmission District to which the wind generating plant will be interconnected. The maximum clearing time the wind generating plant shall be required to withstand for a three-phase fault shall be 9 cycles after which, if the fault remains following the location-specific normal clearing time for three-phase faults, the wind generating plant may disconnect from the transmission system. A wind generating plant shall remain interconnected during such a fault on the transmission system for a voltage level as low as zero volts, as measured at the high voltage side of the wind GSU.
2. This requirement does not apply to faults that would occur between the wind generator terminals and the high side of the GSU.
3. Wind generating plants may be tripped after the fault period if this action is intended as part of a special protection system.
4. Wind generating plants may meet the LVRT requirements of this standard by the performance of the generators or by installing additional equipment (e.g., Static

VAR Compensator) within the wind generating plant or by a combination of generator performance and additional equipment.

5. Existing individual generator units that are, or have been, interconnected to the network at the same location at the effective date of the Appendix G LVRT Standard are exempt from meeting the Appendix G LVRT Standard for the remaining life of the existing generation equipment. Existing individual generator units that are replaced are required to meet the Appendix G LVRT Standard.

**ii. Power Factor Design Criteria (Reactive Power)**

A wind generating plant shall maintain a power factor within the range of 0.95 leading to 0.95 lagging, measured at the Point of Interconnection as defined in this LGIA, if the ISO's System Reliability Impact Study shows that such a requirement is necessary to ensure safety or reliability.

The power factor range standard can be met using, for example without limitation, power electronics designed to supply this level of reactive capability (taking into account any limitations due to voltage level, real power output, etc.) or fixed and switched capacitors if agreed to by the Connecting Transmission Owner for the Transmission District to which the wind generating plant will be interconnected, or a combination of the two. The Developer shall not disable power factor equipment while the wind plant is in operation. Wind plants shall also be able to provide sufficient dynamic voltage support in lieu of the power system stabilizer and automatic voltage regulation at the generator excitation system if the System Reliability Impact Study shows this to be required for system safety or reliability.

**iii. Supervisory Control and Data Acquisition (SCADA) Capability**

The wind plant shall provide SCADA capability to transmit data and receive instructions from the ISO and/or the Connecting Transmission Owner for the Transmission District to which the wind generating plant will be interconnected, as applicable, to protect system reliability. The Connecting Transmission Owner for the Transmission District to which the wind generating plant will be interconnected and the wind plant Developer shall determine what SCADA information is essential for the proposed wind plant, taking into account the size of the plant and its characteristics, location, and importance in maintaining generation resource adequacy and transmission system reliability in its area.

**APPENDIX H**

**Invoicing and Payment**

**A. General**

SASUF and Attachment Facilities will be invoiced under the standard invoicing provisions of the LGIA. All Common SUF costs have been paid in satisfaction to NYPA by Developer for NYPA-related work.

**1. Detail Required**

All invoices submitted under this Agreement shall state the month to which the invoice applies and fully describe the services and equipment provided. All invoices will indicate if and to what extent costs being invoiced are asserted as having been incurred as a result of an Uncontrollable Cost Event (as such term is defined in Appendix B). All invoices for construction and equipment costs shall be prepared using the AIA G702-1992 form.

**2. Payment**

Invoices will be due and payable within the period of time specified in each subsection below unless otherwise mutually agreed in writing. All payments shall be made in the form of immediately available funds by wire transfer to the account specified in Appendix F of this Interconnection Agreement or otherwise provided by the parties in writing.

**3. Late Payment**

All amounts due and not paid within the time period specified following the date of receipt shall be subject to interest calculated in accord with the methodology set forth in FERC's regulations at 18 CFR § 35.19a(a)(2)(iii).

**B. Invoices/Payment for Common System Upgrade Facilities ("Common SUFs")**

**1. Clinton and Ellenburg Monthly Invoice**

(a) By the first Calendar Day of each month, Noble Clinton Windpark I, LLC ("Clinton") and Noble Ellenburg Windpark, LLC ("Ellenburg" and together with Clinton, "Clinton and Ellenburg") will provide to NYPA an invoice for all work performed by Clinton and Ellenburg for SUF work for the previous month. Each invoice will separately identify and itemize all work performed in connection with the Common SUFs and any non-Common SUFs (collectively, the "SUFs"). These invoices will be used by NYPA in the calculation of the total SUF costs for the purposes of allocating costs among Clinton and Ellenburg, Noble Altona Windpark, LLC ("Altona") and Marble River, LLC ("Marble River") (each, individually, referred to as a "Project" and all four collectively referred to as the "Projects").

- (b) By the first Calendar Day of each month, Clinton and Ellenburg will provide a copy of such invoice to Marble River and Altona.

**2. NYPA Monthly Invoices**

- a. Within thirty (30) Calendar Days of its receipt of Clinton and Ellenburg's monthly invoice, NYPA will prepare and send invoices to the Projects which will include:
  - i. Each Project's respective share of NYPA's work performed for Common SUFs.
  - ii. Each Project's respective share of Clinton's and Ellenburg's work performed for Common SUFs.
  - iii. NYPA's work performed for Attachment Facilities and/or non-Common SUFs for each individual Project.
- b. All NYPA invoices are subject to the following cost allocation:
  - i. NYPA's invoices shall allocate costs related to any non-Common SUFs to the appropriate Project. The non-Common SUFs required for both the Clinton Windfield and Ellenburg Windfield shall be allocated as follows: Clinton 50% and Ellenburg 50%.
  - ii. NYPA's invoices shall allocate costs related to the Common SUFs among the Projects using the allocation percentage determined pursuant to Attachment S of the NYISO OATT ("Attachment S"), except as provided in subsection (b)(ii) below. The allocation percentages, as set forth in the Facilities Study for Class 2006: Part 2 - System Upgrade Facilities, are as follows: Clinton 20%; Ellenburg 20%; Altona 20%; and Marble River 40%.
  - iii. In the event that excess cost is incurred to complete the Common SUFs as a result of an Uncontrollable Cost Event (as such term is defined in Appendix B) as set forth in subsections (i), (ii) or (iii) of the definition of Uncontrollable Cost Event, then such costs will be allocated among Ellenburg, Clinton, Altona and Marble River pursuant to the allocation percentages set forth in Section B.2(b)(ii) above, and in no event shall such excess costs be the responsibility of NYPA.

In the event that excess cost is incurred to complete the Common SUFs as a result of an Uncontrollable Cost Event (as such term is defined in Appendix B) as set forth in subsections (iv) or (v) of the definition of Uncontrollable Cost Event, then: (A) to the extent that NYPA is responsible for such costs pursuant to the procedures set forth in Attachment S of the NYISO OATT, as such responsibility is determined in accordance with the next paragraph, such costs will be allocated to NYPA; (B) to the extent that NYPA is not responsible for such costs pursuant to the procedures set forth in Attachment S of the NYISO OATT and Marble River is the Transferee (as such term is defined in Appendix B), such costs will be

allocated among Ellenburg, Clinton, Altona and Marble River pursuant to the allocation percentages set forth in Section B.2(b)(i) above; and (C) to the extent that NYPA is not responsible for such costs pursuant to the procedures set forth in Attachment S of the NYISO OATT and neither NYPA nor Marble River is the Transferee (as such term is defined in Appendix B), such costs will be allocated equally among Ellenburg, Clinton and Altona.

The Parties agree that in determining the extent of NYPA's responsibility (if any) for costs pursuant to the procedures set forth in Attachment S of the NYISO OATT, only NYPA's actions (or inaction) shall be considered; NYPA shall not be responsible for the actions (or inaction) of any Transferee (as such term is defined in Appendix B).

- c. Each Project is required to pay its respective invoice(s) to NYPA within thirty (30) Calendar Days of receipt of such invoice(s).
  - i. Clinton and Ellenburg will pay to NYPA their respective allocated shares of NYPA's work performed for Common and non-Common SUFs as well as Clinton and Ellenburg Connecting Transmission Owner Attachment Facilities; provided, however, that, together with Altona, Clinton and Ellenburg will be required to pay all of NYPA's costs for Phase I Common SUF work.
  - ii. In lieu of payment by Altona, Altona may provide NYPA certification from Clinton and Ellenburg that Altona has paid to Clinton and Ellenburg its share of the Clinton and Ellenburg work performed for the Common SUFs.
  - iii. Altona will be required to pay to NYPA its allocated shares for NYPA's work performed for Common SUFs and Altona Connecting Transmission Owner Attachment Facilities; provided, however, that, together with Clinton and Ellenburg, Altona will be required to pay all of NYPA's costs for Phase I Common SUF work.
  - iv. Marble River will be required to pay to NYPA its allocated share for NYPA's work performed for Common SUFs, Clinton's and Ellenburg's work performed for Common SUFs, NYPA's work performed for Marble River Connecting Transmission Owner Attachment Facilities and NYPA's work performed for Marble River non-Common SUFs, if any; provided, however, that Marble River shall not be required to pay for NYPA's costs for Phase I SUF work.
- d. NYPA will pay to Clinton and Ellenburg the monies received from Marble River under 2(b)(iv) for Clinton and Ellenburg's Common SUF work within fifteen (15) Calendar Days of receiving payment from Marble River.
  - i. In the event that Clinton and Ellenburg do not receive payment from NYPA within fifteen (15) Calendar Days of the date which such payment is due from

Marble River (and, to the extent applicable, Altona), and NYPA has not received such payment from Marble River (and, to the extent applicable, Altona), then Clinton and Ellenburg may request NYPA to pursue payment as set forth in subsection 2(d)(ii) below.

- ii. NYPA agrees to use reasonable efforts to obtain payment (less any disputed amounts) from Marble River (and, to the extent applicable, Altona), including exercising such available rights as NYPA may have against Marble River (and, to the extent applicable, Altona), including drawing on SUF-related letters of credit or other forms of security, in an amount not to exceed Marble River's (and, to the extent applicable, Altona's) share of any undisputed invoice. NYPA must pursue reasonable efforts to resolve any disputes with Marble River in the event that Marble River has withheld any disputed portion of any payment.
- iii. In no event shall NYPA be obligated to pay Clinton and Ellenburg for SUF work owed by Marble River or Altona unless NYPA has (x) received payment for such work from Marble River or Altona, (y) drawn from the applicable letter(s) of credit to pay for such work or (z) failed to use reasonable efforts to obtain payment as described in 2(d)(ii) above.

### **3. Final Invoices**

- a. The procedures set forth above for monthly invoices in Sections B.1 and B.2 of this Appendix H shall apply to the final invoices.
- b. Within six (6) months after NYPA's acceptance and approval of the Common SUFs, Clinton and Ellenburg shall provide to NYPA their final invoice, which shall include all costs of Clinton and Ellenburg's work performed for Common SUFs that have not been invoiced pursuant to a monthly invoice.
- c. Within thirty (30) calendar days of receipt of such invoice from Clinton and Ellenburg, NYPA will send final invoices to Altona and Marble River, reflecting their respective share of the final cost of (1) NYPA's and Clinton and Ellenburg's work performed for Common and non-Common SUFs and (2) NYPA's work for Attachment Facilities.

### **4. Audit Rights**

NYPA may exercise its rights (under Article 25.3 of the Interconnection Agreement) to audit Clinton's and Ellenburg's accounts and records for the benefit of Marble River and/or Altona related to (a) the design engineering, procurement and construction of Common SUFs and (b) the calculation of invoiced amounts. Audit rights granted hereunder are not intended to limit or supersede audit rights NYPA, Marble River and/or Altona may otherwise have elsewhere in this Interconnection Agreement or under other agreements.