



OpenWay® Riva™ CENTRON® Singlephase Energy Only Electricity Meter

Technical Reference Guide

Identification

OpenWay® Riva™ CENTRON® Singlephase Electricity Meter Technical Reference Guide
OpenWay Riva CENTRON

Copyright

© 2016 Itron, Inc. All rights reserved.

Confidentiality Notice

The information contained herein is proprietary and confidential and is being provided subject to the condition that (i) it be held in confidence except to the extent required otherwise by law and (ii) it will be used only for the purposes described herein. Any third party that is given access to this information shall be similarly bound in writing.

Trademark Notice

Itron is a registered trademark of Itron, Inc.

All other product names and logos in this documentation are used for identification purposes only and may be trademarks or registered trademarks of their respective companies.

Suggestions

For more information about Itron or Itron products, see www.itron.com.

If you have questions or comments about the software or hardware product, contact Itron Technical Support Services.

Contact

- Email: support@itron.com
- Internet: support.itron.com
- Telephone Itron Technical Support North America: 1-877-487-6602

For technical support contact information by region, go to www.itron.com and select your country and language.

FCC Compliance

FCC Part 15, Class B

This equipment has been tested and found to comply with the limits for a Class B digital device, pursuant to Part 15 of the FCC Rules. These limits are designed to provide reasonable protection against harmful interference in a residential installation. This equipment generates, uses and can radiate radio frequency energy and, if not installed and used in accordance with the instructions, may cause harmful interference to radio communications. However, there is no guarantee that interference will not occur in a particular installation. If this equipment does cause harmful interference to radio or television reception, which can be determined by turning the equipment off and on, the user is encouraged to try to correct the interference by one or more of the following measures:

- Reorient or relocate the receiving antenna.
- Increase the separation between the equipment and receiver.
- Connect the equipment into an outlet on a circuit different from that to which the receiver is connected.
- Consult the dealer or an experienced radio/TV technician for help.



Changes or modifications to this device not expressly approved by Itron, Inc. could void the user's authority to operate the equipment.

Innovation, Science and Economic Development Canada (ISED)

This Class B digital apparatus meets all requirements of the Canadian Interference Causing Equipment Regulations. Operation is subject to the following two conditions: (1) this device may not cause harmful interference, and (2) this device must accept any interference received, including interference that may cause undesired operation.

Cet appareillage numérique de la classe B répond à la norme Canadienne sur le matériel brouilleur. L'opération est sujette aux deux conditions suivantes: (1) ce dispositif ne peut pas causer d'interférence nocive, et (2) ce dispositif doit accepter n'importe quelle interférence reçue, y compris les interférences pouvant entraîner un fonctionnement indésirable.

Under Innovation, Science and Economic Development Canada regulations, this radio transmitter may only operate using an antenna of a type and maximum (or lesser) gain approved for the transmitter by Innovation, Science and Economic Development Canada. To reduce potential radio interference to other users, the antenna type and its gain should be so chosen that the equivalent isotropically radiated power (e.i.r.p.) is not more than that necessary for successful communication.

Conformément à la réglementation d'Industrie Canada, le présent émetteur radio peut fonctionner avec une antenne d'un type et d'un gain maximal (ou inférieur) approuvé pour l'émetteur par Industrie Canada. Dans le but de réduire les risques de brouillage radioélectrique à l'intention des autres utilisateurs, il faut choisir le type d'antenne et son gain de sorte que la puissance isotrope rayonnée équivalente (p.i.r.e.) ne dépasse pas l'intensité nécessaire à l'établissement d'une communication satisfaisante.

RF Exposure (FCC/ISED)

The antenna(s) used for this transmitter must be installed to provide a separation distance of at least 20 cm from all persons and must not be co-located or operating in conjunction with any other antenna or transmitter. End-users and installers must be provided with antenna installation instructions and transmitter operating conditions for satisfying RF exposure compliance.

Under ISED regulations, this radio transmitter may only operate using an antenna of a type and maximum (or lesser) gain approved for the transmitter by ISED . To reduce potential radio interference to other users, the antenna type and its gain should be so chosen that the equivalent isotropically radiated power (e.i.r.p.) is not more than that necessary for successful communication.

This radio transmitter (identify the device by certification number, or model number if Category II) has been approved by ISED to operate with the antenna types listed below with the maximum permissible gain and required antenna impedance for each antenna type indicated. Antenna types not included in this list, having a gain greater than the maximum gain indicated for that type, are strictly prohibited for use with this device.

Professional Installation

These antennas are intended for professional installation by the integrator. The OEM integrator is still responsible for the FCC compliance requirement of the end product, which integrates this antenna.

Modification and Repairs

To ensure FCC compliance and system performance, this device, antenna and/or coaxial assembly shall not be changed or modified without the express written approval of Itron. Any unauthorized modification will void the user's authority to operate the equipment.



This device contains no user serviceable parts. Attempts to repair this device by unauthorized personnel may subject the person to shock hazard if removal of protected covers is attempted. Unauthorized repair will void the warranty and/or maintenance contract with your company.

Factory Repair of Meters

Itron recommends that all repairs be performed at the factory. Certain repairs may be performed by the user; however, unauthorized repairs will cause any existing warranty to be void.

Repair of Meters Under Warranty

If the meter is under warranty and has failed due to components or workmanship, then Itron, Inc. will repair the meter at no charge. A return authorization number must be obtained before the equipment can be sent back to the factory. Contact your Itron Sales Representative for assistance.

Repair of Meters Not Under Warranty

The same procedure as above applies. Itron will charge for the necessary repairs based on the failure.

Service Return Address

Itron, Inc.
Customer Repair Department
313 North Highway 11 Dock C
West Union, SC 29696

Recycling Information

The product you have purchased may contain a battery (or batteries), circuit boards, and switches. The batteries are recyclable. At the end of the product's useful life, under various state and local laws, it may be illegal to dispose of certain components into the municipal waste system. Check with your local solid waste officials for details about recycling options or proper disposal.

Although polycarbonate is not a commonly recycled plastic, the recycling number for the polycarbonate inner and outer cover is seven (7).

Contents

FCC Compliance	iii
FCC Part 15, Class B.....	iii
Innovation, Science and Economic Development Canada (ISED).....	iii
RF Exposure (FCC/ISED).....	iv
Professional Installation.....	iv
Modification and Repairs.....	iv
Factory Repair of Meters.....	v
Repair of Meters Under Warranty.....	v
Repair of Meters Not Under Warranty.....	v
Service Return Address.....	v
Recycling Information.....	v
OpenWay® Riva™ Overview	1
IPv6 Mesh.....	1
Adaptive Communications Technology (ACT).....	1
CGR ACT Module (CAM).....	2
OpenWay Operations Center (OWOC).....	3
Meter Description	5
Meter Physical Description.....	6
Meter Components.....	7
Standard Nameplate.....	8
Installation	9
Safety.....	9
Unpacking and Inspection.....	9
Battery.....	10
Selecting a Site.....	10
Specifications	11
Electrical.....	11
Radio Specifications.....	11
Operating Environment.....	11
Storage.....	11
Burden Data.....	11
Technical Data.....	12
Shipping Weights.....	12
Metrology	13
Voltage and Current Measurement.....	14
Sampling.....	14

Watt-hour Measurement.....	15
Volt-ampere-hour (VAh) Measurement	15
Service Switch	16
Load Side Voltage Detection	17
Switch Behavior	18
Connect.....	18
Disconnect	18

Metering Applications 19

Meter Programming.....	19
OWOC/FDM Tools Programming.....	19
Registers	20
Energy Registers.....	20
Energy Data Display Items	20
Self-Read Registers	22
End-of-Billing Registers	23
Instantaneous Registers	23
Instantaneous Data Display Items	23
Information Registers	23
Enhanced Security	23
Key Elements	24
Signed Authorization	24
Tamper Detection.....	25
Display Items	25
Informational Data Display Items	26
Time Synchronization.....	26
Time of Use (TOU)	26
Time of Use Schedules	27
Calendar Schedule	27
Rates.....	27
Daily Patterns	27
Day Types.....	27
Holidays	27
Seasonal Schedules	27
TOU Registers	27
Current Season Registers	27
TOU Operation.....	28
Rate Annunciators and Active Rate Indicators	28
Season Change	28
Load Profile	28
Load Profile Specifications.....	28
Interval Lengths	28
Power Outage.....	28
Channel Configuration	29
Load Profile Storage	29
Recording Duration	30
Voltage Monitoring	30
Nominal Voltage.....	30
VM Threshold Monitoring.....	30

Voltage Profiling	30
Voltage Profile Specifications	31
Capacity (Riva Singlephase).....	31
Remote Disconnect/Reconnect.....	31
Event (History) Log.....	31
Metering Events	31
Self Read Events	32
Voltage Events	32
Current Events	32
Power Outages	32
Firmware Download Events	32
Tamper Events.....	33
Connect/Disconnect Events.....	33
System Events	33
Security Events	34
TOU Events.....	34

Testing, Troubleshooting, and Maintenance..... 35

Testing.....	35
Recommended Energy Testing Procedures	35
Visual Indicators.....	35
Annunciators	35
Load Indication/Direction Annunciator	35
Troubleshooting.....	35
Error Modes	35
Diagnostic Error Mode	36
Error Mode.....	36
Network Troubleshooting	36
Communications Media	36
Number of Hops.....	37
Link Quality	37
Maintenance.....	37
Preventive Maintenance	37
Corrective Maintenance	37

OpenWay® Riva™ Overview

The OpenWay Riva solution delivers scalable and inter operable headend software, a robust and secure IPv6 network comprising RF Mesh, PLC Mesh, and cellular endpoints and an integrated home area network designed to provide redundant two-way communications. Adaptive Communications Technology (ACT) enables each endpoint to communicate using either RF or PLC links with dynamic selection of the optimal path and modulation rates.

IPv6 Mesh

End-to-end implementation of the Cisco IPv6 reference design for field area networks (FAN) makes the OpenWay Riva solution capable of incorporating multiple networks, applications, and devices within a single communications architecture. The use of IPv6 standard protocols enables common application layer services over various wired and wireless communication technologies.

Two-way communications from the CGRs to the smart meters, HAN devices, DA devices and other smart grid devices are enabled through Itron's new and patented Adaptive Communications Technology (ACT). ACT combines both IPv6 RF and PLC communications technologies into a single, integrated communications module that delivers assured network connectivity at the highest possible speed.

Adaptive Communications Technology (ACT)

Adaptive Communications Technology (ACT) enables each endpoint to communicate using either RF or PLC links with dynamic selection of the optimal path and modulation rates. Intelligence in the ACT module chooses the communication link type and modulation scheme that support the best possible data rate. High data rates deliver the required throughput for a multi-application network while long range modes ensure devices on the periphery of the coverage area can join the network. This is done automatically in real time by the ACT modules without any need for pre-programming or path hard-coding.

CGR ACT Module (CAM)

The OpenWay Riva CGR ACT Module (CAM) resides in the Cisco CGR and acts as the root-node within the network, routing packets and information from meters or grid devices between the ACT network and the headend. The CAM supports adaptive communications which allows meters and grid devices to interact with each other while dynamically switching between Radio Frequency (RF) and Power Line Carrier (PLC) to ensure the fastest and most reliable path. The optional ACT Coupler Unit adds support for 3-phase coupling of PLC signals to ensure robust PLC communications to all end points on the network in select environments (High rise buildings, densely populated cities, etc.).

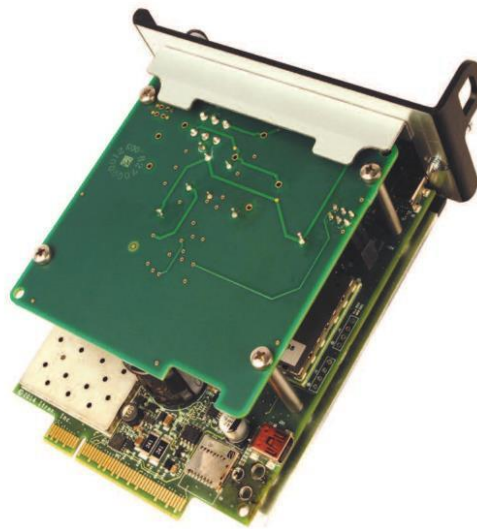

The OpenWay Riva ACT module for the CGR is installed in an available expansion slot within the CGR and serves as the network-level communications component within the Adaptive Communications Technology based OpenWay solution. With adaptive communication capabilities, deployment of network infrastructure is easier, faster and less costly. It also reduces the amount of time and effort needed for upfront network design and propagation studies. With these new capabilities, meters and other grid devices can process, analyze, communicate and react in real-time, intelligently switching communication modes between PLC and RF to provide optimal network performance with assured connectivity.

This intelligence at the meter also provides a platform for new, real-time analytic applications at the device and field area network level. By enabling each connected device to intelligently find and utilize the best, fastest and most reliable communications path – whether RF or PLC – and choosing among multiple modulation schemes in every circumstance at every level of the network, Adaptive Communications Technology can eliminate many of the costly compromises and performance trade-offs that utilities continually make in specifying a single communication technology to address the full diversity of their service territories and use case requirements. And because it was designed on a global technology platform using software defined communications technology, ACT is also readily adaptable to support the specific communication standards and protocols in use in countries and regions throughout the world.

OpenWay Operations Center (OWOC)

The OpenWay Operations Center (OWOC) acts as the centralized hub between the metering system and utility processes such as meter data management, billing, outage management, distribution automation, and load control. It manages high-volume, secure advanced metering, disconnect/connect, and demand response requests. The OWOC also manages device configuration attributes and firmware downloads directly to the endpoints.

The OWOC delivers a collection of AMI services that address a wide range of advanced metering use cases. The OWOC manages meters through secure, two-way communications using standard meter application protocols, while most upstream communications are managed through web services. The primary functions supported by the OWOC are:

- Meter Provisioning and Registration
- Meter Data Collection
- Interactive Read
- Disconnect / Reconnect Service Orders
- Event and Exception Notifications
- Outage Notification and Restoration Verification
- Meter Configurations
- Meter Firmware
- Read Rate Reporting
- Demand Response and Load Control
- HAN Communication Management
- Security Key Management for AMI Services
- Data Distribution and System Integration
- Integration to MDMS

CHAPTER 2

Meter Description

This section provides information on the design, construction, and operation of the OpenWay® Riva™ CENTRON® Electricity Meter.

The meter consists of three major components

- Power board containing the measurement device (metrology board)
- Mother board with built in communications module
- Outer cover for the meter

The meter is constructed using a polycarbonate resin material to provide enhanced weather protection for the internal components. The meter is securely sealed to prevent water, dust, and pest infiltration. These seals also serve as a deterrent for tamper activities.

OpenWay Riva CENTRON features an innovative multimedia IPv6 network that uses both Radio Frequency (RF) and Power Line Carrier (PLC) links within a mesh to route messages and data between standards-based smart meters and the head-end system.

The communication module enables utilities to deploy the network without specifically planning for segregation of RF and PLC environments. Intelligence in the communication module chooses the communication link quality and modulation scheme that support the best possible data rate. Data rates of up to 600Kbps are achievable by this multimedia mesh. This is done automatically in real-time by the modules without any need for pre-programming or path hard-coding. The communication modules create their own multi-hop environment using the best available physical path for communication where the routing is managed by standardized Internet Engineering Task Force (IETF) routing protocols that are independent of the physical link.

Meter Physical Description

The OpenWay CENTRON Riva Electricity meter features a support frame within the meter base. The support frame holds the circuit boards that provide the power, metrology, and metering applications. The base, support frame, and outer covers are polycarbonate.



Meter Components



Illustration Callout #	Field	Notes
1	ACT Adapter Board	
2	ACT Communications Board	
3	Board to Board Connector	Connects adapter board to the communications board
4	Service Switch Connector	
5	Support Frame	
6	Metrology Board	

Standard Nameplate

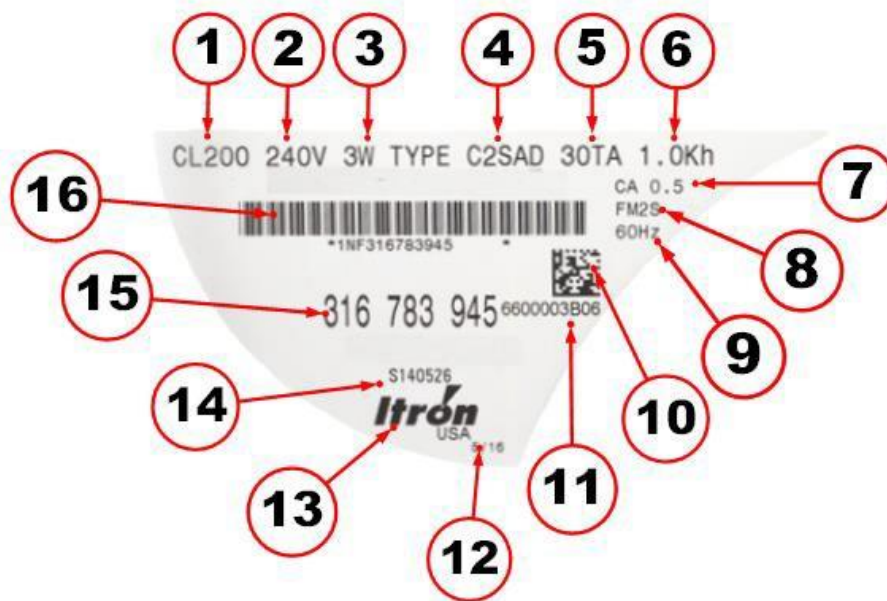

Illustration Callout #	Field	Notes
1	Meter Class	
2	Voltage	
3	Number of Wires	
4	Type Code	
5	Test Amps (current rating)	
6	Kh	Kh = ___ Wh/P
7	CA	Class Accuracy
8	Meter Form	
9	Frequency	
10	Itron 2D System Title Barcode	Used for Wi-Fi login
11	Itron Human Readable System Title	Used for Wi-Fi login
12	Date of Manufacture	Four digits - month/year
13	Itron Logo	
14	Customer Part Number	
15	Serial Number	
16	Meter Barcode	

Installation

Safety

Meter installation must be compliant with the generally accepted technical rules for the installation of electrical and telecommunication equipment valid in your country.

- Install the meter in accordance with the voltage and current specifications printed on the front panel and the wire and environmental specifications given in the installation information.
- Do not install the meter if it is obviously damaged.
- Do not install the meter if it has been dropped or otherwise subjected to significant impact even if no damage can be seen.
- The meter measuring and auxiliary circuits must be galvanically isolated.
- All voltage paths (measurement and auxiliary) must be fused.
- Do not use any meter functions or features for primary protection purposes.
- Do not install the meter where failure of the device could cause death, injury or release sufficient energy to start a fire.
- Following installation, ensure that the meter terminal covers are correctly fitted and sealed to prevent user access.

Unpacking and Inspection



Be sure you are working in a static-free environment; electrostatic discharge (ESD) can damage meter components.

Upon receipt:

- Check the condition of the packaging to ensure there was no damage during shipment.
- Verify that the packaging label matches the order.
- Inspect for obvious damage to the cover, base, and meter assembly.
- Compare the meter and register nameplates to the record card and invoice. Verify the type, class, voltage, form number, and other pertinent data.
- Verify that the Itron meter seals are in place.

As with all precision electronic instruments, the meter should be handled with care. Follow these precautions when handling the meter:

- Avoid damaging the meter base, cover, reset mechanism (if supplied), and optical connector (if supplied).
- When handling modules, grip the circuit board by its edges. Do not touch the liquid crystal display.
- Save the original packing materials.

Battery

The OpenWay Riva CENTRON meter contains a battery that powers the clock circuit during a power outage. The battery is permanently soldered to the module and is expected to last the life of the meter.



The product you have purchased contains a recyclable battery. At the end of its useful life, under various state and local laws, it may be illegal to dispose of this battery into the municipal waste stream. Check with your local area solid waste officials for details about recycling options or proper disposal.

Selecting a Site

The meter is designed and manufactured to be installed in an environment with an operating temperature range between -40°C and $+85^{\circ}\text{C}$ (-40°F to $+185^{\circ}\text{F}$). Operation in moderate temperatures increases reliability and product life.

CHAPTER 4

Specifications

Electrical

Voltage Rating	120V, 240V
Operating Voltage	± 20% (60Hz)
Frequency	60 Hz
Operating Range	± 3 Hz
Battery Type:	TADIRAN type 4902/PT
Operating Range:	3.6 V nominal; 3.4 V - 3.8 V

Radio Specifications

Output Power	500mW - 1 W
Frequency Ranges	902 - 928 MHz 870 - 876 MHz

Operating Environment

Temperature	-40°C to +85°C (-40°F to +185°F)
Humidity	0% to 95% non-condensing
Accuracy	± 0.5% @ unity power factor
Transient/Surge Suppression`	ANSI C62.45 - 2002; IEC 61000-4-4

Storage

Store the meter in a clean, dry (Relative Humidity < 50%) environment between -40°C to +85°C (-40°F to +185°F). Avoid prolonged storage (more than one year) at temperatures above +70°C (+158°F). Store the meter in the original packing material.

Burden Data

Meter Form	Watt Loss	VA Loss
2S	3.2	7.5

Technical Data

Meets applicable standards:

- ANSI C12.1 - 2008 (American National Standard for Electricity Meters - Code for Electricity Metering)
- ANSI C12.20 - 2010 (American National Standard for Electricity Meters - 0.2 and 0.5 Accuracy Classes)
- ANSI/IEEE C62.45 - 2002 (Guide to Surge Testing on Low-Voltage AC Power Circuits)
- ANSI MH 10.8 - 2005 Specification for Bar Code
- ANSI ASQZ 1.4 - 2008 Sampling Procedures and Tables for Inspection by Attributes
- IEC 61000-4-2 2008
- IEC 61000-4-4 2012
- IEEE C37.90.1 - 2004 SWC Surge Testing
- IEEE C65.42 2002 Recommended Practice on Surge Testing for Equipment Connected to Low Voltage (1000V or less) AC Power Circuits
- NEMA SG-AMI 1 - 2009 Requirements for AMI Meter Upgradeability

Shipping Weights

The following weight measurements are shown in kilograms and (pounds).

Packaging	Weight kgs(lbs)
4 Meters and Carton	11.0 (4.98951)
96 Meter Pallets	299.0 (135.624)

Metrology

The OpenWay Riva CENTRON meter uses the Hall Effect to measure metered current and voltage dividers to measure metered voltage as indicated in block diagram below.

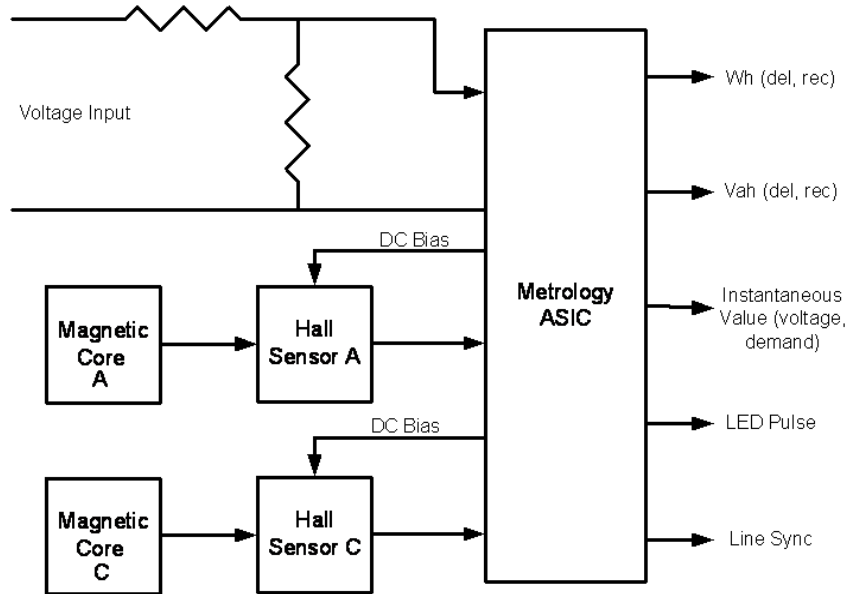

The metrology performs the direct sampling of the voltage and current waveforms and the raw processing of these samples to compute all the energy quantities. Low level signals proportional to the service voltages and currents are connected to the analog inputs of the Application Specific Integrated Circuit (ASIC). The ASIC individually samples the signals and sends the digital results to the compute engine in the ASIC 4,096 times per second. The compute engine takes these samples, applies precision calibration corrections and computes all the quantities required for the specific meter configuration.

All energy values are stored in the metrology and passed to the register via the Board-to-Board (B2B) connector using Itron protocol BLURT messages. The BLURT message contains: Wh d, Wh r, VAh d, VAh r, instantaneous voltage and status information.

Voltage and Current Measurement

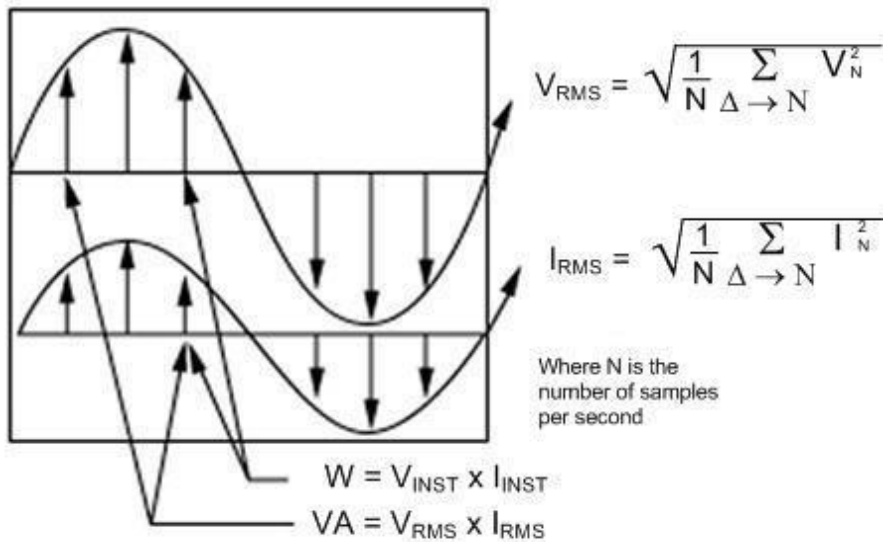

Sampling

The analog-to-digital converter samples each phase voltage and current signal (independent of the line frequency) and sends the digital values immediately to the ASIC. Each time a new set of digital samples is received by the ASIC, it calculates all of the metrological quantities.

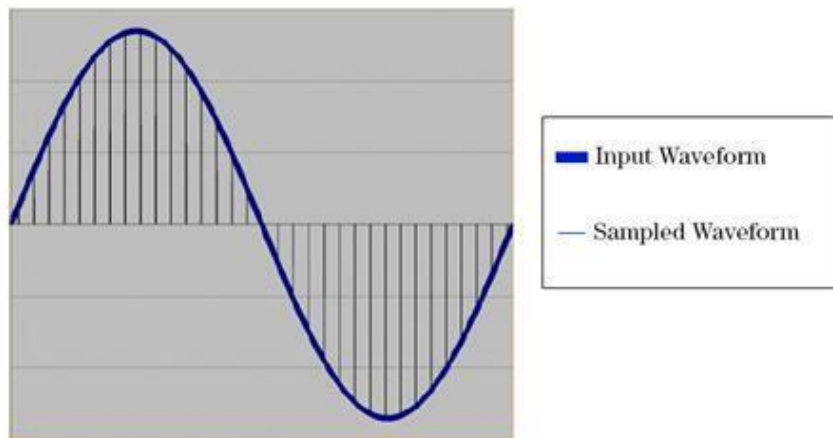

At this sampling rate (4096 times per second), harmonics to the 15th are measured. The high rate of the sampling enables the OpenWay Riva CENTRON meter to measure energy quantities accurately under high harmonic distortion conditions. The sampling continues uninterrupted as long as the meter is powered up. All other processing is done in the background between samples. From the continuous train of digital samples on two channels, voltage, active energy, and apparent energy quantities are computed.

Watt-hour Measurement

Watt-hours are measured by multiplying the instantaneous value of the voltage on each phase times the instantaneous value of the current on the same phase.

The resulting values are added to the Wh accumulator. The meter can be configured to register watt-hours either in the delivered quadrants only, or under bidirectional measurement, in the delivered and received quadrants. When only delivered watt-hours are measured, any negative watt-hour value is ignored. This has the same effect as a detent mechanism on an induction watt-hour meter.

When delivered and received watt-hours are measured, there will be one register for each quantity available: Wh delivered and Wh received, as well as two combined values at the register: Wh net and Wh uni.

Volt-ampere-hour (VAh) Measurement

The OpenWay Riva CENTRON meter measures either vectorial or RMS volt-amperes using arithmetic phase summation. The arithmetic method of measurement ensures that the resulting VAh value contains as much of the harmonic information as possible.

Volt-ampere values are calculated by multiplying the RMS voltage value times the coincident RMS current value.

The voltage and current values from each phase are squared and then stored in their respective accumulators. At the end of one second, each accumulator contains the sums of the square of the voltages or currents for each phase. The contents of these accumulators are passed to the consumption routine where they are averaged (divided by the sample count) and the square root is taken, yielding the RMS voltage and RMS current for each phase.

The RMS voltage and the RMS current for each phase are multiplied together once per second to establish a VA value for each phase. These values are scaled and corrected.

The total VA hour value is calculated by adding the VA-second quantities for each phase and dividing the total by 3600. This value is added to the appropriate register. If the harmonics on the voltage waveform differ from the harmonics on the current waveform, then the harmonic energies will fall out of the watt-hour calculation, but they will not fall out of the VA Arithmetic measurement.

The VA vectorial and VA arithmetic measurements will also differ when there is imbalanced power. Imbalanced power is generated when the phases of the service are not in balance with one another.

Service Switch

In forms 1S, 2S CL200, and 12S Network, the meter can contain a physical switch in the base that allows for remote, fast response disconnect and reconnect of the customer load to and from the service.

Upon restart after register firmware activation, the meter determines if the prior firmware version in the meter supported service limiting. If it did not, service limiting will be set to a default, disabled configuration.

The service switch is housed within the black plastic meter base shown in the figure below:

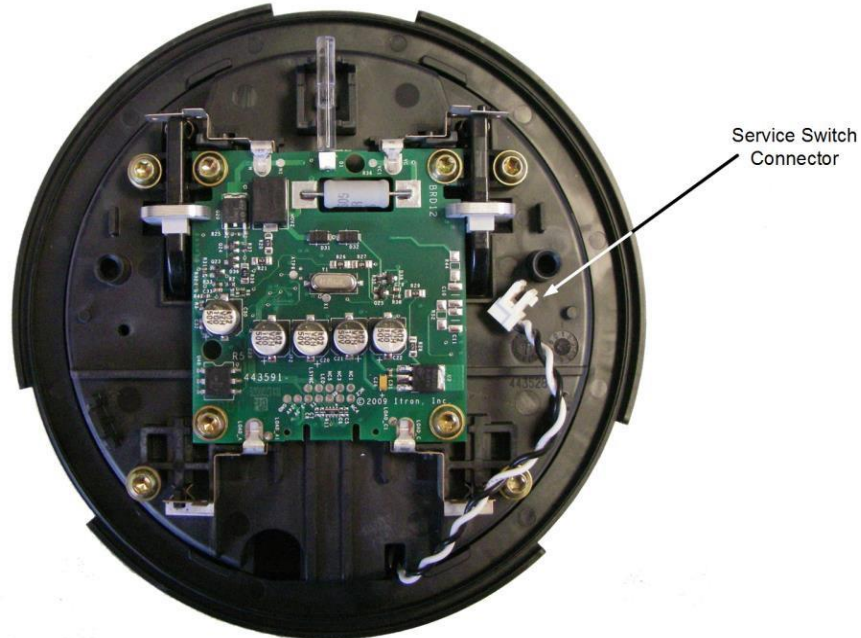

Upon installation of the meter, the default state of the switch is closed or connected. A meter that has been remotely disconnected remains energized and continues to monitor and record consumption (zero consumption for each interval).

The switch operates across the entire range of operational conditions for which the meter is rated to function. 30,000 operation cycles are possible at 240V, 0A load, and approximately 5,000 cycles are possible at a full 240V, 200A load. Mechanically, all disconnects occur the same way, through software commands, regardless of how the command was scheduled (either on-demand, or through a pre-scheduled operation). However, there are two different types of reconnect operations: automatic, and reconnect with user intervention.

In an automatic reconnect operation, the reconnect occurs at the time the command is received with no further delay, assuming there is no voltage detected on the load side.

The meter only accepts a disconnect/reconnect event and a scheduling event from authorized personnel. The meter authenticates received events and verifies that they are triggered by authorized personnel. Duplicate service disconnect/reconnect events are detected and ignored. When the meter receives a disconnect procedure and it is already disconnected, the meter just tries to disconnect again. It does not check the state of load side voltage first. When the meter receives a connect procedure, it logs load voltage present. For example, if a meter is already connected and the meter receives a reconnect event, then the meter accepts the event, but takes no action. The meter logs the date, time, and status of attempts to operate the remote service. Log entries include the requesting user or system identity. The meter monitors the load side voltage to determine if voltage is present when the switch is in the off state. If voltage is detected, the switch will not close and a log event is generated. The event also can be configured to trigger an alarm.

The meter continuously performs self tests to its service switch and supports remotely- (via wireless communications) initiated meter testing for service switch status.

Load Side Voltage Detection

Load side voltage is determined by continuously monitoring the presence of AC voltage on the load side voltage terminals. A request can be sent to the meter to determine the presence of load side voltage.

The meter also indicates the presence of load side voltage under the following conditions:

- A command has been sent to request the switch to connect and load side voltage is detected.
- A command has been sent to request the switch to disconnect and after disconnect load side voltage is detected.
- Once a minute, the meter checks the state of load side voltage, and compares that to the requested state of the switch. If the switch should be connected, and load side voltage is absent, the meter retries the connection. If the switch should be disconnected and load side voltage is present, the meter tries to disconnect the service. For connects and disconnects caused by a user request, the number of configured retries controls how many attempts are made before logging failure and sending an exception, if configured. For service limiting, there is no limit to the retries. The meter continues retrying until successful.

Switch Behavior

Connect

During a normal **connect** operation, load side voltage is not detected and the service switch is closed. This results in the presence of load side voltage, so the meter logs a *Connect Activated* event.

Other possible scenarios during a **connect** operation are:

- Load side voltage is detected, so the service switch is not closed. The meter logs a *Load Voltage Present* event. The meter will not attempt to close the switch when load side voltage is present.
- Load side voltage is not detected and the service switch is closed; however, after the switch is closed, load side voltage is still not detected. The meter logs a *Connect Failure* event.

Initial Meter State (load side voltage)	Resulting Switch Action	Resulting Meter State (load side voltage)	Event Logged	Resulting Display Indicator	Notes
Present	None	Present	Load Voltage Present	ds LOAd	Will not attempt to close switch when load side voltage is present
Not Present	Switch Closed	Present	Connect Relay Activated		Normal operation
Not Present	Switch Closed	Not Present	Connect Relay Failure	dsErr	Switch error detected

Disconnect

During a normal **disconnect** operation, load side voltage is detected and the service switch is opened. This results in the absence of load side voltage, so the meter logs a *Disconnect Activated* event.

Other possible scenarios during a **disconnect** operation are:

- Load side voltage is detected and the service switch is opened; however, after the switch is opened, load side voltage is still detected. The meter logs a *Load Voltage Present* event. This scenario occurs only when the switch fails to open, is bypassed, or voltage is being generated on the load side.
- Load side voltage is not detected and the service switch is opened. Load side voltage is still not detected, so the meter logs a *Disconnect Activated* event. This scenario occurs when attempting to disconnect a meter that is already disconnected.

Initial Meter State (load side voltage)	Resulting Switch Action	Resulting Meter State (load side voltage)	Event Logged	Resulting Display Indicator	Notes
Present	Switch Opened	Not Present	Disconnect Relay Activated	dsOFF	Normal Operation
Present	Switch Opened	Present	Load Voltage Present	dsLOAd	Occurs only when switch fails to open, bypassed, or generating. Will attempt to correct on retry.
Not Present	Switch Opened	Not Present	Disconnect Activated	dsOFF	Occurs if attempting to disconnect a meter that was already disconnected.

Metering Applications

Meter Programming

The OpenWay Riva CENTRON meter allows for two programming/reconfiguring methods, locally using FDM Tools via wi-fi or remotely using the network.

OpenWay configurations are meter programs that control how the meter records billing data, displays information, and functions. The system of record for all configurations is the OpenWay Operations Center (OWOC). Meter configurations can only be created and edited through the OWOC. Configurations can be downloaded to the endpoints via the OWOC or locally via FDM Tools (for contingency only).

OWOC/FDM Tools Programming

When configuring endpoints over the network, the OWOC compares the configuration of the endpoint (based on its configuration group) with the new configuration. Only the items identified as delta values are reconfigured in the meter. Based on the differences (for example, Energy, Load Profile, Display) the data in the meter may or may not be affected. The table below lists changes and their effects on data storage in the meter.

Changes Made to	Energy Reset to 0	Load Profile Cleared	Events List Cleared	TOU Cleared	Self Read Reset
Quantities (Energy) (First energy will be non – zero for new energies)	NO	NO	NO	NO	YES
Load Profile (Interval lengths, quantities)	NO	YES	NO	NO	NO
TOU/Time on existing TOU meter	NO	NO	NO	NO	YES
Adding TOU to non-TOU meter	NO	NO	NO	NO	YES
Voltage Profiling (Only clears VP data)	NO	NO	NO	NO	NO
Display	NO	NO	NO	NO	NO
Events	NO	NO	NO	NO	NO

Registers

The following are register quantities in the OpenWay Riva CENTRON meter:

- Energy
- Self-Read
- End-of-Billing
- Instantaneous
- Information

Energy Registers

The OpenWay Riva CENTRON meter can measure numerous energy quantities (as shown in the following table) from which the user can configure any four to be registered based on the meter's device class.



Note If an energy register that is being used in the Load Profile is edited, the current interval for that quantity will be affected.

Measured Energy Quantity Type	Phases	Directions
watt-hours	aggregate	delivered (import) received (export) net (delivered - received) uni-directional (delivered + received)
VA-hours (vectorial or arithmetic)	aggregate	delivered (import) received (export) net
VAR-hours	aggregate	delivered (import) received (export) Q1-Q4

Energy Data Display Items

Energy Data Display Item
Wh (delivered, received, net, uni-directional)
VAh (delivered, received, net)
VARh (delivered, received, net)(Q1 - Q4)

Self-Read Registers

When enabled, the meter will store one self-read per day. The self-read is configurable to any time of the day with the resolution of one minute. The meter will store up to twelve self-reads on a first in-first out basis.

End-of-Billing Registers

By default, the meter will store end-of-billing data. The meter will store up to twelve end-of-billing reads on a first in-first out basis.

Instantaneous Registers

The OpenWay Riva CENTRON meter also stores instantaneous registers.

Instantaneous Data Display Items

Instantaneous Data Display Item
Instantaneous RMS Volts
Instantaneous RMS Current

Information Registers

The OpenWay Riva CENTRON meter also stores a significant amount of informational data. These non-registered values are listed in Informational Data.

Enhanced Security

Itron Security Manager (ISM) enhanced security adds an additional layer of defense onto the basic security that meets National Institute of Standards and Technology (NIST) cryptography requirements.

At the application level, Itron Enhanced Security provides a security architecture that emphasizes integrity of control, availability, and confidentiality. Commands and payloads are encrypted and digitally signed before transfer over the network. In this manner, the messages between the applications and meters are protected, regardless of the underlying network infrastructure. Itron Enhanced Security also provides auditing of both the security activities and the events being returned by the meter, managing the encryption keys, and managing the larger set of security components deployed with the AMI system. The Itron Enhanced Security operates from the headend system to the register in the endpoint on authenticated control commands.

Every device in the system includes a set of asymmetric keys for authentication and non-repudiation functions as well as a set of symmetric keys for confidential message transmission. Data transmitted over the network is protected using AES-128 encryption. AMI system commands are digitally signed using ECC asymmetric cryptography and also encrypted using AES-128. For each AMI message, there is also a time stamp used to prevent message replay attacks. The OpenWay Riva CENTRON Meter does not process messages that are outside the acceptable window.

ISM is true application-layer security that ensures secure network communications from the endpoint to the head end. ISM enables data privacy through encryption and secures communications through authentication. ISM is required in systems capable of service disconnects or metrology device reprogramming.

Metering Applications

Authentication ensures only authorized users can access the network. Authentication techniques used in the OpenWay solution:

- User ID and password
- AES-CCM mode Advanced Encryption Standard that uses counter with cypher-block-chaining message-authentication code
- Digital Certificates

Key Elements

Itron Security Manager (ISM) for the OpenWay Solution provides confidentiality, integrity and authentication over multiple layers of security. Enhanced security protects critical information from head end applications to readers with an additional security layer. This extra security layer between our readers and endpoints provides the confidentiality that end-consumers require and the authentication to manage networks securely. The extra security layer features two-way data authentication between collection systems and endpoints as well as endpoint data encryption.

- Authentication verifies that a message from a user or device is valid, and in its original form. Authentication is accomplished using passwords or digital signatures supplied by the device or computer program. An OpenWay system endpoint knows that only its trusted security server could send the message and that it can be trusted. Authentication verifies encrypted or plain text messages.
- Encryption transforms information (typically plain text), using an algorithm to make it unreadable to anyone except those possessing special knowledge, usually referred to as a key. Encryption typically is one of two forms: symmetric and asymmetric.
- Symmetric encryption uses the same key to encrypt and decrypt the same message.
- Asymmetric encryption uses two keys; a public key and a protected private key. Public keys allow anyone to send a message coded with the public key. Only the intended recipient can decrypt the message with the private key. The ISM uses symmetric encryption between endpoints and data collection applications.
- Key Management supports encryption and authentication across the solution. A centralized key server securely manages the encryption keys for all endpoints and readers across the system. The OpenWay solution deploys the software-based ISM to administer both the encryption and authentication processes. The OpenWay solution, adds this key manager for another layer of security on top of the standard PKI server application used to secure communications between the readers and the collection system.

Signed Authorization

Local communication to OpenWay Riva CENTRON meters is achieved using WiFi wireless technology. Using the Field Deployment Manager (FDM) tools application, a user can log into a meter to perform various tasks. WiFi communication security is based on two principles.

- The meter does not send a beacon signal announcing its presence. The meter waits for the endpoint tool to request a connection to the meter.
- WPA2-AES-128 bit encryption is used for communication.

A secure connection between Itron devices and FDM requires a WiFi connection, Transport Layer Session (TLS) and Signed Authorization validation.

The laptop attempts to connect with the meter using a derived SSID. Meters with WiFi are configured to look for WiFi connection requests with a particular SSID. Authentication and encryption is enforced using device WiFi certificates issued to the meters and WiFi certificates issued to the laptop.

After a TLS is established between the FDM and the meter, the meter waits for a Signed Authorization token from the FDM. A signed Authorization token is issued to the user of the laptop by the OWOC and signed by the Itron Security manager (ISM). This token is time-based and expires at a predetermined time.

If there is no Signed Authorization token or the token is invalid, the TLS is ended and an increasing delay is introduced for subsequent attempts at connection. If the Signed Authorization passes verification, the laptop can communicate securely with the exposed services on the meter.

The Signed Authorization is controlled by the customer as it is signed by one of the command signing keys in the ISM owned by the customer and gives the customer control over access to the meter.

Performing operations on the meter is also secured using user-based permissions within the FDM endpoint tools application. A field technician can only perform actions based on the level of permissions assigned to that technician.

Tamper Detection

The OpenWay Riva CENTRON meter reports all attempts at tampering to the network. The following tamper events are defined:

- Magnetic Tamper Detect
- Magnetic Tamper Cleared
- Outage
- Reverse Energy

Tamper events are sent to the system with a daily read or can be configured to send real time alarms.

Display Items

The OpenWay Riva CENTRON meter normal display mode has a list of items (quantities) it can display. The aggregate of items associated with a display mode is called a display list. The OpenWay Riva CENTRON meter can display a maximum of 80 items; all items are user-selectable. The display items, sequence of display, display ON and OFF times, along with any desired annunciators or ID code number are selected during configuration setup in the OWOC Administrative Tool. On and OFF times are configurable from 1 - 15 seconds inclusive..

The following types of displayable items are available:

- Energy Registers
- Power Factor
 - Minimum
 - Present
 - Previous
 - Projected
- Instantaneous Voltage
- Instantaneous Current
- Informational Display Items

Numerical values may be displayed in various formats depending on configuration. For example, kilo units, mega units, fixed decimal point, floating decimal point, and leading zeros can all be configured.

The following tables show items programmable for display in the modes indicated.

All of the display items in the next two tables may be selected by TOU Rate. They also may be selected from the Self Read buffer.

Informational Data Display Items

Informational Data Display Item
Segment Test
Meter Local Date
Meter Local Time
Minutes on Battery
Register Firmware Version
Register Firmware Revision
Network Sync Status
Network Link Status
Registration Status
Disconnect Status

Time Synchronization

Time synchronization is an automatic feature that periodically checks synchronization of the meter time every 60 minutes. If the time in the meter gets more than the configurable time threshold off from the main system time, the meter adjusts time. System time is provided to the meter by the network and is based on network time which is synchronized to an NTP server. The time is propagated through the network and checked at each endpoint for the above described parameters.

In the case that a meter's time is off from the system time by more than the maximum time threshold, the meter will no longer synchronize its time with the network automatically. In this case, the user can use the Force Time Sync functionality available in FDM or the OWOC which generates an event that is recorded for later retrieval.

If the time is off by more than 10 minutes, any call by the system is treated as a replay attack. In the case of a forced time sync, the replay attack is ignored for this one message as follows:

1. The OWOC sends a request to the meter to do a time sync operation.
2. If the requested message is built on the enhanced security mechanism, then the meter processes it without logging a replay attack.
3. After the meter has processed the message, it logs a history event to indicate whether the time sync operation is a success or a failure.

Time of Use (TOU)

The Time of Use (TOU) functionality is designed for use in billing applications where multiple rates (bins) are required. The TOU option provides nine rates plus the total rate.

Time of Use Schedules

Calendar Schedule

The OpenWay Riva CENTRON meter supports a 25 year calendar. The calendar schedule contains all daily information needed for the meter to measure and register data in real time. The schedule contains daily patterns with configurable day types and rates.

Rates

Eight independent rates are available for TOU registration. These are designated A through H. Only one of these rates can be active at a time. The Total register, designated Rate T, is always active, regardless of the active rate period.

The OpenWay Riva CENTRON Register TOU rates are applied to all energy registers that have been selected for measurement. Therefore, all energy registers are segmented as per the TOU schedule and available in each rate period, in addition to the Total rate.

Daily Patterns

Each pattern defines the times during the day that rate periods 1 through 8 begin and end. Up to 48 rate period changes may be specified for each daily pattern.

Day Types

There are eight day types: Day 1 Day 7, and Holiday. Each day of the week is assigned to one of the eight day types. Each day type is assigned one of the daily patterns when each season is defined. Any of the daily patterns can be used in any combination with the day types.

Holidays

Holidays can be set up either as Fixed or Recurring. Fixed holidays are defined as a single date. Recurring holidays repeat every year. The Recurring Date Type options allow you to determine whether the holiday occurs on the same date every year or moves to another day if the date falls on a Saturday or Sunday.

A maximum of 50 holidays can be set up per season.

Seasonal Schedules

A season is a period during the year when a particular rate structure is in effect. Multiple seasons (up to four fixed or recurring) can be set up per year. Only one seasonal TOU calendar can operate within the meter at a time.

TOU Registers

Current Season Registers

All energy TOU registers stored on the meter are current season registers.

TOU Operation

This section describes TOU operation specific to the meter display. Several TOU indicators are available on the liquid crystal display (LCD).

Rate Annunciators and Active Rate Indicators

Rate annunciators are available with each energy register. An A through H will be displayed on the far bottom right side of the LCD to indicate the rate period for each quantity being displayed.

If the rate annunciator is flashing while an energy value is displayed, the annunciator indicates that it is the current rate in effect. This gives a quick indication that the register is configured with the correct TOU schedule and that it is currently set to the correct time.

Season Change

Because the meter can be programmed for up to 25 years, there can be numerous seasons and switchpoints, all of which can be changed at any time through the network. Alternately the TOU can be changed at any time as part of a configuration download.

Load Profile

The OpenWay Riva CENTRON meter supports up to eight channels of load profile. The profile interval length is the same for all channels. Each interval of load profile data is identified by date and time. Each interval contains status bits indicating the occurrence of outages, Daylight Saving Time, and other significant events.

The Load Profile functionality is designed for use in billing and load research applications where multi-channel high resolution data is needed.

Load Profile Specifications

Interval Lengths

The load profile records data on a block interval basis. The interval length is programmable for 5, 10, 15, 30, or 60 minutes. The interval length is the same for all channels.

Power Outage

The OpenWay Register flags an interval when a power outage exceeds a specified number of seconds. The range for power outage length is programmable from 0 to 255 seconds and must not exceed the programmed interval length.

- During power outages the OpenWay Riva CENTRON meter maintains all meter data as well as timekeeping functions (powered by the internal battery).
- During an outage, billing data is stored in non-volatile memory.
- When power is restored, data is returned to active memory and normal metering resumes.
- The meter records the date and time of the power outage and the power restoration.

Load Profile

During power-up processing, the Load Profile component checks if the duration of the outage exceeds the configured minimum duration time. If it does, then at least one interval is tagged with an outage status. The interval that was active when outage occurred is tagged as a short interval due to the outage. If the outage ended in the middle of another interval, then that interval is also tagged as a short interval due to the outage.

Channel Configuration

The OpenWay Riva CENTRON register can be programmed to have up to eight channels of interval load profile data. Each channel corresponds to an energy register selected during creation of the program file. In order to profile a specific energy, the energy must first be selected as a quantity to be measured.

Selection of channel configuration and pulse constants is accomplished through the programming software. Each data channel is programmed to record load profile data from a user-selected register.

Load Profile Storage

The load profile has dedicated memory. The table below shows the recording time in days for all possible profile configurations before data rollover begins.

Number of Channels	Interval Length (Minutes)				
	5	10	15	30	60
1	190	380	570	1140	2280
2	119	238	356	713	1425
3	86	173	259	518	1036
4	68	136	204	407	814
5	56	112	168	335	671
6	48	95	143	285	570
7	41	83	124	248	496
8	37	73	110	219	438

The following are the status codes used when viewing the load profile data.

Status	Definition	Cause
A	Time Adjustment	The meter time was adjusted during the specified interval. When A appears, you also see a status of K, L, or S, indicating whether the time adjustment caused an interval to be skipped or to be longer or shorter than normal.
D	In DST	The interval occurred during Daylight Saving Time.
K	Skipped Interval	The interval was skipped and no data was recorded. Intervals can be skipped due to either a power outage or a time adjustment during that interval.
L	Long Interval	A time adjustment occurred during the interval causing it to be longer than the normal interval length.
O	Outage	An outage occurred during the specified interval. The minimum outage length is recorded in seconds and is specified in the Collection Engine in the load profile section.
R	Power Restoration	Power was restored after a power outage during this interval.
S	Short Interval	The interval was shorter than normal either because of an outage or a time adjustment.

In addition to the interval profile data and the interval status data, each message contains a time tag specifying the month, day, hour, and second of the end of the data interval.

Recording Duration

The OpenWay Riva CENTRON meter supports up to 8 channels of load profile data. These channels can be configured to profile any available energy value including kWh, kVAh, and kVARh. The interval length can be configured to 5, 10, 15, 30 or 60 minutes.

Voltage Monitoring

Voltage monitoring, when configured, logs events for voltage sags and swells. The upper and lower RMS limits are configurable in the OWOC Administrative Tool. The thresholds are designated as a percentage of the nominal voltage and range from +20% to -20%. In addition to configurable thresholds there is also a configurable Instantaneous Voltage High/Low Latency time, which can be configured from 0-100 seconds, inclusive.

Voltage profiling, when configured, will monitor and record voltage values. The voltage profiling interval can be configured to be 5, 10, 15, 30, or 60 minutes in length. The configurable values are, minimum voltage, maximum voltage, average voltage and instantaneous voltage.

Nominal Voltage

Nominal voltage is determined by the meter voltage configured at the time of manufacture. All voltage monitoring configurable thresholds are specified in percentages of nominal voltage.

VM Threshold Monitoring

Every one second during the interval, current RMS voltage is compared with minimum and maximum voltages in each phase. If current RMS voltage is less than the minimum voltage, the minimum voltage is set to be current RMS voltage. If current RMS voltage is greater than the maximum voltage, the maximum voltage is set to be current RMS voltage.

At EOI, Voltage Monitoring checks if the minimum voltage value during the interval is below the RMS Low Voltage Threshold or the maximum value during the interval is above the RMS High Voltage Threshold. If either condition exists, a corresponding event is recorded and a bit is set in the interval status. The minimum and maximum values are reset for next interval tracking.

Voltage Profiling

The OpenWay Riva CENTRON meter can be configured to record up to nine channels of voltage profile. Voltage profile is a type of interval data. Each interval contains a per-phase instantaneous reading of a configured quantity at a configured offset from the start of the interval. Configured interval lengths are synchronized to the top of the hour and can be set to 5, 10, 15, 30, or 60 minutes. Interval lengths are the same for each selected channel.

The profile interval length is the same for all channels and is independent of the interval lengths for other types of interval data. Each interval of voltage profile is identified by date and time and contains status bits indicating the occurrence of outages, Daylight Saving Time, and other significant events or errors.

Voltage Profile Specifications

Capacity

The voltage profile has dedicated memory. The table below shows the recording time in days for all possible instrumentation profile configurations before data rollover begins:

Number of Channels	Interval Length (Minutes)				
	5	10	15	30	60
1	189	378	566	1133	2265
2	118	236	354	708	1416
3	86	172	257	515	1030
4	67	135	202	404	809

Remote Disconnect/Reconnect

The remote disconnect/reconnect version of the OpenWay Riva CENTRON meter contains control circuitry with a 200A switch that allows the service to the premises to be switched on or off remotely through the OpenWay system or locally via FDM Tools.

Event (History) Log

The OpenWay Riva CENTRON meter has a log that records historical events that have taken place in the meter. The event log is circular in nature, allowing for the capture of the most recent events in the meter at all times. The meter is capable of retaining 1000 events prior to wrapping.

Each event log record includes an event description, a time and date stamp, and additional information on certain events. All logged events are retained through a power outage.

The OpenWay Riva CENTRON meter can monitor exceptions. Exceptions are sent to the OpenWay Operations Center as soon as possible after their occurrence, but are not stored in the meter as other events are. All events in the OpenWay Riva CENTRON meter can be configured as exception alarms.

Metering Events

Event Name	Event Description
Base Communications Error	Logged when a communication error with the metering base is detected.
Force Save Request Failed	Forced Save Request Failed for three minutes.
Blurt Loss Exceeded Timeout	Metrology communication has halted for 15 minutes.
Billing Data Cleared	Logged when a 'clear billing data' command is received and executed.
Reverse Energy Detected	A certain amount of energy has accumulated in the 'reverse' direction without any accumulation in the 'normal' direction.
Reverse Energy Cleared	After a reverse energy detected event, energy has begun to flow in the 'normal' direction again.

Self Read Events

Event Name	Event Description
Self Read Occurred	A self read of some type has occurred.
Self Reads Cleared	All Self Read history and capture value data has been deleted.
Self Read Data Failure	A failure occurred while trying to capture the data for a LID configured for the self read.
End of Billing Period	This event is logged when meter data is captured in a unique set of buffers at the end of the configurable billing period.

Voltage Events

Event Name	Event Description
Voltage Anomaly	Nominal voltage has dropped below or risen above the set threshold on one, some, or all phases.
Voltage Restored	Nominal voltage has been restored to normal levels on one, some, or all phases.

Current Events

Event Name	Event Description
Current High Anomaly	Current has risen above the set threshold on one, some, or all phases.
Current Low Anomaly	Current has dropped below the set threshold on one, some, or all phases.
Current Restored	Current has been restored to normal levels on one, some, or all phases.

Power Outages

Event Name	Event Description
Power Outage Detected	Occurs on power outage.
Power Restoration Detected	Occurs on power restoration.

Firmware Download Events

Event Name	Event Description
Image Activation Attempted	Logged at 3 different times: <ul style="list-style-type: none"> • When scheduling the image activation finishes or fails • When starting the image activation finishes or fails • When the final image activation process finishes or fails
Image Transfer Initiated	Logged after an initiate request is received and processed.
Image Transfer Canceled	Logged after a cancel request is processed.
Image Validation Attempted	Logged at several points throughout the validation process, after each stage has completed.

Tamper Events

Event Name	Event Description
Magnetic Tamper Detected	A magnetic tamper of a meter in the network has been detected.
Magnetic Tamper Cleared	A magnetic tamper of a meter in the network has been cleared.

Connect/Disconnect Events

Event Name	Event Description
Remote Disconnect	Logged if <ul style="list-style-type: none"> • Remote Disconnect Relay is initiated • Disconnect relay is successfully activated and no load voltage is seen • Remote Disconnect fails
Remote Connect	Logged if the connect relay is successfully activated and load voltage is present.

System Events

Event Name	Event Description
Time Change Forward	A system time change forward occurs either manually or via an automatic time synch mechanism.
Time Change Backward	A system time change backward occurs either manually or via an automatic time synch mechanism.
Device Reconfigured	The device has attempted to perform a reconfiguration.
Event Log Cleared	The device has received a command that caused it to clear its logged events.
Low Battery Detected	Battery level is below the low voltage threshold.
Dead Battery Detected	An inspection of the battery levels indicates the level is below the dead battery threshold.
DST Periods Exhausted	The current time in the meter has advanced past the end time of the last daylight saving time period. From this point on DST cannot be observed and the meters' local time is not guaranteed to be accurate.
System Reboot	A system reboot has been logged at the reboot time.
System Restart	A system restart has been logged at power-up time.
Time Invalid	Time was estimated at power-up. Time-based metering is stopped until the time is set externally.
Time Outside Automatic Sync Threshold	Time synchronization failed because the clock was off by more than the configured maximum adjustment. An exception on this event alerts the user to perform a force time sync to fix the condition.
Time Adjustment Failed	Adjustment of the clock has failed.
Configuration Downloaded	A new un-activated configuration file is received by the meter.

Security Events

Event Name	Event Description
Communication Device Failed to Authenticate	Occurs when a communicating device tries to authenticate, but fails to do so properly.
Replay Attack	Occurs when a message is received that has a timestamp that is older than configured allowed window. Time sync is exempt from this restriction.
Local Access Initiated	Established when a local connection is established with the meter.
Local Access Terminated	Occurs when a local meter is released.
Signed Authorization Failed	Occurs when an attempt to connect to a meter using signed authorization fails.

TOU Events

Event Name	Event Description
Season Change	A season change has occurred.

Testing, Troubleshooting, and Maintenance

Testing

Recommended Energy Testing Procedures

Iron recommends using modern test boards with the latest software to test its electrical meters. Otherwise, erroneous readings could occur on light-load tests when the test sequence calls for a light-load test following a full-load or power-factor test. When proper testing equipment is not used, power-factor readings may also be in error when following a full-load test. The errors are always positive and may be a few percent for power-factor and even greater for light-load. The problem is aggravated on lower voltages and when using large test constants, K_t , similar to the typical K_h values of comparable induction meters.

Visual Indicators

The OpenWay Riva CENTRON meter is equipped with an Infrared (IR) Test Light Emitting Diode (LED) for testing meter accuracy. The LED is located on the front of the meter.

Annunciators

Load Indication/Direction Annunciator

The OpenWay Riva CENTRON meter is equipped with a Liquid Crystal Display (LCD) load emulation indicator. The Load Emulator follows the Infrared Test LED. For each pulse of the Test LED, the Load Emulator increments one segment. The operation of the Load Emulator is based on the bi-directional Wh energy.

The Load Emulator scrolls to the right when energy is being delivered and scrolls to the left when energy is being received.

Troubleshooting

Error Modes

The OpenWay Riva CENTRON meter provides two error modes.

- Diagnostic Error mode
- Error mode

Diagnostic Error Mode

Diagnostic errors indicate improper installation of the meter or other meter errors. Each error produces an event to indicate the occurrence of the problem. The displaying of these messages on the meter is configurable. If display messages are enabled the diagnostic error will display between each of the normally configured display items.

Diagnostic Error	Display(optional)
Clock Error	dE 1----
Low Battery Error	dE -2---

Error Mode

These errors indicate there has been an error condition on the meter that prevents metering from operating properly. When these error conditions occur the error code is locked on the meter display and energy accumulation stops.

Error Display	Error Description
Er1001	Metrology stopped talking for 15 minutes
Er1003	No time or time goes backward
Er1004	Fail to do a force save

Error Code Displays

The user may configure the behavior that the meter should exhibit for active error conditions. If active errors are selected to be displayed the error code is displayed between each configured display item.

Network Troubleshooting

Link status information is available on the LCD in the format 'MHxxSx' where:

Field	Description
M	Media information between this node and its best parent (one character)
Hxx	number of hops to the root (three characters)
Sx	estimated quality between this node and its best parent (two characters)

Communications Media

This parameter shows the modulation that is used to communicate with the meters' parent.

Media	Description
'r'	rf media
'p'	plc media
'O'	unknown media

Number of Hops

This parameter shows the number of hops between this meter and the root.

Displayed Indicator	Description
Hxx	'xx' represents the number of hops (0-32) between this meter and the root

Link Quality

This parameter represents the estimated link quality (0-5) between this meter and its best parent.

Displayed Indicator	Description
Sx	'x' represents the link quality (0-5) between this meter and the root

Maintenance

Preventive Maintenance

No scheduled or preventive maintenance is necessary for the meter.

Line potential may exist on the battery terminals. Follow these precautions:



- Never short-circuit batteries (such as by measuring current capability with an ammeter).
- Do not recharge batteries.
- Do not store or transport batteries in metal or other electrically conductive containers.
- Keep batteries separated. If stored in a container where they can contact each other, face them in the same direction to prevent short circuits.
- Do not operate batteries at temperatures above 85°C (185°F).
- Dispose of batteries where they will not be punctured, crushed, or incinerated.
- Discard the battery using proper hazardous waste procedures.

Corrective Maintenance

Because of the high level of integrated packaging and surface-mount components, on-board component repairs are not recommended.