

1 TYPICAL JUNCTION BOX PLAN VIEW
SCALE: N.T.S.

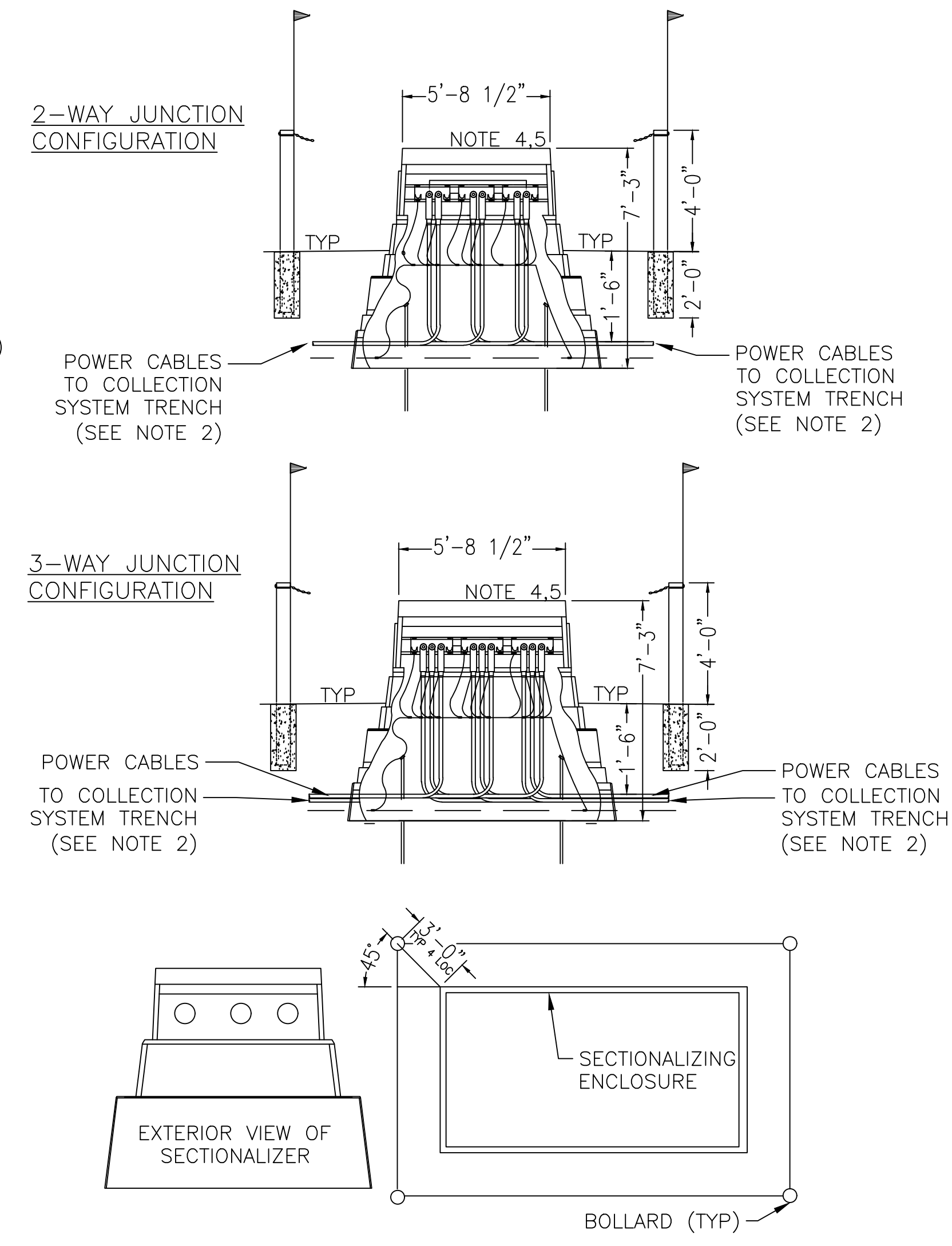

2 BOLLARD DETAIL
SCALE: N.T.S.

BILL OF MATERIALS		
MARK	QTY	DESCRIPTION
C101	A/R	HDPE INNER DUCT, 1.25" SDR 13.5
G100	1	GROUNDING CONNECTOR, COMPRESSION, #2 Cu TO GROUND ROD
G101	2	GROUNDING CONNECTOR, #2 AWG SOLID TO TRENCH GROUND
G200	1	GROUND ROD, 5/8" x 10' COPPER
K100	A/R	35kV CABLE PER CABLE SCHEDULE
K200	A/R	12F - FIBER OPTIC CABLE
K310	A/R	#2AWG SOLID Cu, BARE
M200	1	MARKER BALL
M201	A/R	WARNING TAPE
M202	3	PHASE MARKINGS
R300	3	SPLICE KIT, 35kV INLINE

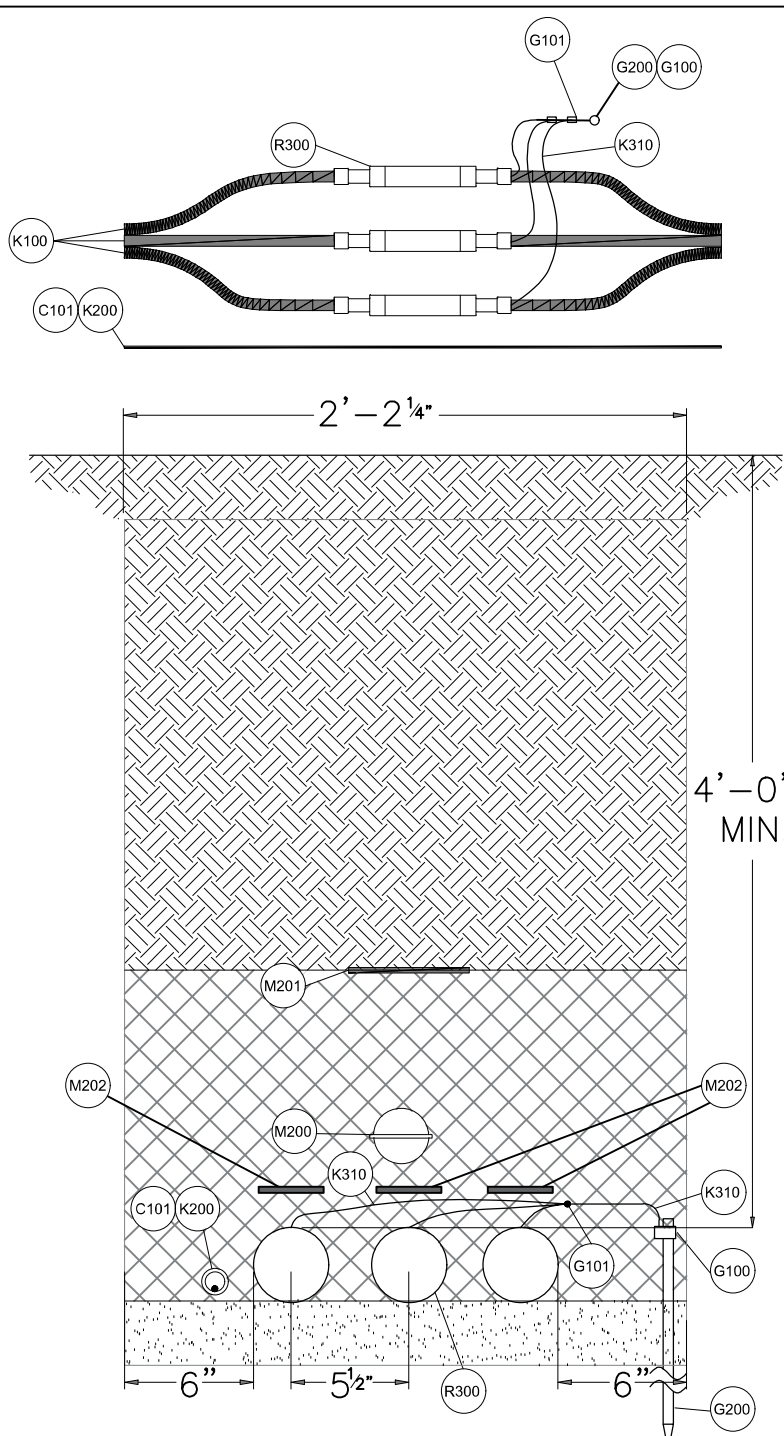

3 MV CABLE SPLICE DETAIL
SCALE: N.T.S.

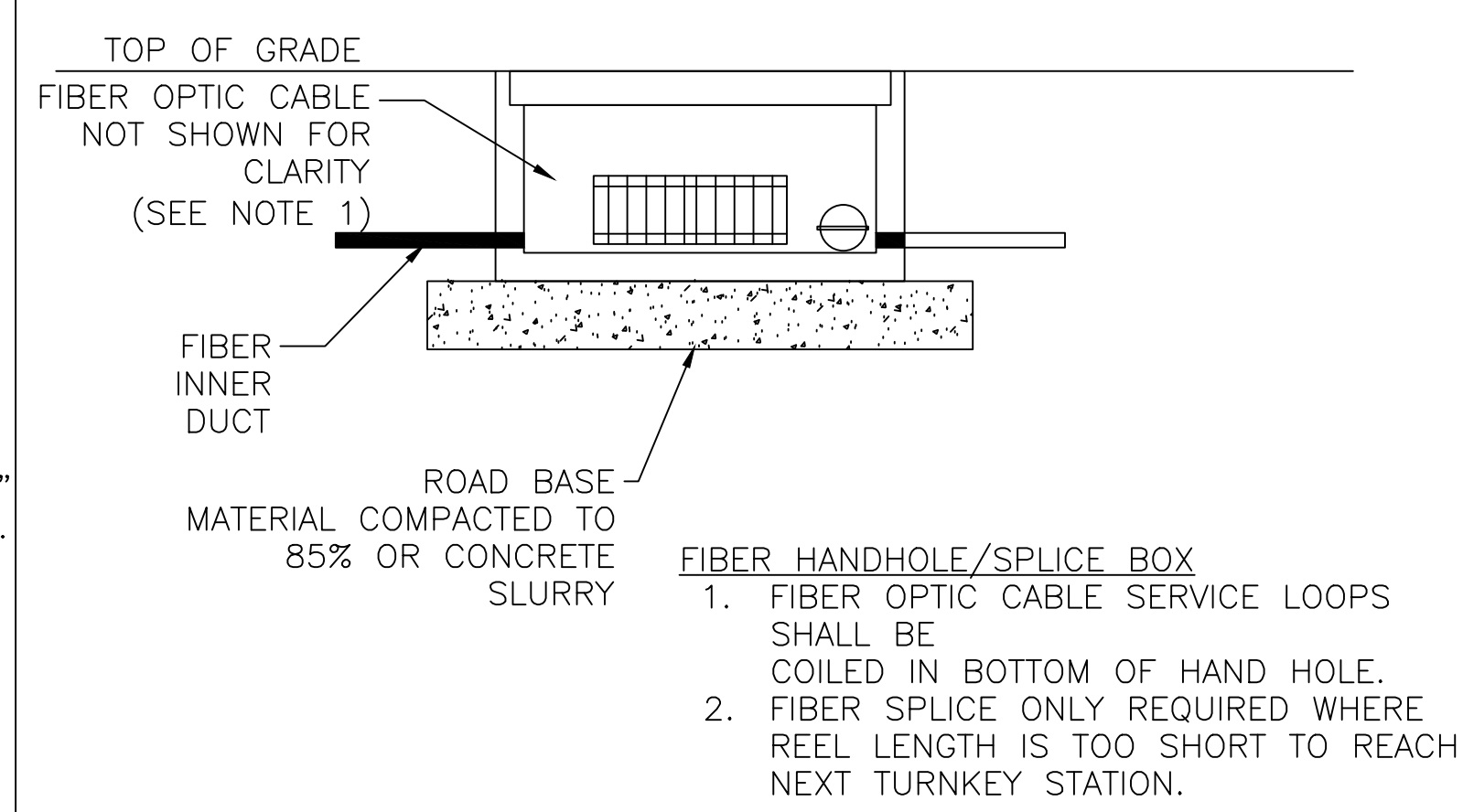

4 FIBER HANDHOLE/SPLICE BOX
SCALE: N.T.S.

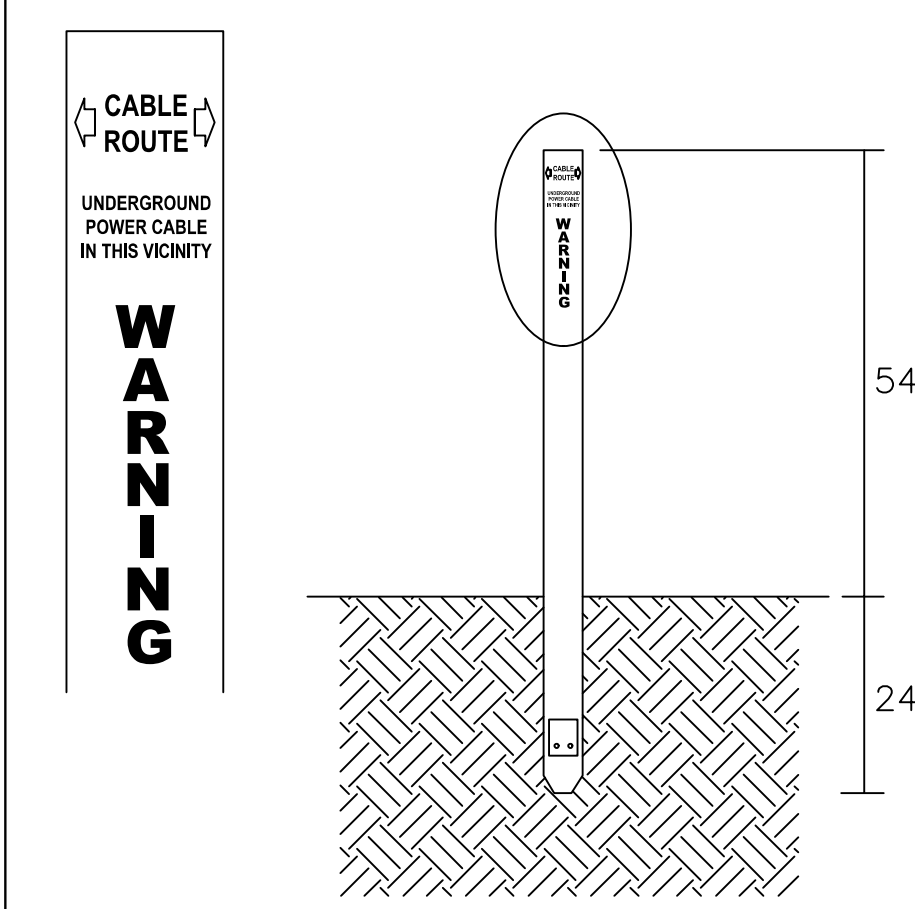

5 CABLE MARKER DETAIL
SCALE: N.T.S.

- GENERAL NOTES:**
- INSTALL IR VIEW PORT PER INSTALLATION INSTRUCTIONS FOR FLK-CLKT, IF POSSIBLE DISPLAY TO FACE ROADWAY
 - INSTALL ONE FULL COIL OF SLACK MV CABLE FOR EACH CIRCUIT, EACH PHASE, 500 KCMIL CABLE SHALL BE COILED INSIDE JUNCTION BOX, 750 KCMIL AND LARGER CABLE SHALL BE COILED OUTSIDE OF JUNCTION BOX, PROVIDE 3M 1422-XR/ID BALL MARKER. INSTALL NO DEEPER THAN 5'-0" AT EACH LOOP. AT THESE LOCATIONS PROVIDE A CONDUIT PAVEWAY/RACK TO HELP PULL IN SLACK CABLE.
 - ATTACH LABELS TO EACH CONDUCTOR IDENTIFYING PHASING AND CIRCUIT # OF THE CABLES. PROVIDE LABELS AT ENTRY AND EXIT.
 - CABLE TERMINATIONS NEAREST TO SUBSTATION SHALL HAVE SINGLE WRAP PHASING TAPE, SIDE AWAY FROM SUBSTATION SHALL HAVE DOUBLE WRAP PHASING TAPE.
 - THE FOLLOWING TAPE SHALL BE USED FOR PHASE INDICATION: RED TAPE FOR PHASE A, WHITE TAPE FOR PHASE B, AND BLUE FOR PHASE C.
 - FINISHED GRADE SHALL BE 2" ABOVE WHERE JUNCTION BOX SECTIONALIZER ATTACH.

REVISIONS:

NO.	DATE	DESCRIPTION
0	01/14/2022	DESIGN DRAWINGS
1	06/27/2022	ISSUED FOR PERMIT

PROJECT TITLE:
BROOKSIDE SOLAR ENERGY FACILITY

PROJECT LOCATION:
TOWNS OF BURKE AND CHATEAUGAY, NY

SHEET TITLE & DESCRIPTION:
SYSTEM SECTIONALIZING AND SPLICING DETAILS

PROJ NUM:	422299
DES:	A. SILVA
DWN:	A. SILVA
CHK:	A. GROSHEV
APV:	
DATE:	01/14/2022
SCALE AT 22" x 34":	

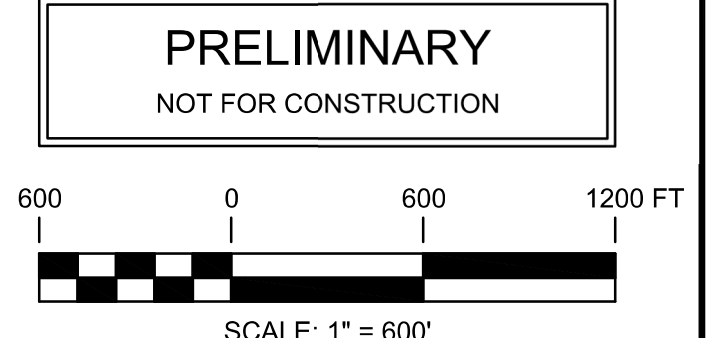

UNDER NEW YORK STATE EDUCATION LAW ARTICLE 145 (ENGINEERING), SECTION 7209 (2), IT IS A VIOLATION OF THE LAW FOR ANY PERSON, UNLESS ACTING UNDER THE DIRECTION OF A LICENSED PROFESSIONAL ENGINEER, TO ALTER THIS DOCUMENT.



2180 South 1300 East, Suite 600
Salt Lake City, UT 84106-2749
(801) 679-3500



249 Western Avenue
Augusta, ME 04330

PE STAMP:



KEY PLAN:

REVISIONS:

NO.	DATE	DESCRIPTION
0	01/19/2022	DESIGN DRAWINGS
1	06/27/2022	ISSUED FOR PERMIT
2	07/20/2022	ISSUED FOR PERMIT
-	-	-
-	-	-
-	-	-
-	-	-

PROJECT TITLE:

BROOKSIDE SOLAR PROJECT

PROJECT LOCATION:

TOWNS OF BURKE AND CHATEAUGAY, NY

SHEET TITLE & DESCRIPTION:

OVERALL LANDSCAPE PLAN

PROJ NUM: 422299

DES: M.ROSS

DWN: T.FIEBRANZ

CHK: M.ROSS

APV: -

DATE: 04/02/2021

SCALE AT 24" x 36":

AS NOTED

SHEET NO:
PV-C.13.00

REV:
1

AES: T:\Projects\2021\422299\04\02\2021\1300\1300-01.dwg (PLOT) 10/2/2021 10:00:00 AM

AES TRIMBLE 22324-VT1011
 C:\WORK\2022\22324-PV\22324-PV-13.02.DWG
 DATE PLOT: 04/02/2021 14:16:54
 C:\WORK\2022\22324-PV\22324-PV-13.02.DWG
 USER: TRM
 C:\WORK\2022\22324-PV\22324-PV-13.02.DWG
 PLOT DATE: 04/02/2021 14:16:54
 PLOT USER: TRM

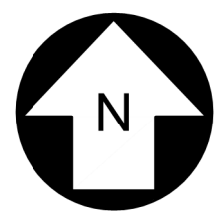

POINT #	MITIGATION SECTION	LATITUDE	LONGITUDE
3	VM-2	N 44.933707	W 74.134812
4	VM-2	N 44.933699	W 74.132155
5	VM-2	N 44.933703	W 74.132109

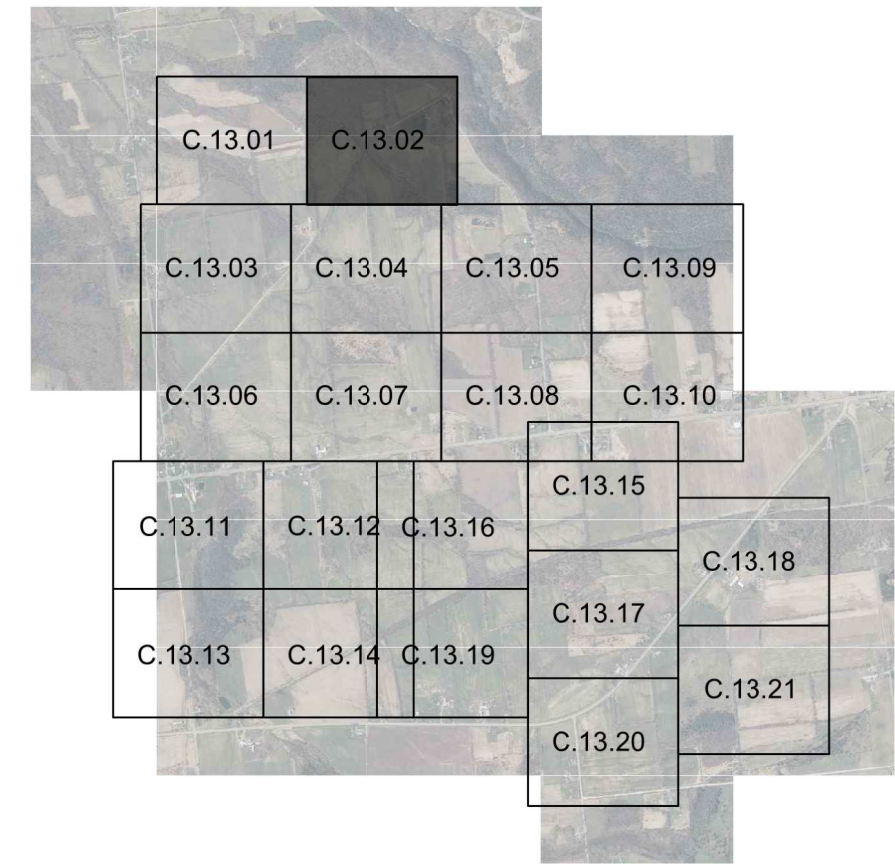

KEY MAP
SCALE: 1" = 3000'

LEGEND

EXISTING	PROPOSED
— — — — —	— — — — —
— — — — —	— — — — —
— — — — —	— — — — —
— — — — —	— — — — —
— — — — —	— — — — —
— — — — —	— — — — —
— — — — —	— — — — —
— — — — —	— — — — —
— — — — —	— — — — —
— — — — —	— — — — —
— — — — —	— — — — —
— — — — —	— — — — —
— — — — —	— — — — —
— — — — —	— — — — —
— — — — —	— — — — —
— — — — —	— — — — —
— — — — —	— — — — —
— — — — —	— — — — —
— — — — —	— — — — —
— — — — —	— — — — —
— — — — —	— — — — —
— — — — —	— — — — —
— — — — —	— — — — —
— — — — —	— — — — —
— — — — —	— — — — —
— — — — —	— — — — —
— — — — —	— — — — —
— — — — —	— — — — —
— — — — —	— — — — —
— — — — —	— — — — —
— — — — —	— — — — —
— — — — —	— — — — —
— — — — —	— — — — —
— — — — —	— — — — —
— — — — —	— — — — —
— — — — —	— — — — —

LANDSCAPE LEGEND

- REPRESENTATIVE PLANTING TEMPLATE 1 (TYPICAL)
- REPRESENTATIVE PLANTING TEMPLATE 2 (ALTERNATIVE)

PRELIMINARY
NOT FOR CONSTRUCTION

100 0 100 200 FT

SCALE: 1" = 100'

UNDER NEW YORK STATE EDUCATION LAW ARTICLE 145 (ENGINEERING), SECTION 7209 (2), IT IS A VIOLATION OF THE LAW FOR ANY PERSON, UNLESS ACTING UNDER THE DIRECTION OF A LICENSED PROFESSIONAL ENGINEER, TO ALTER THIS DOCUMENT.

aes
2180 South 1300 East, Suite 600
Salt Lake City, UT 84106-2749
(801) 679-3500

TRC
249 Western Avenue
Augusta, ME 04330

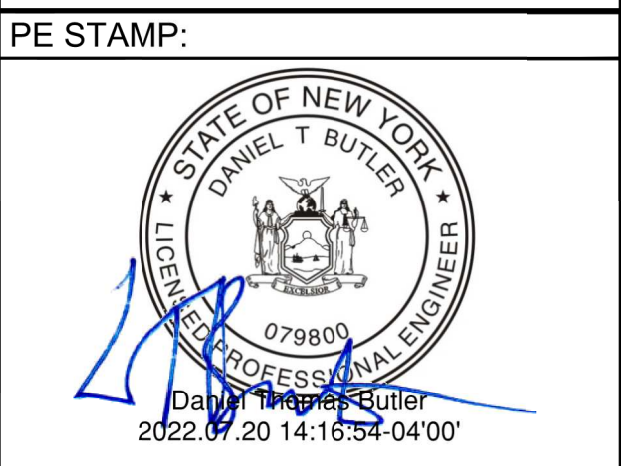

KEY PLAN:

REVISIONS:

NO.	DATE	DESCRIPTION
0	01/19/2022	DESIGN DRAWINGS
1	06/27/2022	ISSUED FOR PERMIT
2	07/20/2022	ISSUED FOR PERMIT
-	-	-
-	-	-
-	-	-
-	-	-

PROJECT TITLE:
BROOKSIDE SOLAR PROJECT

PROJECT LOCATION:
TOWNS OF BURKE AND CHATEAUGAY, NY

SHEET TITLE & DESCRIPTION:
ENLARGED LANDSCAPE PLAN

PROJ NUM:	422299
DES:	M.ROSS
DWN:	T.FIEBRANZ
CHK:	M.ROSS
APV:	-
DATE:	04/02/2021
SCALE AT 24" x 36":	-

AS NOTED

SHEET NO:	PV-C.13.02	REV:	1
-----------	------------	------	---

FOR CONTINUATION, SEE SHEET PV-C.13.01

FOR CONTINUATION, SEE SHEET PV-C.13.04

FOR CONTINUATION, SEE SHEET PV-C.13.05

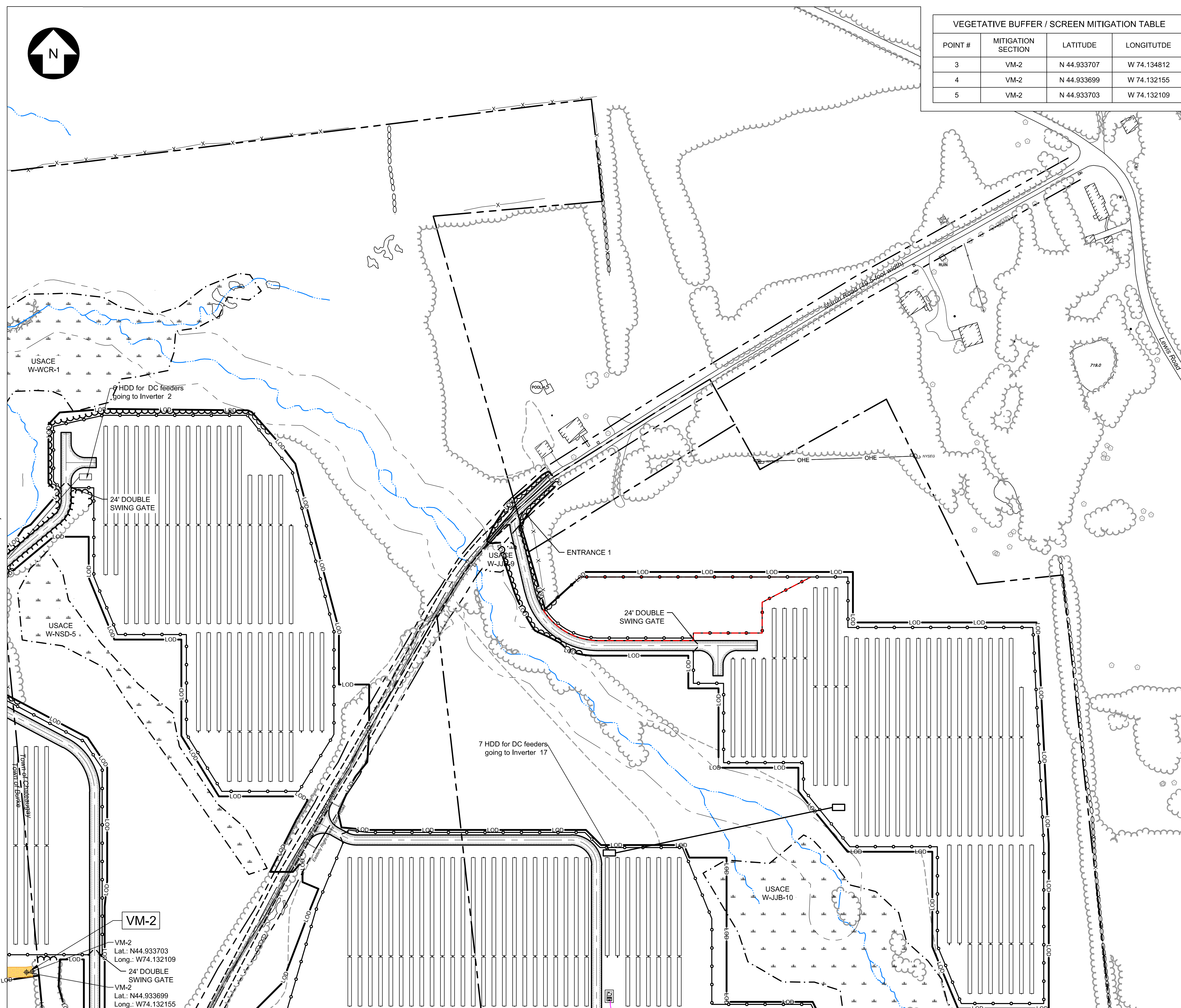

FOR CONTINUATION, SEE SHEET PV-C.13.01



POINT #	MITIGATION SECTION	LATITUDE	LONGITUDE
6	VM-3	N 44.934629	W 74.138649
7	VM-3	N 44.934350	W 74.138732
8	VM-3	N 44.933617	W 74.138736
9	VM-3	N 44.933621	W 74.140004
10	VM-3	N 44.932611	W 74.140010
11	VM-3	N 44.930351	W 74.139707
12	VM-3	N 44.930207	W 74.139695
13	VM-3	N 44.929470	W 74.139582
14	VM-3	N 44.929391	W 74.140606

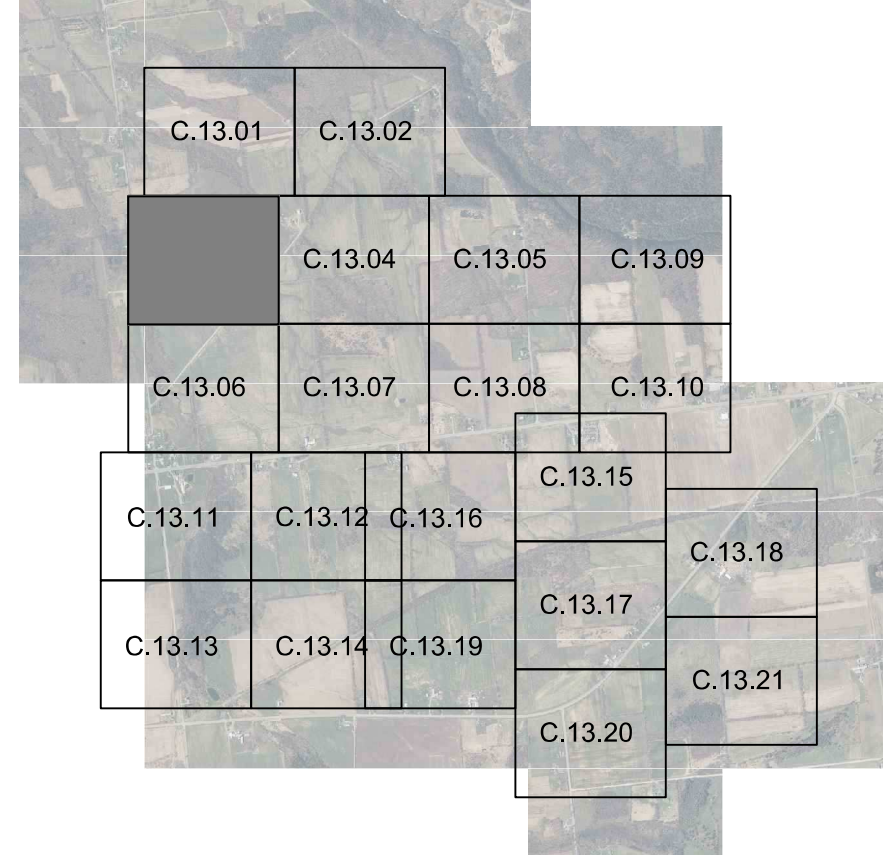

KEY MAP
SCALE: 1" = 3000'

LEGEND

EXISTING	PROPOSED
--- PROPERTY BOUNDARY	--- LOD
--- 94C SETBACK	--- SF
--- TOWN SETBACK	--- SF
--- LIMIT OF DISTURBANCE	--- SF
--- SOIL BOUNDARY	--- SF
--- SILT FENCE	--- SF
--- OHE	--- SF
--- OVERHEAD ELECTRIC	--- SF
--- CHAIN LINK FENCE	--- SF
--- BARBED WIRE FENCE	--- SF
--- GRAVEL ROAD	--- SF
--- BASELINE	--- SF
--- PV ARRAY	--- SF
EQUIPMENT PADS & BOLLARDS	
--- 598	--- 598
--- 600	--- 600
--- MINOR CONTOUR	--- 598
--- MAJOR CONTOUR	--- 600
--- WETLAND	--- 598
--- STREAM	--- 600
--- WATER SURFACE	--- 600
--- TREELINE	--- 600
--- BRUSH	--- 600
--- BUILDING	--- 600
--- STONE WALL	--- 600
--- UTILITY POLE	--- 600
--- VALVE	--- 600
--- CULVERT	--- 600
--- WETLAND ADJACENT AREA / STREAM BUFFER	--- 600
--- LAYDOWN YARD	--- 600
--- TOWN BOUNDARY	--- 600
--- COLLECTOR LINE	--- 600
--- RIGHT OF WAY	--- 600
--- PAVED ROAD	--- 600
--- NON LEASE LINE	--- 600
--- DRIVEWAY	--- 600
--- HORIZONTAL	--- 600
--- DIRECTIONAL DRILL	--- 600

LANDSCAPE LEGEND

- REPRESENTATIVE PLANTING TEMPLATE 1 (TYPICAL)
- REPRESENTATIVE PLANTING TEMPLATE 2 (ALTERNATIVE)

PRELIMINARY
NOT FOR CONSTRUCTION

100 0 100 200 FT
SCALE: 1" = 100'

UNDER NEW YORK STATE EDUCATION LAW ARTICLE 145 (ENGINEERING), SECTION 7209 (2), IT IS A VIOLATION OF THE LAW FOR ANY PERSON, UNLESS ACTING UNDER THE DIRECTION OF A LICENSED PROFESSIONAL ENGINEER, TO ALTER THIS DOCUMENT.

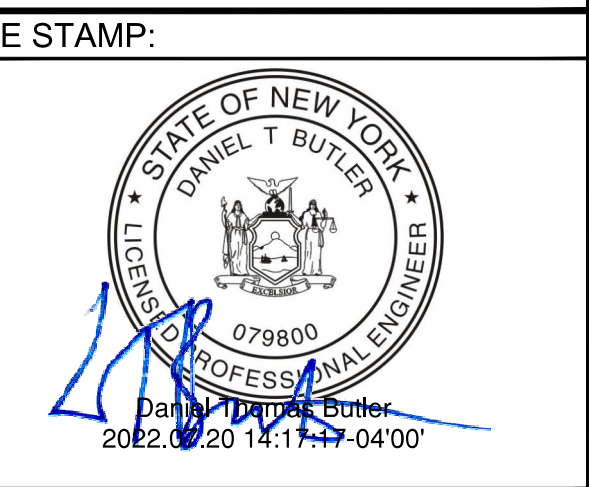

KEY PLAN:

REVISIONS:

NO.	DATE	DESCRIPTION
0	01/19/2022	DESIGN DRAWINGS
1	06/27/2022	ISSUED FOR PERMIT
2	07/20/2022	ISSUED FOR PERMIT
-	-	-
-	-	-
-	-	-
-	-	-
-	-	-
-	-	-

PROJECT TITLE:
BROOKSIDE SOLAR PROJECT

PROJECT LOCATION:
TOWNS OF BURKE AND CHATEAUGAY, NY

SHEET TITLE & DESCRIPTION:
ENLARGED LANDSCAPE PLAN

PROJ NUM:	422299
DES:	M.ROSS
DWN:	T.FIEBRANZ
CHK:	M.ROSS
APV:	-
DATE:	04/02/2021
SCALE AT 24" x 36":	-

AS NOTED
SHEET NO: PV-C.13.03 REV: 1

FOR CONTINUATION, SEE SHEET PV-C.13.06

FOR CONTINUATION, SEE SHEET PV-C.13.04

VERTICAL SCALE: 1" = 100' (SEE PLAN)
DRAWN BY: J. W. ROSS, P.E., REG. P.E. NO. 138980
CHECKED BY: M. ROSS, P.E., REG. P.E. NO. 138980
DATE: 04/02/2021
PROJECT: PV-C.13.03

FOR CONTINUATION, SEE SHEET PV-C.13.01

FOR CONTINUATION, SEE SHEET PV-C.13.02



POINT #	MITIGATION SECTION	LATITUDE	LONGITUDE
15	VM-4	N 44.929699	W 74.133207
16	VM-4	N 44.929790	W 74.131443
17	VM-4	N 44.930281	W 74.131506
18	VM-4	N 44.930277	W 74.130281

POINT #	MITIGATION SECTION	LATITUDE	LONGITUDE
22	VM-6	N 44.931293	W 74.130371
23	VM-6	N 44.933459	W 74.130358

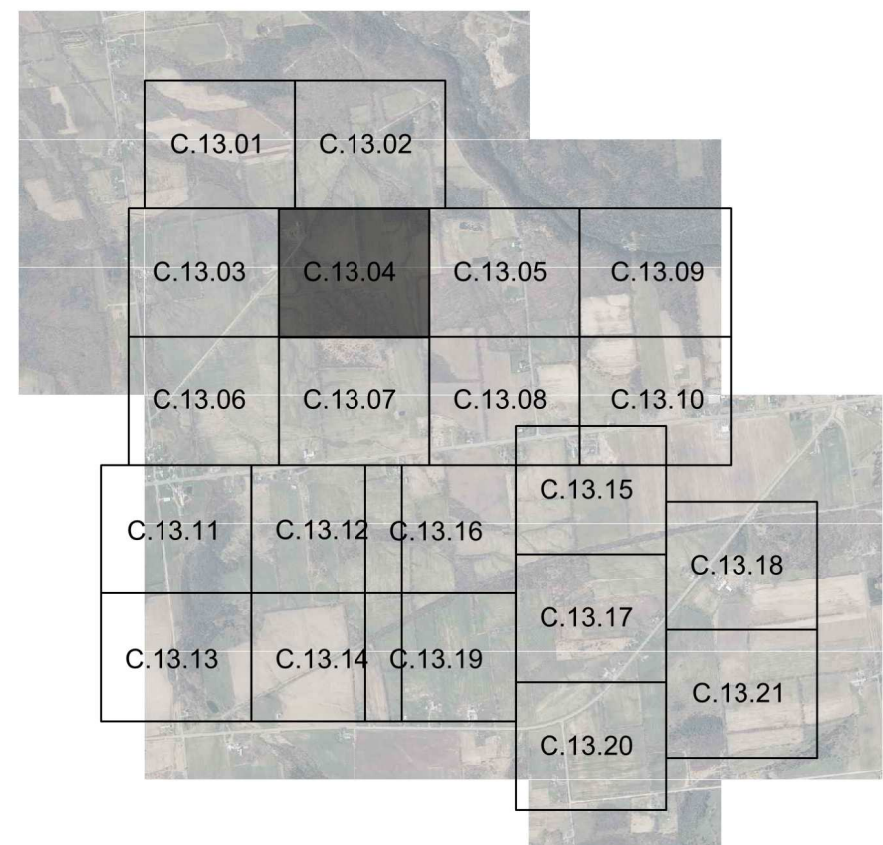

KEY MAP
SCALE: 1" = 3000'

EXISTING		PROPOSED	
---	PROPERTY BOUNDARY	---	LOD
---	94C SETBACK	---	SF
---	TOWN SETBACK	---	SF
---	LIMIT OF DISTURBANCE	---	SF
---	SOIL BOUNDARY	---	SF
---	SILT FENCE	---	SF
---	OHE	---	SF
---	OVERHEAD ELECTRIC	---	SF
---	CHAIN LINK FENCE	---	SF
---	BARBED WIRE FENCE	---	SF
---	GRAVEL ROAD	---	SF
---	BASELINE	---	SF
---	PV ARRAY	---	SF
---	EQUIPMENT PADS & BOLLARDS	---	SF
---	MINOR CONTOUR	---	SF
---	MAJOR CONTOUR	---	SF
---	WETLAND	---	SF
---	STREAM	---	SF
---	WATER SURFACE	---	SF
---	TREELINE	---	SF
---	BRUSH	---	SF
---	BUILDING	---	SF
---	STONE WALL	---	SF
---	UTILITY POLE	---	SF
---	VALVE	---	SF
---	CULVERT	---	SF
---	WETLAND ADJACENT AREA / STREAM BUFFER	---	SF
---	LAYDOWN YARD	---	SF
---	TOWN BOUNDARY	---	SF
---	COLLECTOR LINE	---	SF
---	RIGHT OF WAY	---	SF
---	PAVED ROAD	---	SF
---	NON LEASE LINE	---	SF
---	DRIVEWAY	---	SF
---	HORIZONTAL	---	SF
---	DIRECTIONAL DRILL	---	SF

LANDSCAPE LEGEND	
---	REPRESENTATIVE PLANTING TEMPLATE 1 (TYPICAL)
---	REPRESENTATIVE PLANTING TEMPLATE 2 (ALTERNATIVE)

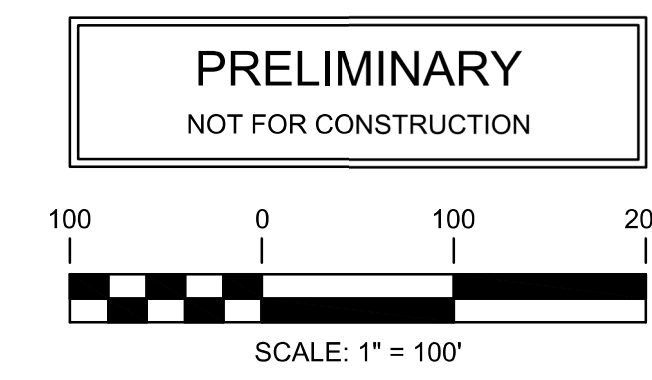

PRELIMINARY
NOT FOR CONSTRUCTION

UNDER NEW YORK STATE EDUCATION LAW ARTICLE 145 (ENGINEERING), SECTION 7209 (2), IT IS A VIOLATION OF THE LAW FOR ANY PERSON, UNLESS ACTING UNDER THE DIRECTION OF A LICENSED PROFESSIONAL ENGINEER, TO ALTER THIS DOCUMENT.

FOR CONTINUATION, SEE SHEET PV-C.13.03

FOR CONTINUATION, SEE SHEET PV-C.13.05

FOR CONTINUATION, SEE SHEET PV-C.13.07

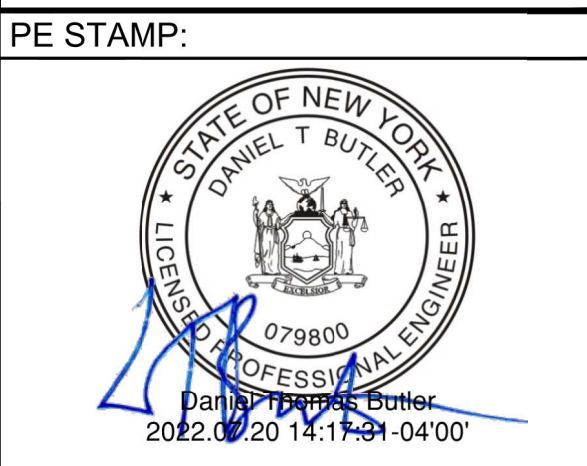

KEY PLAN:

REVISIONS:		
NO.	DATE	DESCRIPTION
0	01/19/2022	DESIGN DRAWINGS
1	06/27/2022	ISSUED FOR PERMIT
2	07/20/2022	ISSUED FOR PERMIT
-	-	-
-	-	-
-	-	-
-	-	-
-	-	-

PROJECT TITLE:
BROOKSIDE SOLAR PROJECT

PROJECT LOCATION:
TOWNS OF BURKE AND CHATEAUGAY, NY

SHEET TITLE & DESCRIPTION:
ENLARGED LANDSCAPE PLAN

PROJ NUM:	422299
DES:	M.ROSS
DWN:	T.FIEBRANZ
CHK:	M.ROSS
APV:	-
DATE:	04/02/2021
SCALE AT 24" x 36":	

AS NOTED

SHEET NO:	PV-C.13.04	REV:	1
-----------	------------	------	---

FOR CONTINUATION, SEE SHEET PV-C.13.02

AES TITLE: 21/06/2022 1:55 PM; C:\DWGFILES\2022\2022 PV-C.13.05.dwg; USER: TIEBER; PLOT: 2022 PV-C.13.05.dwg; PLOT DATE: 2/21/2022 1:55 PM; PLOT BY: TIEBER

FOR CONTINUATION, SEE SHEET PV-C.13.04

FOR CONTINUATION, SEE SHEET PV-C.13.08

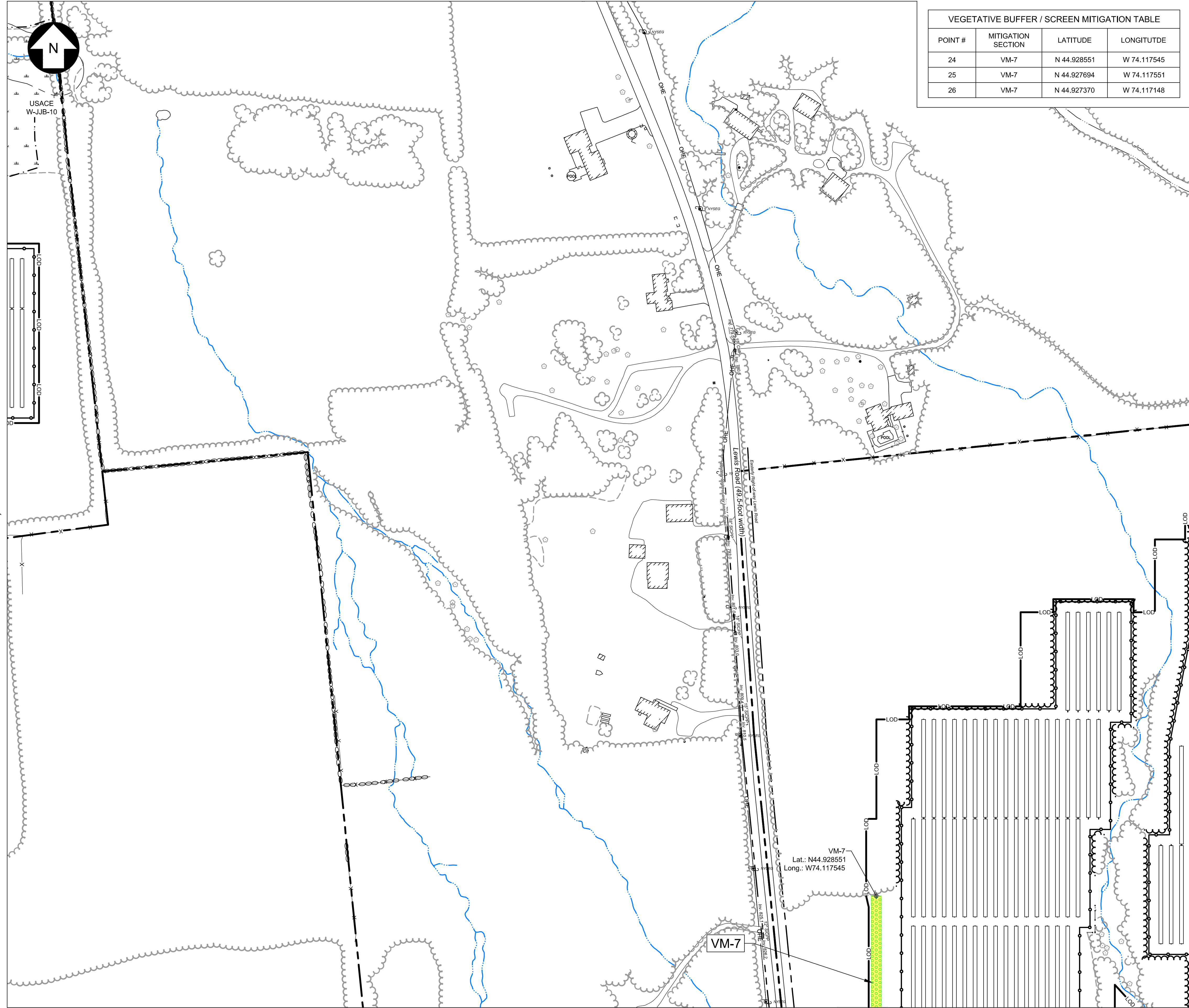

POINT #	MITIGATION SECTION	LATITUDE	LONGITUDE
24	VM-7	N 44.928551	W 74.117545
25	VM-7	N 44.927694	W 74.117551
26	VM-7	N 44.927370	W 74.117148

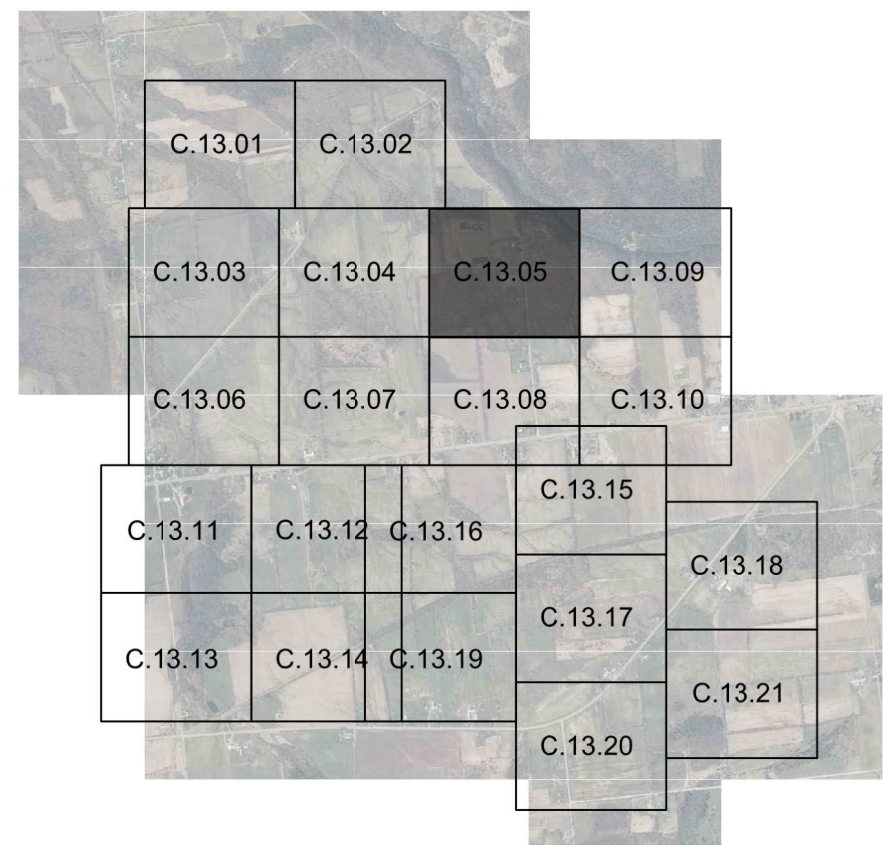

KEY MAP
SCALE: 1" = 3000'

EXISTING		PROPOSED
(---)	PROPERTY BOUNDARY	(---) LOD
(---)	94C SETBACK	(---) LOD
(---)	TOWN SETBACK	(---) LOD
(---)	LIMIT OF DISTURBANCE	(---) LOD
(---)	SOIL BOUNDARY	(---) LOD
(---)	SILT FENCE	(---) SF
(---)	OVERHEAD ELECTRIC	(---) SF
(---)	CHAIN LINK FENCE	(---) SF
(---)	BARBED WIRE FENCE	(---) SF
(---)	GRAVEL ROAD	(---)
(---)	BASILINE	(---)
(---)	PV ARRAY	(---)
(---)	EQUIPMENT PADS & BOLLARDS	(---)
(---)	MINOR CONTOUR	(---) 598
(---)	MAJOR CONTOUR	(---) 600
(---)	WETLAND	(---)
(---)	STREAM	(---)
(---)	WATER SURFACE	(---)
(---)	TREELINE	(---)
(---)	BRUSH	(---)
(---)	BUILDING	(---)
(---)	STONE WALL	(---)
(---)	UTILITY POLE	(---)
(---)	VALVE	(---)
(---)	CULVERT	(---)
(---)	WETLAND ADJACENT AREA / STREAM BUFFER	(---)
(---)	LAYDOWN YARD	(---)
(---)	TOWN BOUNDARY	(---) E1
(---)	COLLECTOR LINE	(---)
(---)	RIGHT OF WAY	(---)
(---)	PAVED ROAD	(---)
(---)	NON LEASE LINE	(---)
(---)	DRIVEWAY	(---)
(---)	HORIZONTAL	(---)
(---)	DIRECTIONAL DRILL	(---)

LANDSCAPE LEGEND

- (---) REPRESENTATIVE PLANTING TEMPLATE 1 (TYPICAL)
- (---) REPRESENTATIVE PLANTING TEMPLATE 2 (ALTERNATIVE)



PRELIMINARY
NOT FOR CONSTRUCTION

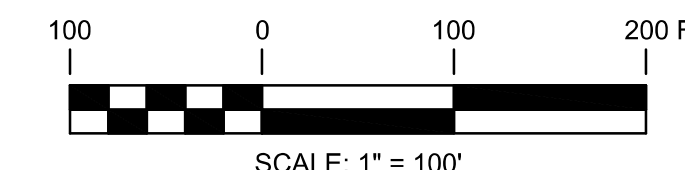

SCALE: 1" = 100'
UNDER NEW YORK STATE EDUCATION LAW ARTICLE 145 (ENGINEERING), SECTION 7209 (2), IT IS A VIOLATION OF THE LAW FOR ANY PERSON, UNLESS ACTING UNDER THE DIRECTION OF A LICENSED PROFESSIONAL ENGINEER, TO ALTER THIS DOCUMENT.



2180 South 1300 East, Suite 600
Salt Lake City, UT 84106-2749
(801) 879-3500

TRC

249 Western Avenue
Augusta, ME 04330

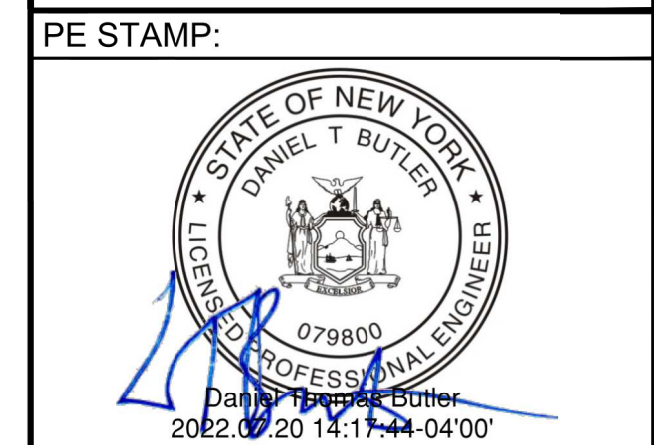

KEY PLAN:

REVISIONS:

NO.	DATE	DESCRIPTION
0	01/19/2022	DESIGN DRAWINGS
1	06/27/2022	ISSUED FOR PERMIT
2	07/20/2022	ISSUED FOR PERMIT
-	-	-
-	-	-
-	-	-
-	-	-
-	-	-

PROJECT TITLE:

BROOKSIDE SOLAR PROJECT

PROJECT LOCATION:

TOWNS OF BURKE AND CHATEAUGAY, NY

SHEET TITLE & DESCRIPTION:

ENLARGED LANDSCAPE PLAN

PROJ NUM:	422299
DES:	M.ROSS
DWN:	T.FIEBRANZ
CHK:	M.ROSS
APV:	-
DATE:	04/02/2021
SCALE AT 24" x 36":	

AS NOTED

SHEET NO: **PV-C.13.05** REV: **1**

FOR CONTINUATION, SEE SHEET PV-C.13.03

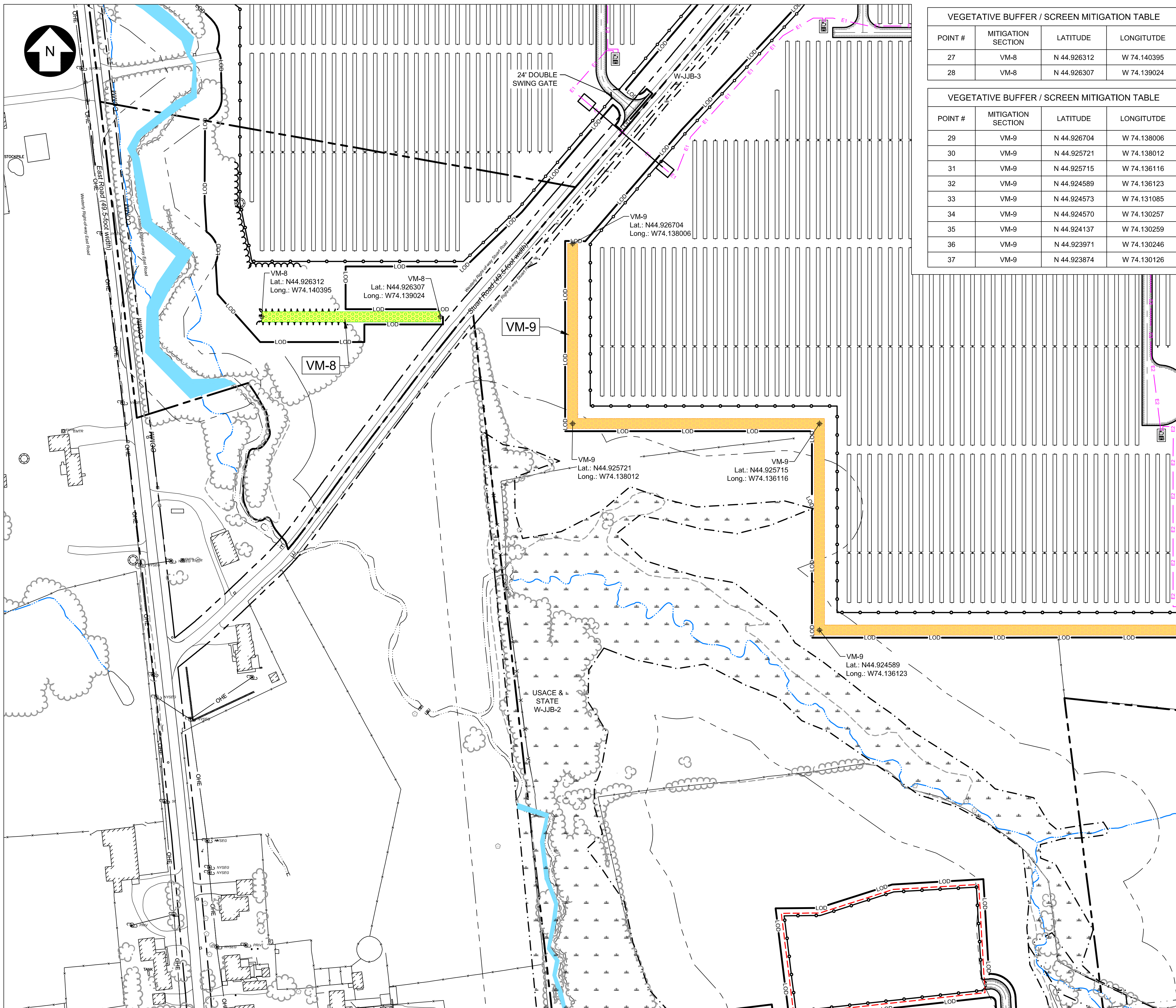

FOR CONTINUATION, SEE SHEET PV-C.13.11

FOR CONTINUATION, SEE SHEET PV-C.13.12

VEGETATIVE BUFFER / SCREEN MITIGATION TABLE			
POINT #	MITIGATION SECTION	LATITUDE	LONGITUDE
27	VM-8	N 44.926312	W 74.140395
28	VM-8	N 44.926307	W 74.139024

VEGETATIVE BUFFER / SCREEN MITIGATION TABLE			
POINT #	MITIGATION SECTION	LATITUDE	LONGITUDE
29	VM-9	N 44.926704	W 74.138006
30	VM-9	N 44.925721	W 74.138012
31	VM-9	N 44.925715	W 74.136116
32	VM-9	N 44.924589	W 74.136123
33	VM-9	N 44.924573	W 74.131085
34	VM-9	N 44.924570	W 74.130257
35	VM-9	N 44.924137	W 74.130259
36	VM-9	N 44.923971	W 74.130246
37	VM-9	N 44.923874	W 74.130126

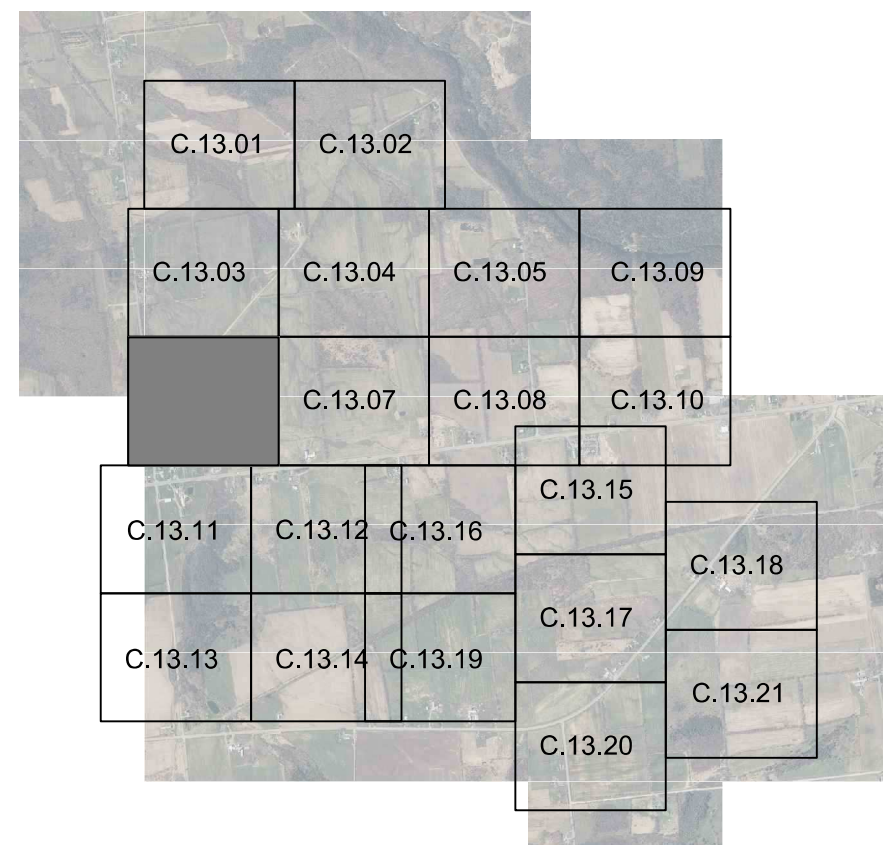

KEY MAP
SCALE: 1" = 3000'

EXISTING		PROPOSED	
---	PROPERTY BOUNDARY	---	PROPERTY BOUNDARY
---	94C SETBACK	---	94C SETBACK
---	TOWN SETBACK	---	TOWN SETBACK
---	LIMIT OF DISTURBANCE	---	LIMIT OF DISTURBANCE
---	SOIL BOUNDARY	---	SOIL BOUNDARY
---	SILT FENCE	---	SILT FENCE
---	OVERHEAD ELECTRIC	---	OVERHEAD ELECTRIC
---	CHAIN LINK FENCE	---	CHAIN LINK FENCE
---	BARBED WIRE FENCE	---	BARBED WIRE FENCE
---	GRAVEL ROAD	---	GRAVEL ROAD
---	BASELINE	---	BASELINE
---	PV ARRAY	---	PV ARRAY
---	EQUIPMENT PADS & BOLLARDS	---	EQUIPMENT PADS & BOLLARDS
---	MINOR CONTOUR	---	MINOR CONTOUR
---	MAJOR CONTOUR	---	MAJOR CONTOUR
---	WETLAND	---	WETLAND
---	STREAM	---	STREAM
---	WATER SURFACE	---	WATER SURFACE
---	TREELINE	---	TREELINE
---	BRUSH	---	BRUSH
---	BUILDING	---	BUILDING
---	STONE WALL	---	STONE WALL
---	UTILITY POLE	---	UTILITY POLE
---	VALVE	---	VALVE
---	CULVERT	---	CULVERT
---	WETLAND ADJACENT AREA / STREAM BUFFER	---	WETLAND ADJACENT AREA / STREAM BUFFER
---	LAYDOWN YARD	---	LAYDOWN YARD
---	TOWN BOUNDARY	---	TOWN BOUNDARY
---	COLLECTOR LINE	---	COLLECTOR LINE
---	RIGHT OF WAY	---	RIGHT OF WAY
---	PAVED ROAD	---	PAVED ROAD
---	NON LEASE LINE	---	NON LEASE LINE
---	DRIVEWAY	---	DRIVEWAY
---	HORIZONTAL DIRECTIONAL DRILL	---	HORIZONTAL DIRECTIONAL DRILL

LANDSCAPE LEGEND	
---	REPRESENTATIVE PLANTING TEMPLATE 1 (TYPICAL)
---	REPRESENTATIVE PLANTING TEMPLATE 2 (ALTERNATIVE)

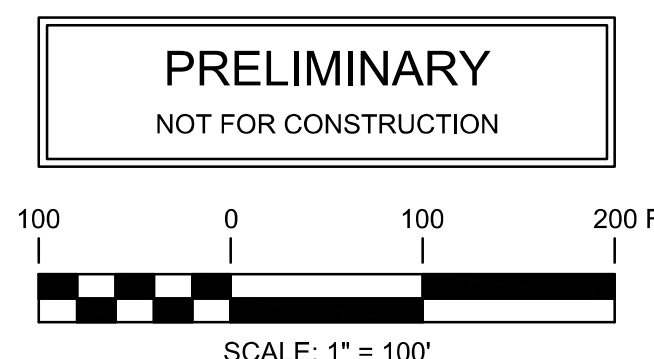

UNDER NEW YORK STATE EDUCATION LAW ARTICLE 145 (ENGINEERING), SECTION 7209 (2), IT IS A VIOLATION OF THE LAW FOR ANY PERSON, UNLESS ACTING UNDER THE DIRECTION OF A LICENSED PROFESSIONAL ENGINEER, TO ALTER THIS DOCUMENT.

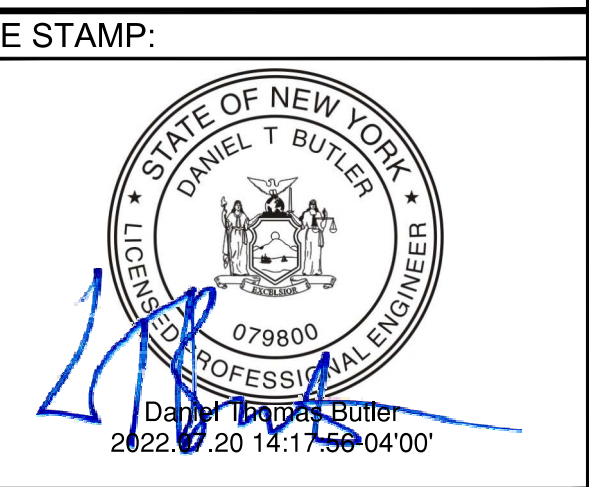

KEY PLAN:

REVISIONS:		
NO.	DATE	DESCRIPTION
0	01/19/2022	DESIGN DRAWINGS
1	06/27/2022	ISSUED FOR PERMIT
2	07/20/2022	ISSUED FOR PERMIT
-	-	-
-	-	-
-	-	-
-	-	-
-	-	-

REVISIONS:		
NO.	DATE	DESCRIPTION
0	01/19/2022	DESIGN DRAWINGS
1	06/27/2022	ISSUED FOR PERMIT
2	07/20/2022	ISSUED FOR PERMIT
-	-	-
-	-	-
-	-	-
-	-	-
-	-	-

PROJECT TITLE:

BROOKSIDE SOLAR PROJECT

PROJECT LOCATION:

TOWNS OF BURKE AND CHATEAUGAY, NY

SHEET TITLE & DESCRIPTION:

ENLARGED LANDSCAPE PLAN

PROJ NUM:	422299
DES:	M.ROSS
DWN:	T.FIEBRANZ
CHK:	M.ROSS
APV:	-
DATE:	04/02/2021
SCALE AT 24" x 36"	

AS NOTED

SHEET NO:	PV-C.13.06	REV:	1
-----------	------------	------	---

FOR CONTINUATION, SEE SHEET PV-C.13.04

POINT #	MITIGATION SECTION	LATITUDE	LONGITUDE
29	VM-9	N 44.926704	W 74.138006
30	VM-9	N 44.925721	W 74.138012
31	VM-9	N 44.925715	W 74.136116
32	VM-9	N 44.924589	W 74.136123
33	VM-9	N 44.924573	W 74.131085
34	VM-9	N 44.924570	W 74.130257
35	VM-9	N 44.924137	W 74.130259
36	VM-9	N 44.923971	W 74.130246
37	VM-9	N 44.923874	W 74.130126

POINT #	MITIGATION SECTION	LATITUDE	LONGITUDE
38	VM-10	N 44.923779	W 74.129841
39	VM-10	N 44.923769	W 74.126628
40	VM-10	N 44.923958	W 74.126387
41	VM-10	N 44.924124	W 74.126372
42	VM-10	N 44.924473	W 74.126370
43	VM-10	N 44.924470	W 74.125501
44	VM-10	N 44.925203	W 74.125496
45	VM-10	N 44.925202	W 74.125038
46	VM-10	N 44.925449	W 74.124726

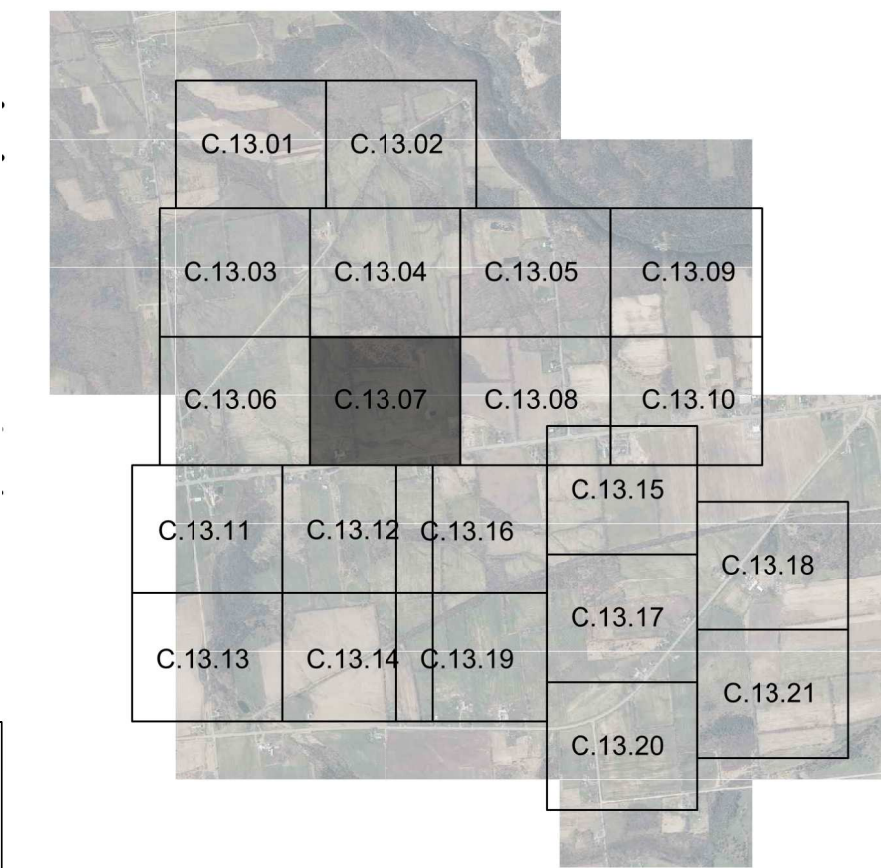

KEY MAP
SCALE: 1" = 3000'

LEGEND

EXISTING	PROPOSED
	PROPERTY BOUNDARY
	94C SETBACK
	TOWN SETBACK
	LIMIT OF DISTURBANCE
	SOIL BOUNDARY
	SILT FENCE
	OVERHEAD ELECTRIC
	CHAIN LINK FENCE
	BARBED WIRE FENCE
	GRAVEL ROAD
	BASELINE
	PV ARRAY
	EQUIPMENT PADS & BOLLARDS
	MINOR CONTOUR
	MAJOR CONTOUR
	WETLAND
	STREAM
	WATER SURFACE
	TREELINE
	BRUSH
	BUILDING
	STONE WALL
	UTILITY POLE
	VALVE
	CULVERT
	WETLAND ADJACENT AREA / STREAM BUFFER
	LAYDOWN YARD
	TOWN BOUNDARY
	COLLECTOR LINE
	RIGHT OF WAY
	PAVED ROAD
	NON LEASE LINE
	DRIVEWAY
	HORIZONTAL
	DIRECTIONAL DRILL

LANDSCAPE LEGEND

	REPRESENTATIVE PLANTING TEMPLATE 1 (TYPICAL)
	REPRESENTATIVE PLANTING TEMPLATE 2 (ALTERNATIVE)

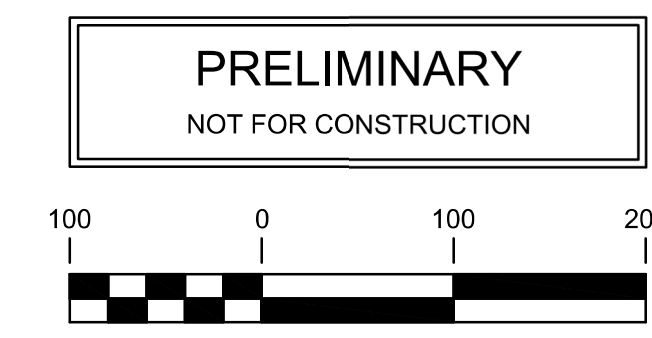

UNDER NEW YORK STATE EDUCATION LAW ARTICLE 145 (ENGINEERING), SECTION 7209 (2), IT IS A VIOLATION OF THE LAW FOR ANY PERSON, UNLESS ACTING UNDER THE DIRECTION OF A LICENSED PROFESSIONAL ENGINEER, TO ALTER THIS DOCUMENT.

FOR CONTINUATION, SEE SHEET PV-C.13.06

FOR CONTINUATION, SEE SHEET PV-C.13.08

FOR CONTINUATION, SEE SHEET PV-C.13.12

FOR CONTINUATION, SEE SHEET PV-C.13.16

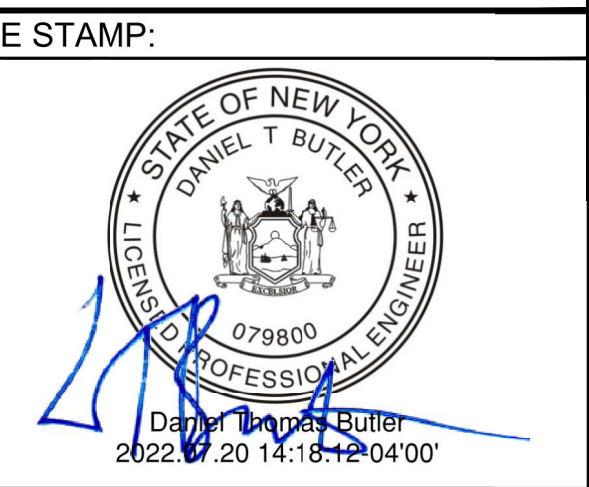

KEY PLAN:

REVISIONS:

NO.	DATE	DESCRIPTION
0	01/19/2022	DESIGN DRAWINGS
1	06/27/2022	ISSUED FOR PERMIT
2	07/20/2022	ISSUED FOR PERMIT
-	-	-
-	-	-
-	-	-
-	-	-
-	-	-

PROJECT TITLE:

BROOKSIDE SOLAR PROJECT

PROJECT LOCATION:

TOWNS OF BURKE AND CHATEAUGAY, NY

SHEET TITLE & DESCRIPTION:

ENLARGED LANDSCAPE PLAN

PROJ. NUM:	422299
DES:	M.ROSS
DWN:	T.FIEBRANZ
CHK:	M.ROSS
APV:	-
DATE:	04/02/2021
SCALE AT 24" x 36":	-

AS NOTED

SHEET NO:	REV:
PV-C.13.07	1

FOR CONTINUATION, SEE SHEET PV-C.13.05

VEGETATIVE BUFFER / SCREEN MITIGATION TABLE			
POINT #	MITIGATION SECTION	LATITUDE	LONGITUDE
24	VM-7	N 44.928551	W 74.117545
25	VM-7	N 44.927694	W 74.117551
26	VM-7	N 44.927370	W 74.117148

VEGETATIVE BUFFER / SCREEN MITIGATION TABLE			
POINT #	MITIGATION SECTION	LATITUDE	LONGITUDE
47	VM-11	N 44.927213	W 74.117151
48	VM-11	N 44.927142	W 74.117145
49	VM-11	N 44.926968	W 74.117002
50	VM-11	N 44.926205	W 74.117008
51	VM-11	N 44.926149	W 74.117087
52	VM-11	N 44.925372	W 74.117092
53	VM-11	N 44.925170	W 74.116840
54	VM-11	N 44.925169	W 74.116774
55	VM-11	N 44.925088	W 74.116763
56	VM-11	N 44.924897	W 74.116526
57	VM-11	N 44.924896	W 74.116056

VEGETATIVE BUFFER / SCREEN MITIGATION TABLE			
POINT #	MITIGATION SECTION	LATITUDE	LONGITUDE
58	VM-12	N 44.924895	W 74.115826
59	VM-12	N 44.924892	W 74.114969
60	VM-12	N 44.925025	W 74.114647
61	VM-12	N 44.925113	W 74.114253
62	VM-12	N 44.925238	W 74.113848
63	VM-12	N 44.925423	W 74.113614
64	VM-12	N 44.925588	W 74.113598
65	VM-12	N 44.926091	W 74.113595
66	VM-12	N 44.925799	W 74.112503
67	VM-12	N 44.925219	W 74.111824
68	VM-12	N 44.925004	W 74.111804

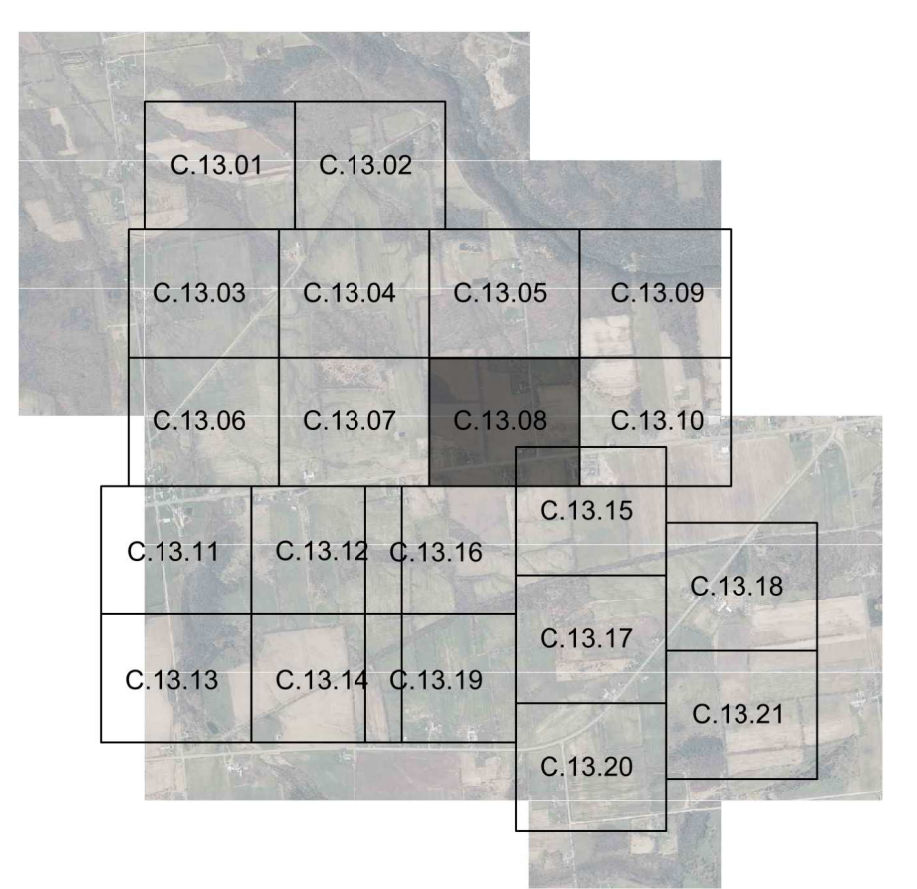
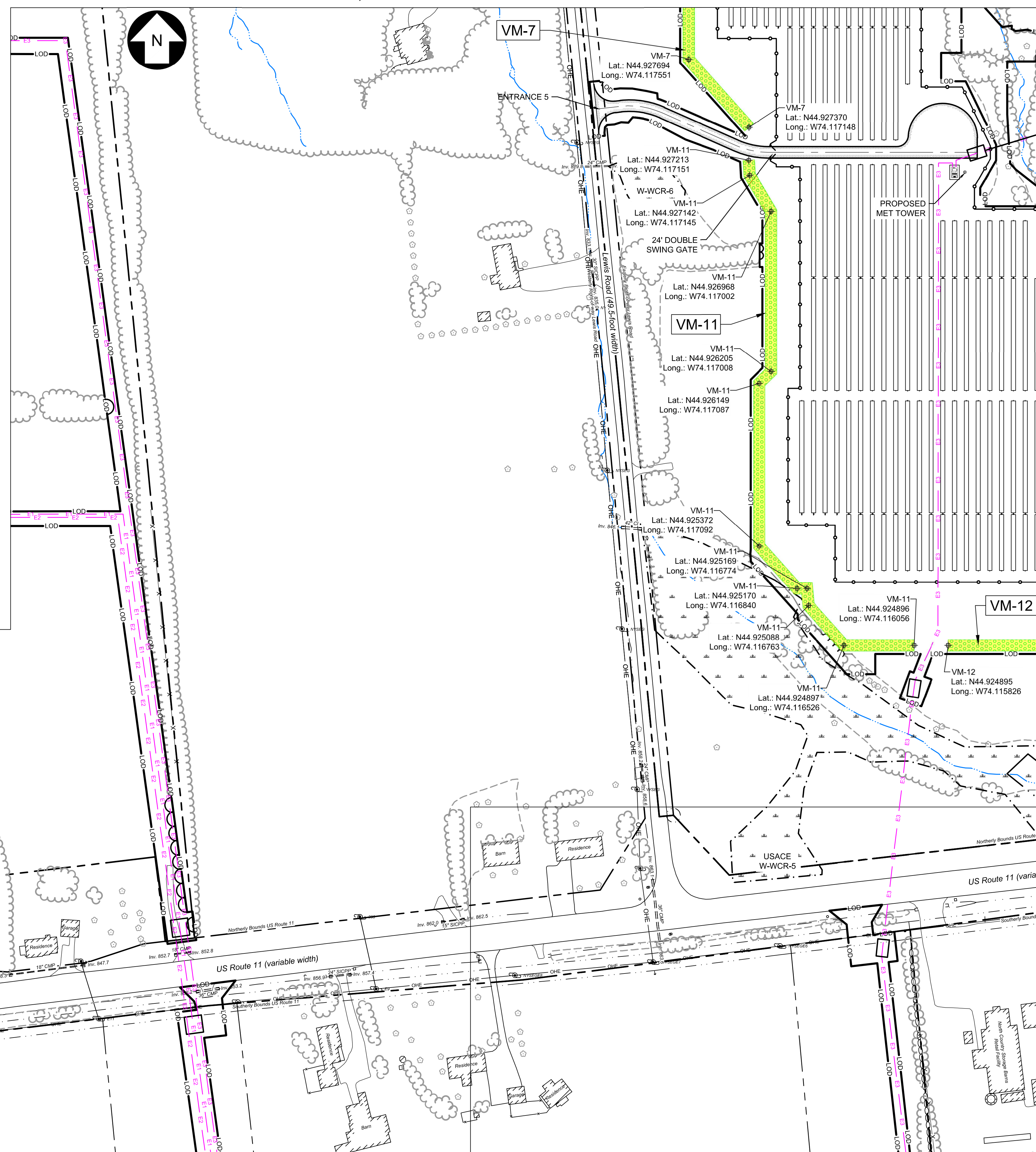

KEY MAP
SCALE: 1" = 3000'

LEGEND

EXISTING	PROPOSED
--- PROPERTY BOUNDARY	--- 94C SETBACK
--- TOWN SETBACK	--- LIMIT OF DISTURBANCE
--- SOIL BOUNDARY	--- SOIL BOUNDARY
--- SILT FENCE	--- SF
--- OHE	--- OVERHEAD ELECTRIC
--- CHAIN LINK FENCE	--- CHAIN LINK FENCE
--- BARBED WIRE FENCE	--- BARBED WIRE FENCE
--- GRAVEL ROAD	--- GRAVEL ROAD
--- BASELINE	--- BASELINE
--- PV ARRAY	--- PV ARRAY
--- EQUIPMENT PADS & BOLLARDS	--- EQUIPMENT PADS & BOLLARDS
--- 598 MINOR CONTOUR	--- 598 MINOR CONTOUR
--- 600 MAJOR CONTOUR	--- 600 MAJOR CONTOUR
--- WETLAND	--- WETLAND
--- STREAM	--- STREAM
--- WATER SURFACE	--- WATER SURFACE
--- TREELINE	--- TREELINE
--- BRUSH	--- BRUSH
--- BUILDING	--- BUILDING
--- STONE WALL	--- STONE WALL
--- UTILITY POLE	--- UTILITY POLE
--- VALVE	--- VALVE
--- CULVERT	--- CULVERT
--- WETLAND ADJACENT AREA / STREAM BUFFER	--- WETLAND ADJACENT AREA / STREAM BUFFER
--- LAYDOWN YARD	--- LAYDOWN YARD
--- TOWN BOUNDARY	--- TOWN BOUNDARY
--- COLLECTOR LINE	--- COLLECTOR LINE
--- RIGHT OF WAY	--- RIGHT OF WAY
--- PAVED ROAD	--- PAVED ROAD
--- NON LEASE LINE	--- NON LEASE LINE
--- DRIVEWAY	--- DRIVEWAY
--- HORIZONTAL	--- HORIZONTAL
--- DIRECTIONAL DRILL	--- DIRECTIONAL DRILL

LANDSCAPE LEGEND

--- REPRESENTATIVE PLANTING TEMPLATE 1 (TYPICAL)

--- REPRESENTATIVE PLANTING TEMPLATE 2 (ALTERNATIVE)

PRELIMINARY
NOT FOR CONSTRUCTION

100 0 100 200 FT
SCALE: 1" = 100'

UNDER NEW YORK STATE EDUCATION LAW ARTICLE 145 (ENGINEERING), SECTION 7209 (2), IT IS A VIOLATION OF THE LAW FOR ANY PERSON, UNLESS ACTING UNDER THE DIRECTION OF A LICENSED PROFESSIONAL ENGINEER, TO ALTER THIS DOCUMENT.

FOR CONTINUATION, SEE SHEET PV-C.13.07

FOR CONTINUATION, SEE SHEET PV-C.13.10

FOR CONTINUATION, SEE SHEET PV-C.13.16

FOR CONTINUATION, SEE SHEET PV-C.13.15



249 Western Avenue
Augusta, ME 04330



KEY PLAN:

REVISIONS:		
NO.	DATE	DESCRIPTION
0	01/19/2022	DESIGN DRAWINGS
1	06/27/2022	ISSUED FOR PERMIT
2	07/20/2022	ISSUED FOR PERMIT
-	-	-
-	-	-
-	-	-
-	-	-

PROJECT TITLE:
BROOKSIDE SOLAR PROJECT

PROJECT LOCATION:
TOWNS OF BURKE AND CHATEAUGAY, NY

SHEET TITLE & DESCRIPTION:
ENLARGED LANDSCAPE PLAN

PROJ NUM:	422299
DES:	M.ROSS
DWN:	T.FIEBRANZ
CHK:	M.ROSS
APV:	-
DATE:	04/02/2021
SCALE AT 24" x 36":	

AS NOTED

SHEET NO:	PV-C.13.08	REV:	1
-----------	------------	------	---

FOR CONTINUATION, SEE SHEET PV-C.13.09

FOR CONTINUATION, SEE SHEET PV-C.13.08

FOR CONTINUATION, SEE SHEET PV-C.13.15

VERTICAL: 7:15:00, 1:5:00
DRAWN BY: M.ROSS
CHECKED BY: T.FIEBRANZ
DATE: 04/02/2021

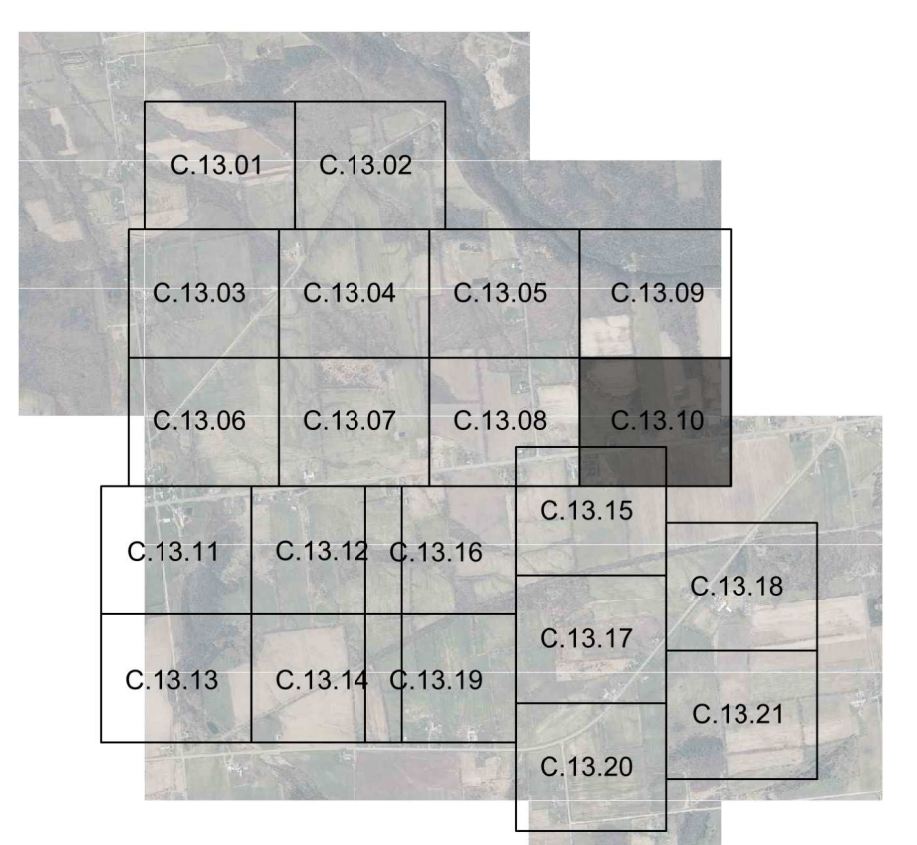
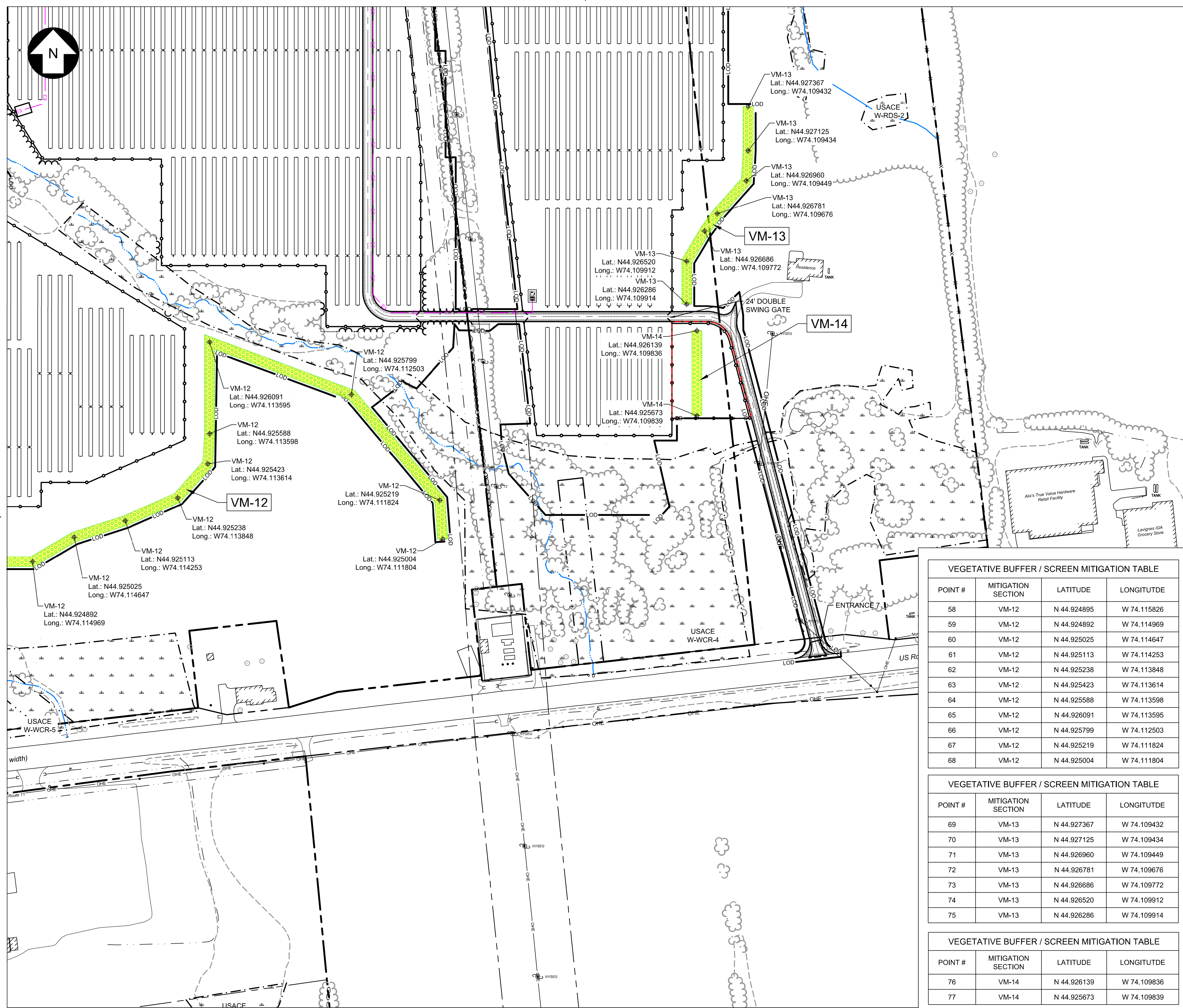

KEY MAP
SCALE: 1" = 3000'

LEGEND

EXISTING

- PROPERTY BOUNDARY
- 94C SETBACK
- TOWN SETBACK
- LIMIT OF DISTURBANCE
- SOIL BOUNDARY
- SILT FENCE
- OHE
- OVERHEAD ELECTRIC
- CHAIN LINK FENCE
- BARBED WIRE FENCE
- GRAVEL ROAD
- BASILINE
- PV ARRAY

PROPOSED

- LOD
- SF
- X
- X

EQUIPMENT PADS & BOLLARDS

- MINOR CONTOUR (598)
- MAJOR CONTOUR (600)
- WETLAND
- STREAM
- WATER SURFACE
- TREELINE
- BRUSH
- BUILDING
- STONE WALL
- UTILITY POLE
- VALVE
- CULVERT
- WETLAND ADJACENT AREA / STREAM BUFFER
- LAYDOWN YARD
- TOWN BOUNDARY
- COLLECTOR LINE
- RIGHT OF WAY
- PAVED ROAD
- NON LEASE LINE
- DRIVEWAY
- HORIZONTAL DIRECTIONAL DRILL

LANDSCAPE LEGEND

- REPRESENTATIVE PLANTING TEMPLATE 1 (TYPICAL)
- REPRESENTATIVE PLANTING TEMPLATE 2 (ALTERNATIVE)

VEGETATIVE BUFFER / SCREEN MITIGATION TABLE

POINT #	MITIGATION SECTION	LATITUDE	LONGITUDE
58	VM-12	N 44.924895	W 74.115826
59	VM-12	N 44.924892	W 74.114969
60	VM-12	N 44.925025	W 74.114647
61	VM-12	N 44.925113	W 74.114253
62	VM-12	N 44.925238	W 74.113848
63	VM-12	N 44.925423	W 74.113614
64	VM-12	N 44.925588	W 74.113598
65	VM-12	N 44.926091	W 74.113595
66	VM-12	N 44.925799	W 74.112503
67	VM-12	N 44.925219	W 74.111824
68	VM-12	N 44.925004	W 74.111804

VEGETATIVE BUFFER / SCREEN MITIGATION TABLE

POINT #	MITIGATION SECTION	LATITUDE	LONGITUDE
69	VM-13	N 44.927367	W 74.109432
70	VM-13	N 44.927125	W 74.109434
71	VM-13	N 44.926960	W 74.109449
72	VM-13	N 44.926781	W 74.109676
73	VM-13	N 44.926686	W 74.109772
74	VM-13	N 44.926520	W 74.109912
75	VM-13	N 44.926286	W 74.109914

VEGETATIVE BUFFER / SCREEN MITIGATION TABLE

POINT #	MITIGATION SECTION	LATITUDE	LONGITUDE
76	VM-14	N 44.926139	W 74.109836
77	VM-14	N 44.925673	W 74.109839

PRELIMINARY
NOT FOR CONSTRUCTION

Call 811
before you dig

100 0 100 200 FT
SCALE: 1" = 100'

UNDER NEW YORK STATE EDUCATION LAW ARTICLE 145 (ENGINEERING), SECTION 7209 (2), IT IS A VIOLATION OF THE LAW FOR ANY PERSON, UNLESS ACTING UNDER THE DIRECTION OF A LICENSED PROFESSIONAL ENGINEER, TO ALTER THIS DOCUMENT.

aes
2180 South 1300 East, Suite 600
Salt Lake City, UT 84106-2749
(801) 879-3500

TRC
249 Western Avenue
Augusta, ME 04330

PE STAMP:
STATE OF NEW YORK
DANIEL T. BUTLER
LICENSED PROFESSIONAL ENGINEER
2022.07.05 14:16:51-04'00"

KEY PLAN:

REVISIONS:

NO.	DATE	DESCRIPTION
0	01/19/2022	DESIGN DRAWINGS
1	06/27/2022	ISSUED FOR PERMIT
2	07/20/2022	ISSUED FOR PERMIT

PROJECT TITLE:
BROOKSIDE SOLAR PROJECT

PROJECT LOCATION:
TOWNS OF BURKE AND CHATEAUGAY, NY

SHEET TITLE & DESCRIPTION:
ENLARGED LANDSCAPE PLAN

PROJ. NUM.: 422299
DES.: M.ROSS
DWN.: T.FIEBRANZ
CHK.: M.ROSS
APV.:
DATE: 04/02/2021
SCALE AT 24" x 36":

AS NOTED

SHEET NO.: PV-C.13.10 REV: 1

FOR CONTINUATION, SEE SHEET PV-C.13.06

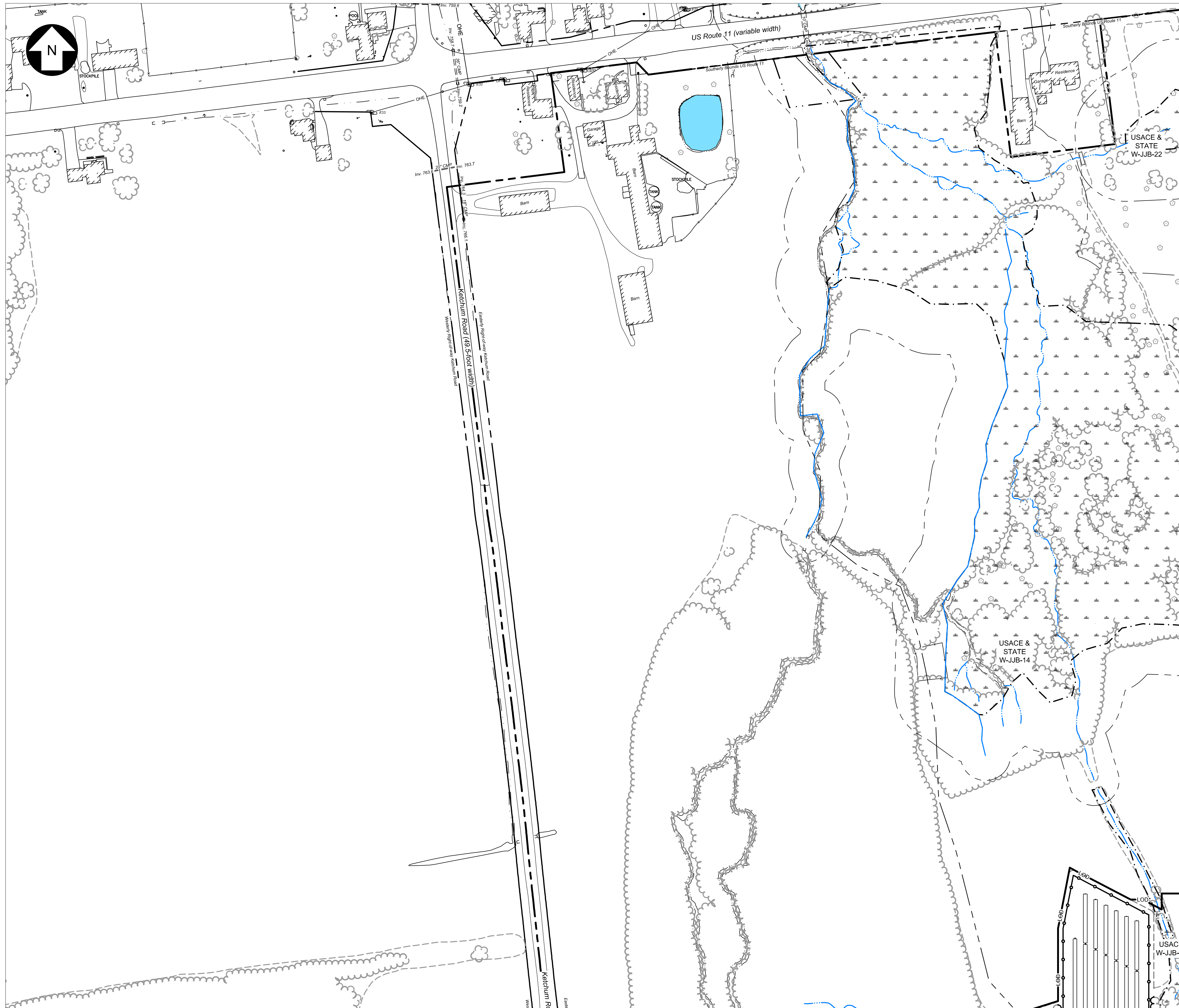

FOR CONTINUATION, SEE SHEET PV-C.13.13

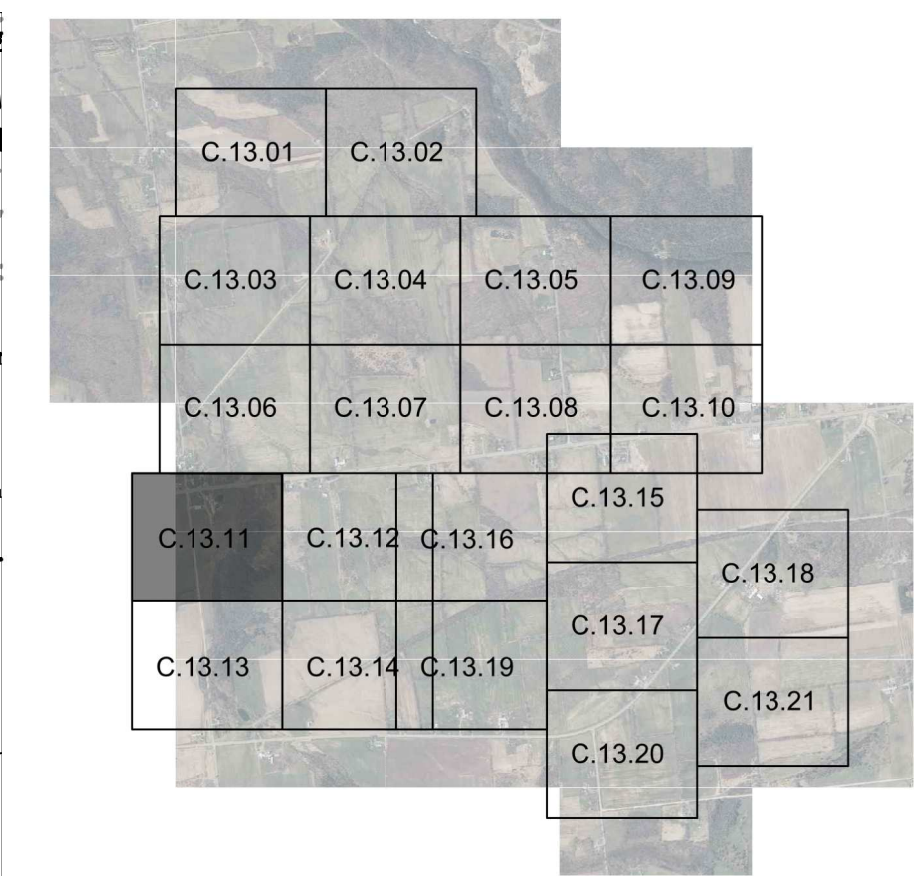

KEY MAP
SCALE: 1" = 3000'

LEGEND

EXISTING	PROPOSED
--- PROPERTY BOUNDARY	--- LOD
--- 94C SETBACK	--- SF
--- TOWN SETBACK	--- SF
--- LIMIT OF DISTURBANCE	--- SF
--- SOIL BOUNDARY	---
--- SILT FENCE	---
--- OHE	--- OVERHEAD ELECTRIC
--- CHAIN LINK FENCE	--- CHAIN LINK FENCE
--- BARBED WIRE FENCE	--- BARBED WIRE FENCE
--- GRAVEL ROAD	---
--- BASELINE	---
--- PV ARRAY	---
--- EQUIPMENT PADS & BOLLARDS	---
--- MINOR CONTOUR	--- 598
--- MAJOR CONTOUR	--- 600
--- WETLAND	---
--- STREAM	---
--- WATER SURFACE	---
--- TREELINE	---
--- BRUSH	---
--- BUILDING	---
--- STONE WALL	---
--- UTILITY POLE	---
--- VALVE	---
--- CULVERT	---
--- WETLAND ADJACENT AREA / STREAM BUFFER	---
--- LAYDOWN YARD	---
--- TOWN BOUNDARY	---
--- COLLECTOR LINE	---
--- RIGHT OF WAY	---
--- PAVED ROAD	---
--- NON LEASE LINE	---
--- DRIVEWAY	---
--- HORIZONTAL DIRECTIONAL DRILL	---

LANDSCAPE LEGEND

--- REPRESENTATIVE PLANTING TEMPLATE 1 (TYPICAL)
--- REPRESENTATIVE PLANTING TEMPLATE 2 (ALTERNATIVE)

Call 811
before you dig

PRELIMINARY
NOT FOR CONSTRUCTION

SCALE: 1" = 100'

UNDER NEW YORK STATE EDUCATION LAW ARTICLE 145 (ENGINEERING), SECTION 7209 (2), IT IS A VIOLATION OF THE LAW FOR ANY PERSON, UNLESS ACTING UNDER THE DIRECTION OF A LICENSED PROFESSIONAL ENGINEER, TO ALTER THIS DOCUMENT.

aes
2180 South 1300 East, Suite 600
Salt Lake City, UT 84106-2749
(801) 879-3500

TRC
249 Western Avenue
Augusta, ME 04330

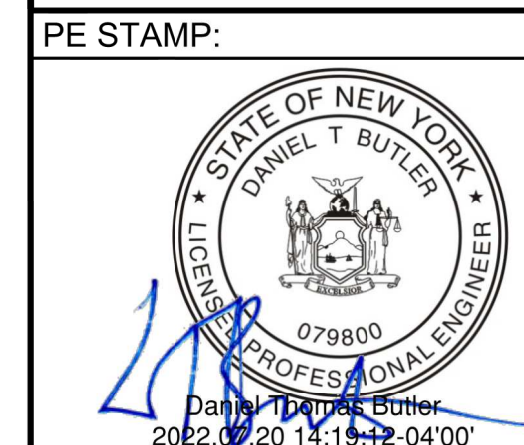

KEY PLAN:

REVISIONS:

NO.	DATE	DESCRIPTION
0	01/19/2022	DESIGN DRAWINGS
1	06/27/2022	ISSUED FOR PERMIT
2	07/20/2022	ISSUED FOR PERMIT
-	-	-
-	-	-
-	-	-
-	-	-

PROJECT TITLE:

BROOKSIDE SOLAR PROJECT

PROJECT LOCATION:

TOWNS OF BURKE AND CHATEAUGAY, NY

SHEET TITLE & DESCRIPTION:

ENLARGED LANDSCAPE PLAN

PROJ NUM:	422299
DES:	M.ROSS
DWN:	T.FIEBRANZ
CHK:	M.ROSS
APV:	-
DATE:	04/02/2021
SCALE AT 24" x 36":	

AS NOTED

SHEET NO:	PV-C.13.11	REV:	1
-----------	------------	------	---

FOR CONTINUATION, SEE SHEET PV-C.13.06

FOR CONTINUATION, SEE SHEET PV-C.13.07

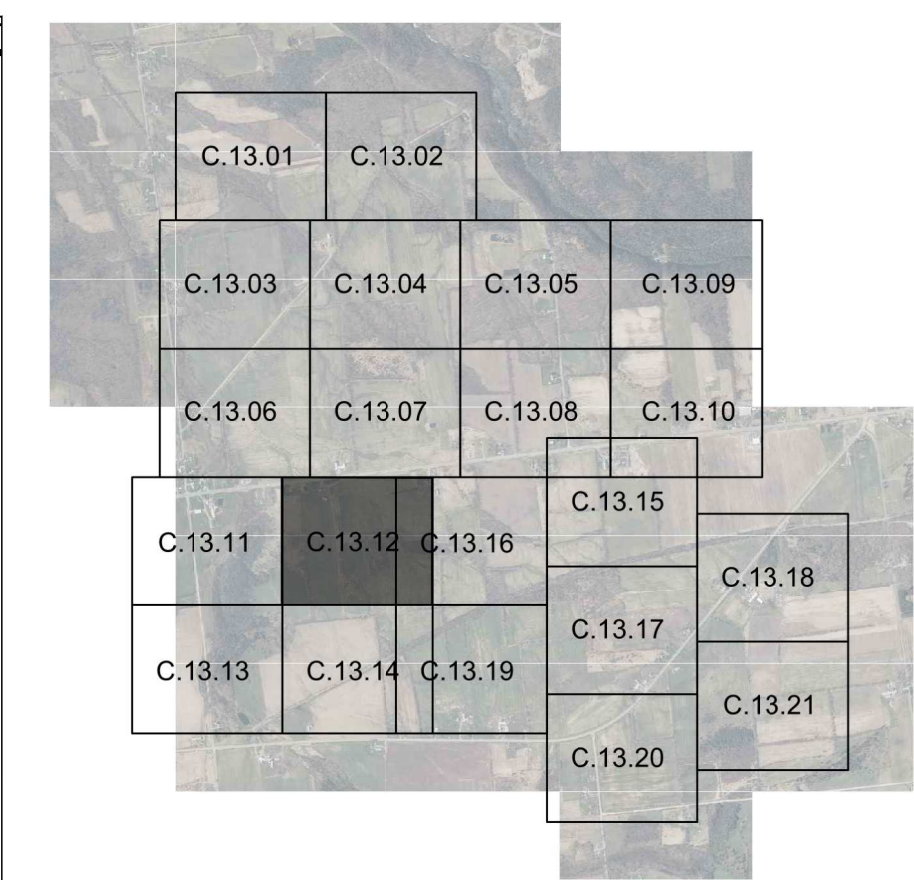
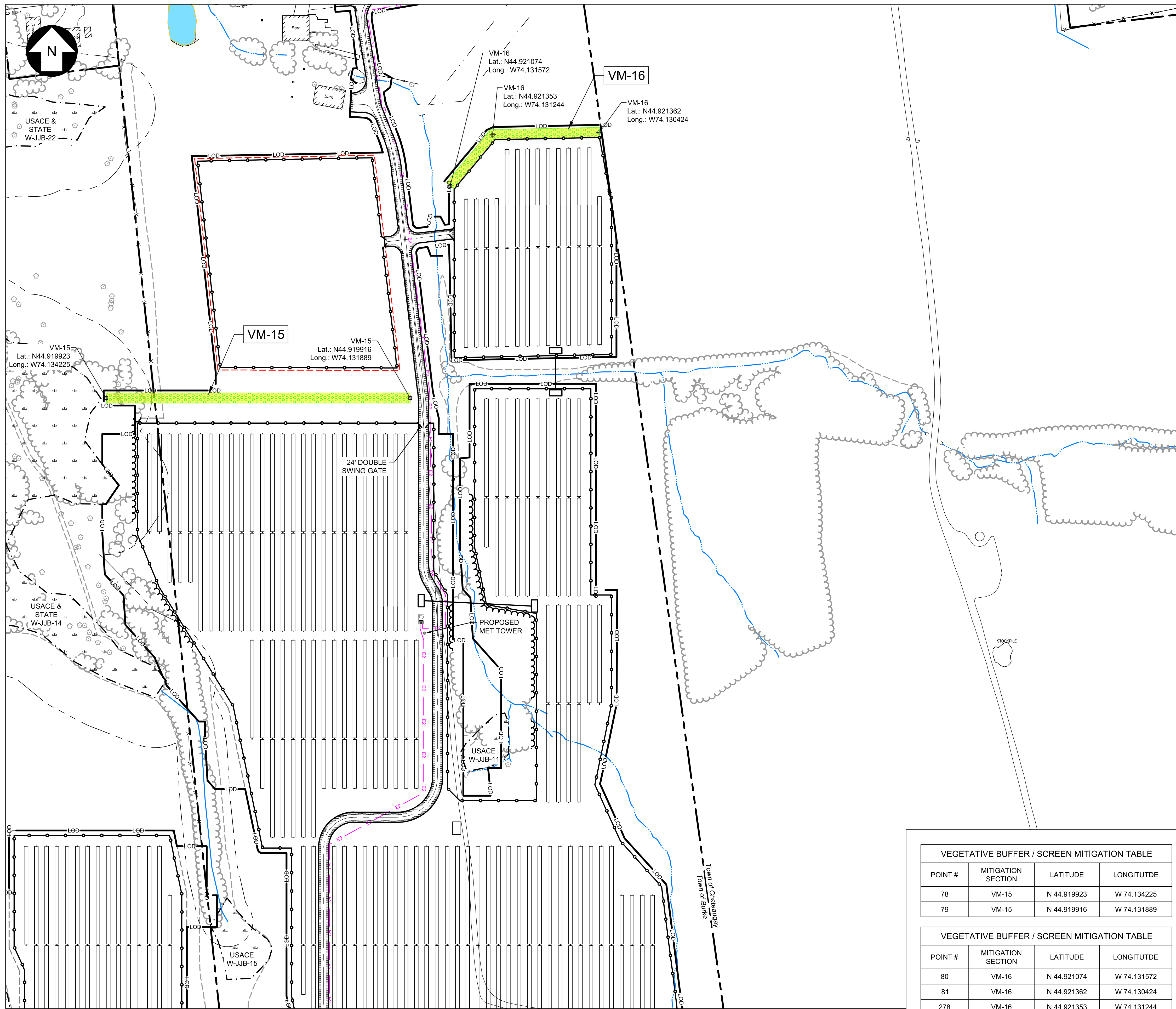

KEY MAP
SCALE: 1" = 3000'

EXISTING		PROPOSED
- - - -	PROPERTY BOUNDARY	---
---	94C SETBACK	---
---	TOWN SETBACK	---
- - - -	LIMIT OF DISTURBANCE	LOD
- - - -	SOIL BOUNDARY	- - - -
- - - -	SILT FENCE	SF
---	OHE	---
---	OVERHEAD ELECTRIC	---
---	CHAIN LINK FENCE	---
---	BARBED WIRE FENCE	---
---	GRAVEL ROAD	---
---	BASELINE	---
---	PV ARRAY	---
EQUIPMENT PADS & BOLLARDS		
- - - -	MINOR CONTOUR	598
- - - -	MAJOR CONTOUR	600
---	WETLAND	---
---	STREAM	---
---	WATER SURFACE	---
---	TREELINE	---
---	BRUSH	---
---	BUILDING	---
---	STONE WALL	---
---	UTILITY POLE	---
---	VALVE	---
---	CULVERT	---
---	WETLAND ADJACENT AREA / STREAM BUFFER	---
---	LAYDOWN YARD	---
---	TOWN BOUNDARY	---
---	COLLECTOR LINE	E1
---	RIGHT OF WAY	---
---	PAVED ROAD	---
---	NON LEASE LINE	---
---	DRIVEWAY	---
---	HORIZONTAL DIRECTIONAL DRILL	---

LANDSCAPE LEGEND

REPRESENTATIVE PLANTING TEMPLATE 1 (TYPICAL)

REPRESENTATIVE PLANTING TEMPLATE 2 (ALTERNATIVE)

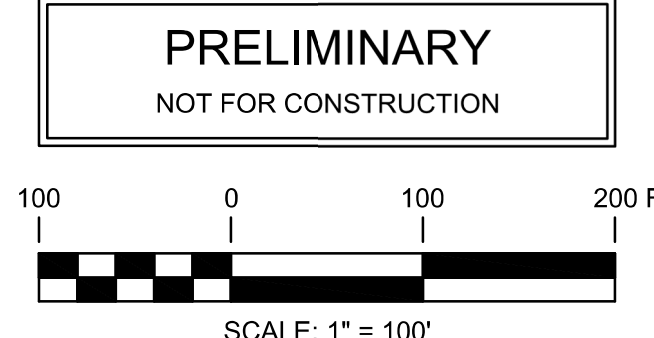

PRELIMINARY
NOT FOR CONSTRUCTION

UNDER NEW YORK STATE EDUCATION LAW ARTICLE 145 (ENGINEERING), SECTION 7209 (2), IT IS A VIOLATION OF THE LAW FOR ANY PERSON, UNLESS ACTING UNDER THE DIRECTION OF A LICENSED PROFESSIONAL ENGINEER, TO ALTER THIS DOCUMENT.

POINT #	MITIGATION SECTION	LATITUDE	LONGITUTDE
78	VM-15	N 44.919923	W 74.134225
79	VM-15	N 44.919916	W 74.131889

POINT #	MITIGATION SECTION	LATITUDE	LONGITUTDE
80	VM-16	N 44.921074	W 74.131572
81	VM-16	N 44.921362	W 74.130424
278	VM-16	N 44.921353	W 74.131244

FOR CONTINUATION, SEE SHEET PV-C.13.11

FOR CONTINUATION, SEE SHEET PV-C.13.16

FOR CONTINUATION, SEE SHEET PV-C.13.14



2180 South 1300 East, Suite 600
Salt Lake City, UT 84106-2749
(801) 879-3500



249 Western Avenue
Augusta, ME 04330

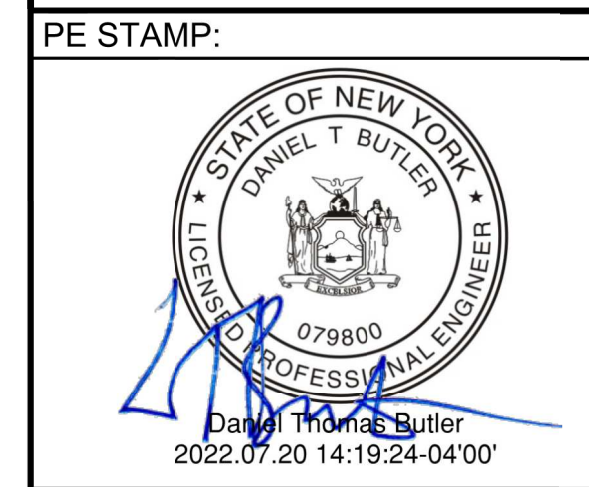

KEY PLAN:

REVISIONS:

NO.	DATE	DESCRIPTION
0	01/19/2022	DESIGN DRAWINGS
1	06/27/2022	ISSUED FOR PERMIT
2	07/20/2022	ISSUED FOR PERMIT
-	-	-
-	-	-
-	-	-
-	-	-

PROJECT TITLE:

BROOKSIDE SOLAR PROJECT

PROJECT LOCATION:

TOWNS OF BURKE AND CHATEAUGAY, NY

SHEET TITLE & DESCRIPTION:

ENLARGED LANDSCAPE PLAN

PROJ. NUM:	422299
DES:	M.ROSS
DWN:	T.FIEBRANZ
CHK:	M.ROSS
APV:	-
DATE:	04/02/2021
SCALE AT 24" x 36":	

SHEET NO:	NONE	REV:	1
PV-C.13.12			