



Consolidated Edison Company of New York, Inc.

# Request for Proposal

---

**Non-Wires Solutions to Provide Demand Side  
Management for Subtransmission and Distribution  
System Load Relief**

***Water Street Cooling Project  
Williamsburg Primary Feeder Relief Project  
Plymouth Street Cooling Project***

---

**ISSUED: OCTOBER 31, 2017**

**SUBMISSION DEADLINE: JANUARY 12, 2018**

**LAST UPDATED: OCTOBER 31, 2017**

# Table of Contents

---

CONSOLIDATED EDISON COMPANY OF NEW YORK, INC. ....	1
<b>INTRODUCTION .....</b>	<b>5</b>
BACKGROUND .....	5
DEFINITIONS.....	5
RFP PURPOSE .....	5
NWS HIGH LEVEL PROCESS .....	6
NWS PROJECT DESCRIPTIONS .....	7
<b>NWS RESPONSE REQUIREMENTS .....</b>	<b>7</b>
PROPOSED SOLUTION DESCRIPTION .....	8
PROJECT SCHEDULE AND ACQUISITION PLAN .....	8
DETAILED COSTS ASSOCIATED WITH PROPOSED SOLUTION .....	9
RISKS, CHALLENGES, COMMUNITY IMPACTS .....	9
PROFESSIONAL BACKGROUND AND EXPERIENCE WITH THE PROPOSED SOLUTION .....	9
NWS QUESTIONNAIRE.....	10
<b>PROPOSAL EVALUATION APPROACH .....</b>	<b>10</b>
PROPOSAL CRITERIA.....	11
<b>INSTRUCTIONS TO RESPONDENT .....</b>	<b>12</b>
RFP SCHEDULE .....	12
CONTACT INFORMATION AND QUESTIONS.....	12
PROPOSAL SUBMITTAL INSTRUCTIONS .....	13
PROPOSAL RESPONSE FORMAT .....	13
<i>Cover Letter</i> .....	14
<i>Respondent Checklist</i> .....	14
<i>Table of Contents</i> .....	14
<i>Executive Summary</i> .....	14
<i>Proposal</i> .....	14
<i>Assumptions &amp; Exceptions</i> .....	15
<i>Glossary of Terms</i> .....	15
<i>Appendix</i> .....	15
<i>Non-Wires Solution Questionnaire</i> .....	15
<b>RFP TERMS AND CONDITIONS .....</b>	<b>15</b>
QUALIFICATIONS OF RESPONDENTS.....	16
PROPRIETARY INFORMATION .....	16
COST OF PROPOSAL PREPARATION.....	16
RIGHT TO REJECT .....	16
REVISION TO THE RFP .....	16
BASIS OF PROPOSAL AWARD .....	17
DURATION OF THE CONTRACT.....	17

<b>NWS PROGRAM AGREEMENT .....</b>	<b>17</b>
UNDERPERFORMANCE .....	17
SECURITY .....	17
SUBCONTRACTING AND ASSIGNMENT .....	17
<b>APPENDIX: .....</b>	<b>18</b>
A. WATER STREET COOLING PROJECT .....	18
<i>Project Description</i> .....	18
<i>Area of Need</i> .....	18
<i>Overload Profiles</i> .....	21
<i>Customer Profile</i> .....	21
B. WILLIAMSBURG FEEDER PROJECT .....	23
<i>Project Description</i> .....	23
<i>Area of Need</i> .....	23
<i>Overload Profiles</i> .....	25
<i>Customer Demographic Profile</i> .....	25
C. PLYMOUTH STREET COOLING PROJECT (CUSTOMER-SITED SOLUTION) – BROOKLYN, NY .....	26
<i>Project Description</i> .....	26
<i>Area of Need</i> .....	27
<i>Overload Profiles</i> .....	28
<i>Customer Demographic Profile</i> .....	29
D. PLYMOUTH STREET COOLING PROJECT (UTILITY-SITED ENERGY STORAGE TECHNOLOGY OPPORTUNITY) – BROOKLYN, NY .....	30
<i>Project Timeline</i> .....	30
<i>Project Overview and Requirements</i> .....	31
<i>Performance</i> .....	31
<i>Size of System</i> .....	31
<i>Operation Scenarios</i> .....	31
<i>Maintenance and Operational Life</i> .....	32
<i>Efficiency</i> .....	32
<i>Con Edison System Interconnection</i> .....	32
<i>Optional Steam Connection</i> .....	33
<i>Scalability</i> .....	33
<i>System Grounding</i> .....	34
<i>Auxiliary Power</i> .....	34
<i>Commercial Arrangements</i> .....	34
<i>General</i> .....	34
<i>Project Tenure</i> .....	34
<i>Performance Metrics</i> .....	35
<i>Cost of Installation and Operation</i> .....	35
<i>Construction Considerations</i> .....	35
<i>Permitting</i> .....	35
<i>Operating Environment</i> .....	35
<i>Footprint</i> .....	35
<i>Sound &amp; Electromagnetic Interference Limits</i> .....	37
<i>Emissions and Waste</i> .....	37
<i>Additional NWS Proposal Requirements</i> .....	38



*Proposed Solution Description Section:*..... 38

*Detailed Costs Associated with Proposed Solution Section:*..... 39

*Risks, Challenges and Community Impacts Section:* ..... 39

*Additional Proposal Criteria for Utility-Sited Energy Storage Opportunity* ..... 39

E. RESPONDENT CHECKLIST ..... 40

## Introduction

Consolidated Edison Company of New York, Inc. (the “Company” or “Con Edison”) is extending a request for proposal (“RFP”) for the submission of proposals from qualified and experienced vendors (“Respondents”) with the capability to deliver innovative Distributed Energy Resource (“DER”) solutions that provide subtransmission and distribution system load relief through non-wires solutions (“NWS”). This RFP is requesting responses for four distinct projects. Please specify the project(s) that you will be submitting a response on. Respondents may respond to one or all projects identified. The project opportunities identified in this RFP are the following:

- Water Street Cooling Project
- Williamsburg Feeder Relief Project
- Plymouth Street Cooling Project
  - Customer-sided opportunity
  - Utility-sited energy storage technology opportunity

## Background

Consolidated Edison, Inc., is one of the nation’s largest investor-owned energy companies, providing electric service to approximately 3.3 million customers and gas service to approximately 1.1 million customers. Consolidated Edison, Inc., provides a wide range of energy-related products and services to its customers through its two regulated subsidiaries: Con Edison, which provides electric, gas and steam services to New York City (“NYC”) and Westchester County; and Orange & Rockland Utilities, Inc., which provides electric and gas services in Rockland County and Orange County in New York State, and parts of New Jersey.

## Definitions

**NWS:** A solution proposed in an identified area as an alternative to a traditional infrastructure resolution for a distribution or transmission problem. Con Edison will seek to assemble a portfolio of DER solutions to meet the need in the identified area.

**DER:** Energy efficiency, demand response, distributed generation, or other resources that provide load relief for the identified area of need.

**Respondent:** A person and/or entity, or a representative thereof, replying to this RFP.

**Benefit-Cost Analysis (“BCA”):** A BCA will be applied to potential non-wire solution alternatives. The [BCA Handbook](#) was developed in collaboration with the New York Joint Utilities to provide consistent and transparent statewide methodologies that calculate the benefits and costs of potential projects and investments. Information requested in the RFPs is critical to effectively evaluate solutions.

## RFP Purpose

This RFP solicits responses from qualified Respondents that state an interest in supplying Con Edison with solutions for load relief for the NWS projects described in the [Appendices](#). To assist Respondents,



this RFP provides information on the specific NWS projects and also provides requirements that Respondents must follow to submit a proposal.

The projects described in this RFP have specific need years, some of which identify a multi-year need. Projects received will be used to evaluate and determine the load reduction can be achieved and persist throughout the need years identified.

This RFP is open to all DER approaches that display the potential to provide load relief in the areas identified. Proposed solutions should decrease peak load demand and increase reliability at the lowest reasonable cost possible. Con Edison will attempt to build a portfolio of projects that will diversify project execution risks and maximize benefits to customers.

Con Edison expects that each RFP response should at a minimum outline a Respondent's suggested approach, load relief impact, cost for completing the project, project plan or proposal, and a timeline for implementation as outlined in the [NWS Response Requirements](#) section of this RFP. Responses must also include an hourly impact analysis resulting from the proposed DER solution, as well as a fully completed **Non-Wires Solution Questionnaire (Attachment A)**.

Respondents are expected to be financially and technically capable of developing, constructing and operating proposed projects, such that the anticipated benefits can be realized. Con Edison will make reasonable efforts to evaluate each Respondent's solution in a manner that equitably balances that solution against the solutions proposed by other Respondents. Professionalism and organization of proposal responses will also be taken into consideration during the review process. Respondents are provided the same Non-Wires Solution Program Agreement (the "Agreement") used in previous solutions, which contains terms and conditions Con Edison will likely want to pursue under this new RFP, however this agreement serves to provide Respondents an example of what has been used and other potential modifications and arrangements may be pursued.

Responses will be disqualified in the review process if key solution details are left out of the Non-Wires Solution Questionnaire or RFP Response (*e.g.*, nameplate and hourly load relief, full cost details, load reduction for a proposed technology). If Con Edison enters into a contract with a Respondent, then the Respondent will be subject to additional verification milestones to ensure that the Respondent is on track to provide contracted load relief. With regard to any contract entered into with a Respondent to implement a solution, Con Edison may terminate that contract if Con Edison deems that demand reduction goals are not likely to be achieved.

### **NWS High Level Process**

The process shown below is an example of the high-level steps that occur during the identification of NWS, as well as the evaluation, implementation, and verification of the identified solutions. Please note there are multiple actions that take place between each step to move NWS projects forward to implementation and verification of load relief.

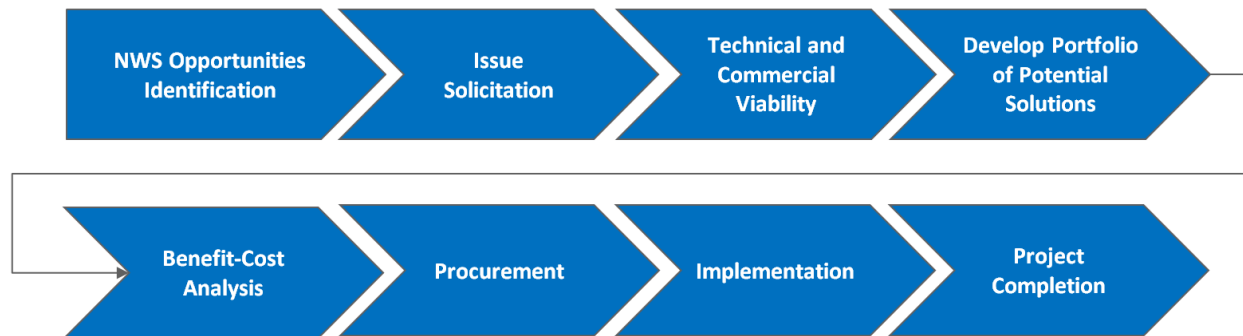

## NWS Project Descriptions

Con Edison has identified projects in specific networks in the Brooklyn service territory for NWS opportunities. Appropriate project descriptions, network maps, load profiles, and customer demographic information can be found in the following RFP sections of the [Appendix](#). The projects are as follows:

- Water Street Cooling Project: Williamsburg & Prospect Park Networks ([Appendix A](#))
- Williamsburg Feeder Relief Project ([Appendix B](#))
- Plymouth Street Cooling Project: Borough Hall Network
  - Customer-sided opportunity ([Appendix C](#))
  - Utility-sited energy storage technology opportunity ([Appendix D](#))

## NWS Response Requirements

This section outlines the requirements for responses to the RFP. The **Non-Wires Solution Questionnaire (Attachment A)** should be fully completed and submitted with the Respondent's proposal. Failure to complete the questionnaire in its entirety may result in disqualification. Any additional information that Respondents would like to provide about the proposed solution can be included as an attachment to the RFP response. However, priority will be given to the information contained within the specified RFP format and questionnaire. Respondents should note that if selected for implementation of a proposed solution, financial assurances will be required to ensure that the DER measures will be installed and operational on or before the contracted in-service date. Failure to meet contracted milestones may result in underperformance damages. Responses (excluding appendices and attachments) should be no longer than 25 pages. The RFP Response must be submitted with the following key sections:

- Proposed Solution Description
- Project Schedule and Customer Acquisition Plan
- Detailed Costs Associated with the Proposed Solution
- Risks, Challenges, and Community Impacts
- Professional Background and Experience with the Proposed Solution

## Proposed Solution Description

Project proposals must demonstrate how the proposed solution will achieve the demand reductions sought and maximize value to Con Edison's customers. Detailed project information must include:

- Executive summary of proposal and general scope of work
- Technology/Solution description (including discussion on technology readiness, flexibility and applicability)
- Type of contract (e.g., shared savings, performance contract, sale, lease-purchase)
- Performance characteristics of the technology
- One-line diagram
- Hourly electric load reduction provided by the solution
- Detailed calculations, data, methodology, and assumptions used to determine the estimated demand reduction and annual kWh savings attributable to each DER measure proposed.
- Community and environmental impacts associated with the solution
- Specification sheets associated with the proposed solution
- Operation and maintenance plan (if applicable)
- A detailed measurement and verification ("M&V") plan for verifying the solutions' load reduction, including provisions for access by the Company and/or its representatives for quality control and quality assurance (independent M&V may be performed at the Company's discretion including, but not be limited to, verification of continued operation and maintenance of the DER measures for the applicable term)

## Project Schedule and Acquisition Plan

Proposed DER measures must be in service, and the pledged demand reduction must be guaranteed to commence, by the date(s) specified in the NWS Project Descriptions located in the [Appendix](#) of this document. This section must contain a detailed plan to implement the solution, including:

- Implementation plan and detailed timeline from contracting, to implementation and completion of the proposed solution
- Existing partnerships with Engineering, Procurement and Construction firms (not applicable for Appendix A-C)
- Respondents proposing to market the installation of DER measures to customers must include the following:
  - Customer acquisition and marketing plan (not applicable for Appendix D)
  - A full and complete assessment of the DER opportunity, including at a minimum, a description of the markets, such as one-to-four family homes, multifamily buildings, small commercial buildings (e.g., retail stores, restaurants), large commercial buildings (e.g., office buildings, industrial) and government or institutional buildings (e.g., hospitals, hotels, schools, colleges), and the applicable DER measures and technologies to be directed at each selected market or customer segment. An illustration of the marketing and sales strategies that will be employed to capture the selected market or customer segment and to deliver the demand reductions included in their proposals



- (preference will be given to Respondents with pre-existing customer agreements to deploy the solution upon confirmation by the Company and marketing and sales plans must be expressly approved by the Company) (not applicable for Appendix D)
- Letters of support from customers who plan to implement the solution at their site in the applicable area of need identified (**Note:** since customer qualifications will need to be verified and confirmed by Con Edison, please provide customer account numbers) – (Not Applicable for appendix D)

## Detailed Costs Associated with Proposed Solution

This section must include:

- A detailed cost breakdown, also requested in the **Non-Wires Solution Questionnaire (Attachment A)** with detailed explanations and validation of funding strategies providing examples which are provable and repeatable
- Identification of other funding streams that may be utilized to mitigate cost impact to the Company's customers (i.e., City, State, Federal and private sector funding opportunities)
- Description of anticipated financing, including transaction structures and pricing formulas

## Risks, Challenges, Community Impacts

This section must include:

- Identify and explain risks, barriers and challenges associated with implementing the solutions such as:
  - Permitting
  - Construction
  - Operations
  - Customer acquisition
  - Contingency plan for inability to achieve load reduction need
- Detailed description of non-energy benefits associated with the proposed solution
- Information on elements of the proposal that affect the environment and community (both positive and negative) including, but not limited to, associated GHG emissions, waste streams and management, job creation potential, and visual or noise impacts.

## Professional Background and Experience with the Proposed Solution

Respondents must provide the following:

- Firm's core business and organizational structure
- Relevant project experience and examples of prior industry specific work that is similar in nature and relevant to the non-wires alternative solution requirements, with particular emphasis on implementation of the solution, such as at other utilities, large municipalities, co-ops, or any other applicable facilities
- References and contact information of customers where the solutions have been implemented (at least three references). For responses to the Appendix D option, if three customers have not

implemented the system, other references for related work should be included for a total of three. References shall include any authorizations necessary for Con Edison to verify Respondent's related previous work

- Project organizational chart and project team resumes **(include in Appendix)**
- Any other relevant information deemed appropriate and noteworthy supporting and validating the proposed solution **(include in Appendix)**
- Financial statements for the past three years, and services offered **(include in Appendix)**

## NWS Questionnaire

Respondents have been provided with a **Non-Wires Solution Questionnaire (Attachment A)**.

Respondents should provide complete responses in each category identified in the Questionnaire and submit with the RFP proposal. All fields in the Questionnaire are critical to allow for a thorough review of a potential NWS, as well as provide information important to the creation of the portfolio of awarded projects. All tabs within the Questionnaire must be fully completed. Failure to submit a fully completed Questionnaire will lead to disqualification.

## Proposal Evaluation Approach

Solutions proposed in response to this RFP will be reviewed in detail by Con Edison. Con Edison will utilize an evaluation framework to develop the optimal portfolio to address the identified need. Some primary review criteria to be applied to qualified submitted proposals are listed below. The review process is intended to be fair and equitable, with the objective being to achieve the greatest overall value while maintaining the reliability of the electric distribution system.

Respondents should note that although Con Edison will be reviewing the Respondents' proposed solution if the submission criteria are met, there is no guarantee that it will be selected.

Respondents should also note that each measure of any proposal submitted, whether part of a single-measure proposal or a multiple-measure proposal, will be evaluated against other like measures for equal comparison; and, thereafter, the Company may evaluate all measures in the aggregate in a manner that considers the overall benefit to the Company based on the criteria set forth in this RFP, and include considerations that could allow for the selection of individual measures across multiple proposals.

Projects will be disqualified if the Respondent does not provide the necessary information requested in this RFP and solution questionnaire.

## Proposal Criteria

Proposals will be evaluated and scored on the basis of the following criteria which are not necessarily listed in order of significance:

Review Approach	Objective
<b>Proposal Content and Presentation</b>	Information requested has been provided and is comprehensive to allow for evaluation.
<b>Project Costs</b>	Total cost of the project, incentive requested, and \$/MW at peak required from Con Ed for the proposed solution.
<b>Benefit-Cost Analysis</b>	The Company is required to utilize a BCA as outlined in the BCA Handbook filed with the New York State Public Service Commission. A BCA will be applied to the portfolio of solutions to determine the feasibility of implementing an NWS.
<b>Execution Risk</b>	The expected ease of project implementation within the timeframe required for the NWS (e.g., permitting, construction risks, and operating risks).
<b>Qualifications</b>	The relevant experience and past success of Respondents in providing proposed solutions to other locations, including as indicated by reference checks and documented results.
<b>Functionality</b>	The extent to which the proposed solution would meet the defined functional requirements and the ability to provide demand reduction during the peak time and area of need.
<b>Timeliness</b>	The ability to meet Con Edison's schedule and project deployment requirements for the particular non-wires opportunity, reflecting that the detailed project schedule from contract execution to implementation and completion of projects is important for determination of feasibility.
<b>Community Impact</b>	The positive or negative impact that the proposed solution may have on the community in the identified area (i.e., noise, pollution).
<b>Customer Acquisition</b>	The extent to which Respondent's proposed solution would fit into the needs of the targeted network(s), the customer segment of the targeted network(s) and the customer acquisition strategy (Preliminary customer commitments from applicable customers will be highly desirable.)- <b>not applicable for Appendix D</b>
<b>Availability and Reliability</b>	The ability of the proposed solution to provide permanent or temporary load relief will be considered, along with the dependability and benefits that would be provided to the grid.

<b>Innovative Solution</b>	Innovative solution that (i) targets customers and uses technologies that are currently not part of Con Edison’s existing programs, (ii) targets generally underserved customer segments, and/or (iii) is based on the use of advanced technology that helps foster new DER markets and provides potential future learnings.
----------------------------	--

## Instructions to Respondent

Respondents are strongly encouraged to submit their proposal in accordance with the summary instructions outlined in this section. The proposal content should focus on the requirements of the [NWS Requirements](#) section above. Additionally, the submittal of a fully completed **Non-Wires Solution Questionnaire (Attachment A)** is required as a separate attachment. There may be such other requirements as may be stated throughout this RFP. Responses (excluding appendices and attachments) should be no longer than 25 pages.

Respondents are required to submit their bid response through the Company’s Procurement System (“Oracle RFQ System”). Any limitation regarding a Respondent’s ability to supply information requested in this RFP (or to support or perform a particular function or service) should be explicitly stated in the proposal response. Any Respondent partnering with other solution providers to perform a particular function or service must be explicitly stated.

## RFP Schedule

Below is the expected schedule to be followed for this solicitation:

RFP Solicitation Milestones	Completion Date*
RFP issued	October 31, 2017
Deadline for Respondents to submit clarification questions	November 14, 2017
Con Edison responses to clarification questions due	December 1, 2017
Deadline for Respondents to become enabled in Con Edison Procurement System	December 29, 2017
Qualified Respondents proposals due	<b>January 12, 2018, 5PM EDT</b>

**\*Con Edison reserves the right to change any of the above dates.**

## Contact Information and Questions

All Respondents should direct questions during the clarification question timeframe via email to Michael Heaton, [heatonm@coned.com](mailto:heatonm@coned.com), of Con Edison’s Supply Chain Department. All questions and answers deemed essential for the viable submission of a bid response will be publicly posted at [www.coned.com/nonwires](http://www.coned.com/nonwires). Respondent names will be kept confidential. Respondents must not reach out to other Con Edison personnel regarding this RFP.



Please review the [RFP Clarification Questions document](#) before submitting questions; the answer to your question may already be provided. This will allow a quicker response to questions.

The Company will have no obligation to evaluate late submissions, nor be responsible in any way for any consequences associated with late submissions.

### Proposal Submittal Instructions

All proposals must be submitted through the Oracle RFQ System on or prior to the due date and time. Respondents who fail to submit by the due date and time will be locked out of the Oracle RFQ System. Therefore, Respondents are encouraged to upload submissions well in advance of the closing time to avoid any potential issues that may occur, including any unfamiliarity with the Oracle RFQ System. Respondents who have never participated in Con Edison RFQ must take the following actions to successfully submit a proposal:

1. Download this NWS RFP, **Non-Wires Solutions Questionnaire (Attachment A)**, and Supplier Enablement Template
2. Become enabled in the Oracle RFQ System by submitting the below items to Michael Heaton at [heatonm@coned.com](mailto:heatonm@coned.com)
  - a. W-9 form (version last updated December 2014)
  - b. Supplier Enablement Template (Select **CE Sourcing** under Oracle responsibility field)
3. Receive Formal RFQ response request (will be same information downloaded from non-wires alternative website)
4. Submit response and **fully completed** Questionnaire to Con Edison Procurement System through the Oracle RFQ System

**Please note**, if you are already enabled in Con Edison’s Oracle RFQ system, please email Michael Heaton indicating your interest in participating. Please only follow steps 3 and 4 after you have emailed Michael.

### Proposal Response Format

The response shall include a proposal and the fully completed **Non-Wires Solution Questionnaire (Attachment A)**.

**Note:** The Oracle RFQ System is only capable of accepting individual documents no larger than 5MB in size. Respondents may find it necessary to split up large documents into smaller files due to this system constraint.

The technical proposal response for this RFP shall be submitted as either a Word or a PDF document, and shall be organized as follows:

Proposal Section	Proposal Section Title
N/A	Cover Letter
N/A	Respondent Checklist
N/A	Table of Contents

1	Executive Summary
2	Proposal <ul style="list-style-type: none"> <li>• Proposed Solution Description</li> <li>• Project Schedule and Customer Acquisition Plan</li> <li>• Detailed Costs Associated with the Proposed Solution</li> <li>• Risks, Challenges, and Community Impacts</li> <li>• Professional Background and Experience with the Proposed Solution</li> </ul>
3	Assumptions and Exceptions
Appendix	<ul style="list-style-type: none"> <li>• Organizational Chart &amp; Resumes</li> <li>• Respondent Qualifications and References</li> <li>• Financial statements for the past three years</li> <li>• Other relevant information</li> </ul>
Separate Document (excel-based)	Non-Wires Solutions Questionnaire (Attachment A)

### Cover Letter

The cover letter shall include the following:

- Respondent legal name and address
- The name, title and telephone number of the individual authorized to negotiate and execute the Agreement
- The signature of a person authorized to contractually bind Respondent’s organization
- A statement that the Respondent has read, understands and agrees to all provisions of the RFP, or, alternately, that indicates exceptions will be taken to the RFP

### Respondent Checklist

Respondent should provide to the Company the properly completed [Respondent Checklist \(Appendix\)](#) as part of the proposal.

### Table of Contents

Include a clear identification of the proposal by section and by page number as identified above.

### Executive Summary

In this section, Respondent should provide an executive overview and summary of the key features of Respondent’s solution.

### Proposal

This section should contain a response to the [NWS Requirements](#) section above. The following information addresses major areas that shall be included in Respondent’s proposal:

- [Proposed Solution Description](#)
- [Project Schedule and Customer Acquisition Plan](#)
- [Detailed Costs Associated with the Proposed Solution](#)
- [Risks, Challenges, and Community Impacts](#)

- [Professional Background and Experience with the Proposed Solution](#)

Proposals may also identify areas not included in the Requirements that may be beneficial for consideration, along with a rationale for why the additional recommendation(s) would better help achieve the required load reduction.

### Assumptions & Exceptions

- Respondents should provide a list of assumptions made in developing the response to this RFP that should be considered when evaluating the response
- Respondents should provide a stand-alone section listing any exceptions to the RFP

### Glossary of Terms

Respondent should provide a glossary of terms that is specific to the Respondent's solution.

### Appendix

Respondents should provide information not specifically requested in the body of the proposal in an appendix or as a separate attachment. Such items include:

- Organizational charts and resumes
- Financial statements for the past three years
- Other relevant information

### Non-Wires Solution Questionnaire

Respondent should attach the responses to the **Non-Wires Solution Questionnaire (Attachment A)**, fully completed, with the RFP submittal.

### RFP Terms and Conditions

It is solely the responsibility of each Respondent to ensure that all pertinent and required information is included in its submission. Con Edison reserves the right to determine at its sole discretion whether a submission is incomplete or non-responsive.

Respondents should state clearly all assumptions made with respect to this RFP. In the absence of an explicit statement to the contrary, each Respondent shall be deemed to have agreed with and understood the requirements of this RFP. While Con Edison has endeavored to provide accurate information, Con Edison makes no warranty or representation of accuracy.

Any exceptions to the terms, conditions, provisions, and requirements herein must be specifically noted and explained by Respondent in Respondent's response to this RFP. Con Edison will assume that any response to this RFP expressly accepts all the RFP terms, conditions, provisions and requirements, except as expressly and specifically stated by a Respondent in its response to this RFP.

Respondents agree to keep confidential all information provided by Con Edison in connection with this RFP.

## Qualifications of Respondents

The Company may make such investigation as the Company deems necessary to determine the qualifications of Respondents and proposed subcontractors to perform the work. A Respondent should promptly furnish any information and data as may be requested by the Company as part of any such investigation. The failure of a Respondent to produce timely information and data requested by the Company may provide a basis for rejection of the proposal.

## Proprietary Information

If a proposal includes any proprietary data or information that a Respondent does not want disclosed to the public, such data or information must be specifically designated as such on each page on which it is found. Con Edison shall be held harmless from any claim arising from the release of proprietary information not clearly identified as such by a Respondent. Because of the need for public accountability, the following information regarding the proposal shall not be considered proprietary, even if such information is designated as such: pricing terms and non-financial information concerning compliance with RFP specifications.

## Cost of Proposal Preparation

The cost of preparing a proposal in response to this RFP, including, but not limited to, the cost associated with site visits and preliminary engineering analysis, will not be reimbursed by Con Edison.

## Right to Reject

This RFP shall not be construed to create an obligation on the part of Con Edison to enter into any contract, or to serve as a basis for any claim whatsoever for reimbursement of costs for efforts expended by Respondent. Con Edison shall not be obligated by any statements or representations, whether oral or written, that may be made by the Company, its employees, principals, or agents.

Con Edison reserves the right to accept any responsive proposal, to reject any and all proposals, and to waive irregularities or formalities if deemed to be in the best interests of the Company. Any such waiver shall not modify any remaining RFP requirements nor excuse any Respondent from full compliance with all other RFP specifications and contract requirements if the Respondent is awarded the contract. Con Edison shall reject the proposal of any Respondent that is determined not to be a responsible bidder, or whose proposal is determined by the Company to be non-responsive.

Con Edison reserves the right to withdraw this RFP at any time and for any reason, and to issue such clarifications, modifications, and/or amendments at any time as it may deem appropriate. Receipt by the Company of a response to this RFP confers no rights upon a Respondent, nor any obligations upon the Company.

## Revision to the RFP

Con Edison reserves the right to make changes to this RFP by issuance of one or more addenda or amendments and to distribute additional clarifying or supporting information relating thereto. Con Edison may ask any or all Respondents to elaborate or clarify specific points or portions of their



submission. Clarification may take the form of written responses to questions or phone calls or in-person meetings for the purpose of discussing the RFP, the responses thereto, or both.

If it becomes necessary to clarify or revise this RFP, such clarification or addendum shall be issued by the Company by letter, email or written addendum to the RFP. Any RFP addendum shall be delivered by hand, certified mail, facsimile, e-mail or delivery by courier service which certifies delivery. Only those respondents that have already received the proposal documentation directly from the Company will be provided the clarification. Any addendum to, and/or clarification or revision of this RFP, shall become part of this RFP and, if appropriate, part of the Agreement that derives from the RFP.

### **Basis of Proposal Award**

Award of proposal shall be made to the most responsive and responsible respondent meeting the specifications, price and other factors considered, as determined by the Company, in its sole discretion. The proposal evaluation criteria are set forth within this RFP.

### **Duration of the Contract**

The duration of the Agreement will be for a term specified in the project description, commencing upon the completion of construction unless otherwise provided herein. In the event that the Company determines not to proceed with the project, the successful respondent will be paid in accordance with the amounts as agreed by the Respondent and the Company.

### **NWS Program Agreement**

RFP awardees are expected to sign the NWS Program Agreement proposed by Con Edison. The current Agreement may be found at [coned.com/nonwires](http://coned.com/nonwires) under Related Information. See below for certain items to note in the Agreement, which do not necessarily reflect all of the items that could be important to a given Respondent.

### **Underperformance**

Respondents should note that failure to deliver load relief committed to as part of any solution may result in liquidated damages to Con Edison as provided for by the contract between Respondent and Con Edison.

### **Security**

Respondents are put on notice that if a Respondent's solution is selected, then Respondent may be required to furnish security to Con Edison that demonstrates, among other things, financial capability to pay liquidated damages in the event that the Respondent fails to satisfy its Load Reduction Guaranty during the period required.

### **Subcontracting and Assignment**

No portion of the work associated with any project resulting from a successful response to this RFP by a Respondent may be delegated, subcontracted, assigned, or otherwise transferred without the prior written approval of the Company in each case.

## Appendix:

### A. Water Street Cooling Project

#### Project Description

The Water Street Substation is located in Brooklyn, New York. Per Con Edison’s analysis, Water Street will need up to approximately 43MW of NWS starting in 2019 to defer load relief projects beyond the year 2027. The substation’s capability is 373 MW. The Water Street substation supplies power to the Williamsburg and Prospect Park networks. The traditional load relief solution would involve installing cooling systems on the transformers at Water Street Substation as well as its supply station, Farragut Substation. The traditional solution can be deferred if the incremental year over year need is achieved and persists through the need period.

The Company anticipates the following overload:

Total MW Need	Overload Period	Peak Hour	Need Period
43	11AM-12 AM	9PM	2019-2027

**Note:** All hours refer to hour ending, which denotes the preceding hourly time period. For example, hour ending 6 PM is the time period from 5:01 PM to 6:00 PM

The substation’s year-over-year overload is expected to be the following:

Project	Total CSS Need (MW)	Year-Over-Year Need								
		2019	2020	2021	2022	2023	2024	2025	2026	2027
Water St	43	4	10	10	5	1	4	3	4	2

**Note:** The load reduction need identified for each year will persist through the full need period so the measure implemented must also persist as well.

#### Area of Need

The maps below outline the networks in blue and denotes the area where implementation of DERs would provide load relief.

Prospect Park Network

# Prospect Park



Williamsburg Network

# Williamsburg



### Overload Profiles

The graph below represents the projected load profile of the Water St. Substation.

**WATER STREET AREA SUBSTATION  
10-YEAR HOURLY LOAD FORECAST vs CAPABILITY**

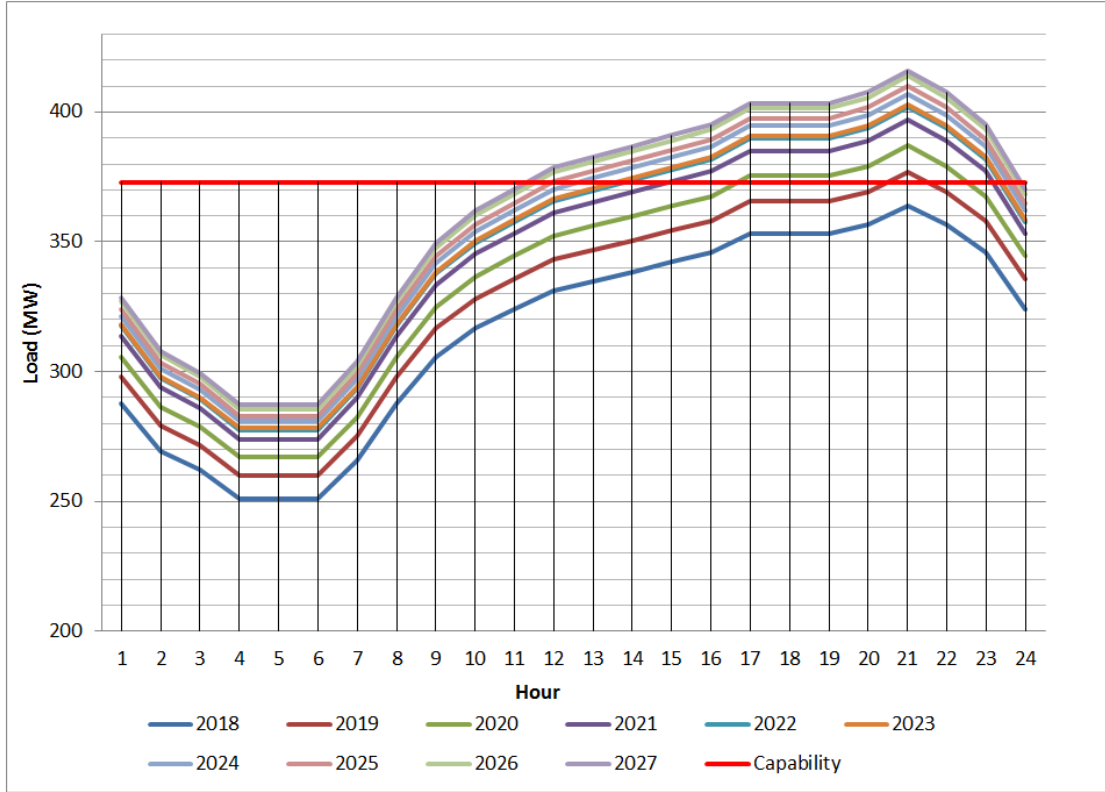

### Customer Profile

The customer profile below describes the customers in the identified area that could provide load relief to the Network.

#### Prospect Park Network

Customer Segmentation	Customer Count	Annualized Consumption [kWh]	High Demand 1 Year [kW]	Max Average Billed Demand [kW]
<b>Commercial &amp; Industrial</b>	<b>130</b>	<b>25,411,441</b>	<b>7,770</b>	<b>458</b>
Education	24			
Hospital	13			
Large Office	2			
Large Retail	5			
NYPA - Com	24			
Warehouse/Industrial	62			
<b>Multifamily</b>	<b>13,961</b>	<b>53,568,893</b>	<b>2,802</b>	<b>102</b>
Large Multi-Family - Common Area	1,342			
Large Multi-Family - Res	12,619			
<b>Residential</b>	<b>13,432</b>	<b>60,356,356</b>	<b>1,276</b>	<b>42</b>
NYPA - Res	1			
Single Family - Res	1,317			
Small Multi-Family - Common Area	1,466			
Small Multi-Family - Res	10,648			
<b>Small Business</b>	<b>1,209</b>	<b>67,140,947</b>	<b>18,027</b>	<b>3,532</b>
Grocery	47			
Miscellaneous/Entertainment	77			
Nursing Home/Lodging	27			
Restaurant	151			
Small Office	673			
Small Retail	234			
<b>Grand Total</b>	<b>28,732</b>	<b>206,477,637</b>	<b>29,875</b>	<b>3,532</b>

## Williamsburg Network

Customer Segmentation	Customer Count	Annualized Consumption [kWh]	High Demand 1 Year [kW]	Max Average Billed Demand [kW]
<b>Commercial &amp; Industrial</b>	<b>1,706</b>	<b>173,973,757</b>	<b>56,773</b>	<b>1,633</b>
Education	152			
Hospital	19			
Large Office	10			
Large Retail	38			
NYPA - Com	216			
Warehouse/Industrial	1,271			
<b>Multifamily</b>	<b>56,628</b>	<b>365,606,891</b>	<b>43,421</b>	<b>737</b>
Large Multi-Family - Common Area	4,542			
Large Multi-Family - Res	52,086			
<b>Residential</b>	<b>37,598</b>	<b>244,982,647</b>	<b>24,060</b>	<b>3,132</b>
NYPA - Res	53			
Single Family - Res	2,820			
Small Multi-Family - Common Area	5,138			
Small Multi-Family - Res	29,587			
<b>Small Business</b>	<b>7,568</b>	<b>269,738,024</b>	<b>96,559</b>	<b>385</b>
Grocery	434			
Miscellaneous/Entertainment	893			
Nursing Home/Lodging	199			
Restaurant	893			
Small Office	3,636			
Small Retail	1,513			
<b>Grand Total</b>	<b>103,500</b>	<b>1,054,301,319</b>	<b>220,813</b>	<b>3,132</b>

## B. Williamsburg Feeder Project

### Project Description

Two feeders in the Williamsburg Network are projected to experience overloads of approximately 3MW, operating at emergency ratings, by the summer of 2020. The traditional alternative for this solution would be to build additional conduit systems to accommodate for the load growth.

Overloads expected to occur at the specific feeders are the following:

Feeder Name	Peak MW need	Overload Period	Peak Hour
6B43	1.2 MW	2PM – 7PM	4PM – 6PM
6B44	1.3 MW	1PM – 10PM	5PM – 6PM

**Note:** All hours refer to hour ending, which denotes the preceding hourly time period. For example, hour ending 6 PM is the time period from 5:01 PM to 6:00 PM.

Targeting specific customers supplied by these feeders will be able to provide load reductions through implementation of DERs. However, each customer may impact the load reduction at varying levels (e.g., Customer A may have a 100 kW impact on the feeder with 1MW of total site load reduction (or generation), while Customer B may have a 300 kW impact to that same feeder with a similar 1MW load reduction). The impact any customer has on a feeder is determined by the impedance of the system from a transformer to the customer, and is therefore a property of the distribution system and is unrelated to the type of customer or the total load.

### Area of Need

The map below outlines the network in light blue and the red and yellow shading identifies the areas where load reduction would provide direct load relief to the overloaded feeders.

This project is focused on direct load relief to overloaded feeders. As such, only qualified customers within the network will provide direct load relief. Qualified Customers have facilities located within the highlighted zone in the network map below. Furthermore, each Qualified Customer will have a distinct contribution (“Distribution Factor”) to the load relief needed. Again, this Distribution Factor is a function of distance (the farther away, the higher the impedance) to the impacted feeder.

For example, a 100 kW NWS implemented at a customer location with a Distribution Factor of 0.3 will result in 30 kW of direct load relief to overloaded feeders. Any load relief achieved for this project will also help with the Water Street project need. The Company will look at proposals throughout the Williamsburg network that provide 1:1 reduction for the Water Street Cooling Project described in Appendix A, and give preference to projects that will also provide relief for the two Williamsburg feeders described in this section.

# Williamsburg

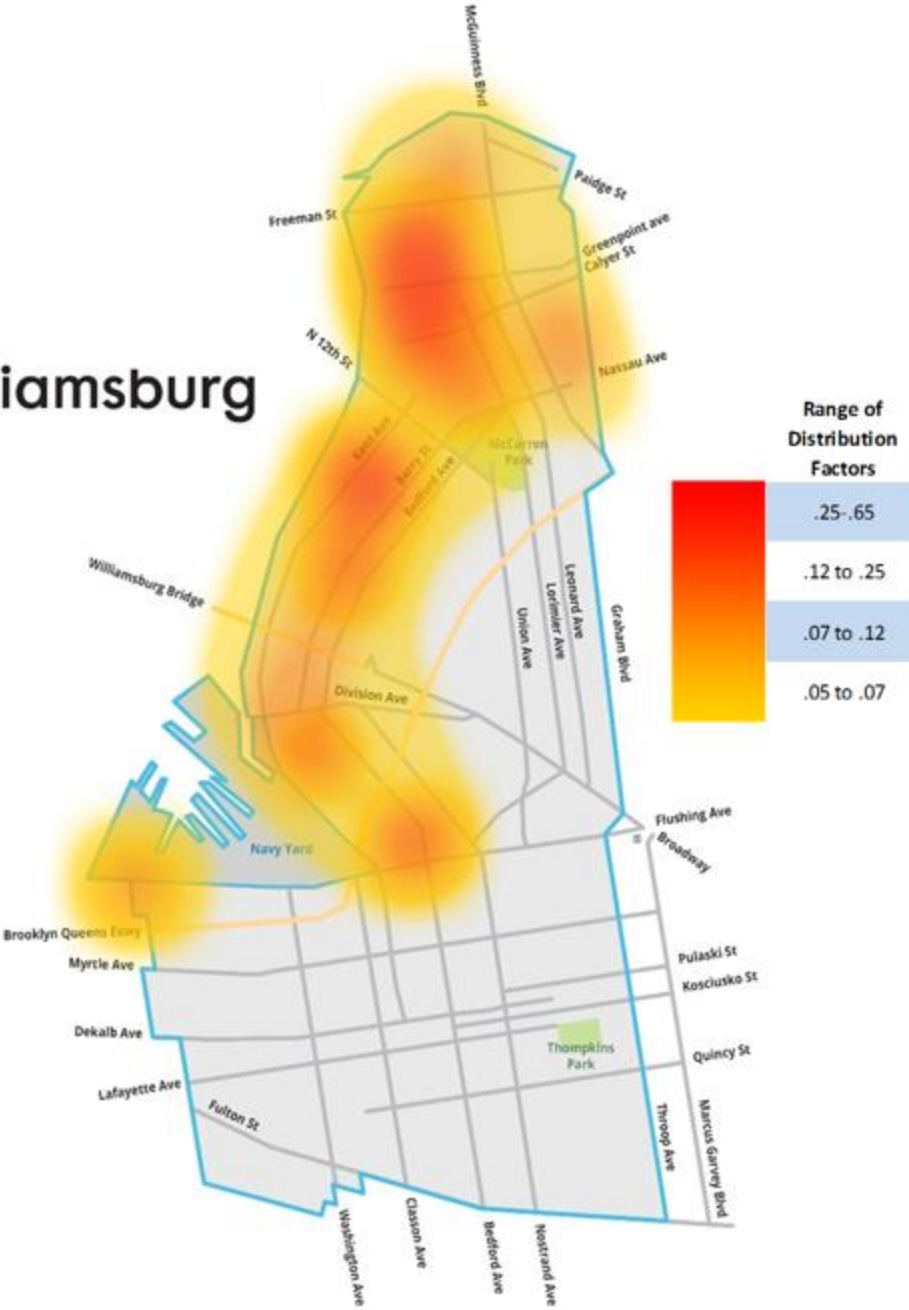



### Overload Profiles

The graphs below represent the overload profile of the feeders identified for potential overload at emergency ratings.

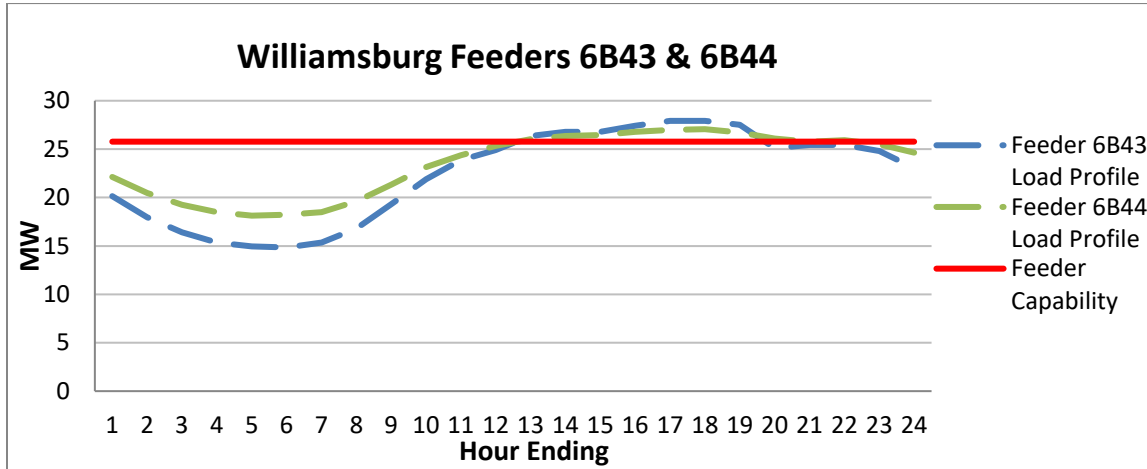

### Customer Demographic Profile

#### Williamsburg Feeder Relief

Customer Segmentation	Customer Count	Annualized Consumption [kWh]	High Demand 1 Year [kW]	Max Average Billed Demand [kW]
<b>Commercial &amp; Industrial</b>	<b>194</b>	<b>14,984,518</b>	<b>5,634</b>	<b>1,393</b>
Education	7			
Hospital	1			
Large Office	1			
Large Retail	8			
NYPA - Com	8			
Warehouse/Industrial	169			
<b>Multifamily</b>	<b>4,249</b>	<b>42,691,372</b>	<b>6,528</b>	<b>534</b>
Large Multi-Family - Common Area	389			
Large Multi-Family - Res	3,860			
<b>Residential</b>	<b>1,994</b>	<b>18,967,867</b>	<b>2,575</b>	<b>645</b>
NYPA - Res	4			
Single Family - Res	159			
Small Multi-Family - Common Area	266			
Small Multi-Family - Res	1,565			
<b>Small Business</b>	<b>589</b>	<b>28,643,490</b>	<b>11,858</b>	<b>385</b>
Grocery	27			
Miscellaneous/Entertainment	84			
Nursing Home/Lodging	9			
Restaurant	63			
Small Office	305			
Small Retail	101			
<b>Grand Total</b>	<b>7,026</b>	<b>105,287,247</b>	<b>26,596</b>	<b>1,393</b>

## C. Plymouth Street Cooling Project (Customer-Sited Solution) – Brooklyn, NY

### Project Description

Plymouth Street Substation supplies power to the Borough Hall network in Brooklyn. Per Con Edison’s analysis, Plymouth Street will need up to 30MW of NWS in this Network starting in 2021 to defer load relief projects beyond the year 2027. The traditional solution would involve installing cooling systems on the transformers at both the Plymouth Street Area Substation and its supply station, Farragut Substation, as well as upgrading the subtransmission feeders associated with these transformers. The first phase of this Plymouth Street project involved replacing the limiting bus sections to provide higher ratings, which, as required, was completed prior to the summer of 2017. The traditional solution can be deferred if the incremental year over year need is achieved and persists through the need period.

Additionally, Con Edison has chosen to allocate 5MW of this project’s load relief need to a utility-sited energy storage technology, with the remainder of the need 25MW satisfied by customer-sited solutions. Details of the components of the utility-sited project can be found in **Appendix D**, along with the requirements that must be provided in addition to the aforementioned in this RFP.

The overload at the substation is expected to be the following:

Total MW need	Overload Period	Peak Hour	Need Period
30	8AM – 10PM	5PM -7PM	2021-2027

**Note:** All hours refer to hour ending, which denotes the preceding hourly time period. For example, hour ending 6 PM is the time period from 5:01 PM to 6:00 PM.

The substation’s year-over-year overload is expected to be the following:

		Year-Over-Year Need						
Project	Total Need (MW)	2021	2022	2023	2024	2025	2026	2027
Plymouth St	30	8	6	0	4	4	5	3

**Note:** Load reduction need identified for each year will persist through the full need period so the measure implemented must also persist as well.

**Area of Need**

The map below outlines the network in blue and denotes the area where implementation of DERs would provide load relief.

**Borough Hall**



### Overload Profiles

The graph below represents the load profile of the Plymouth Street Station.

**PLYMOUTH STREET AREA SUBSTATION  
10-YEAR HOURLY LOAD FORECAST vs CAPABILITY**

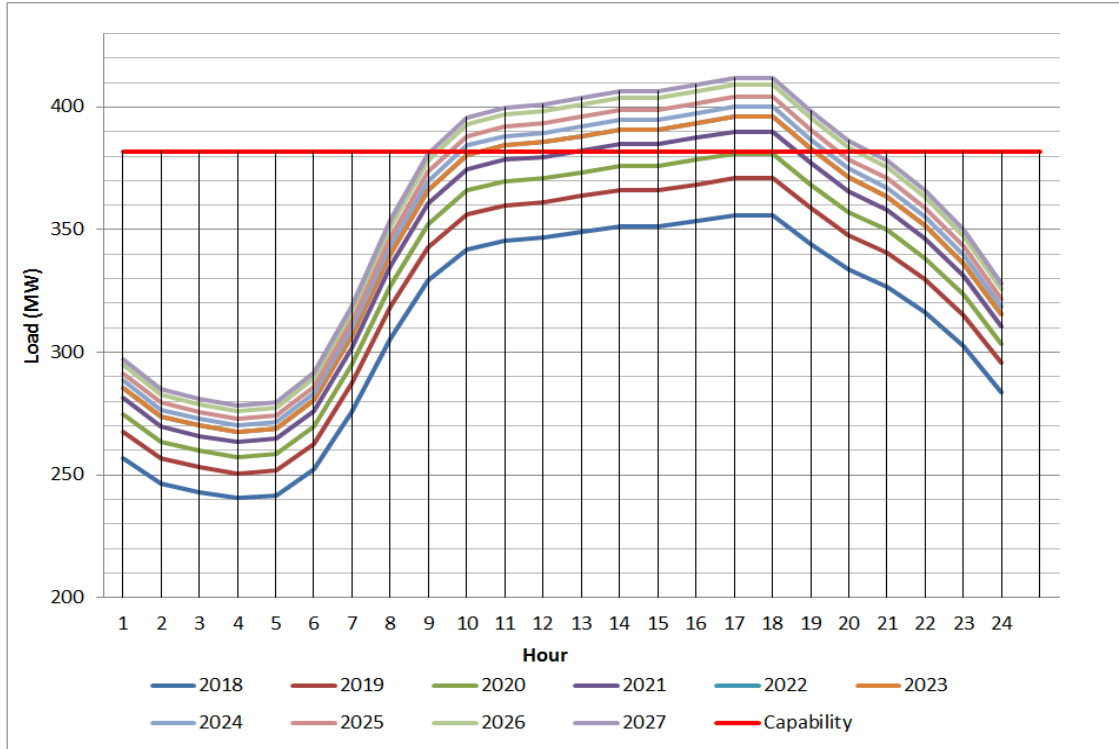



## Customer Demographic Profile

### Borough Hall Network

Customer Segmentation	Customer Count	Annualized Consumption [kWh]	High Demand 1 Year [kW]	Max Average Billed Demand [kW]
<b>Commercial &amp; Industrial</b>	<b>1,247</b>	<b>546,014,282</b>	<b>145,513</b>	<b>4,128</b>
Education	134			
Hospital	13			
Large Office	44			
Large Retail	55			
NYPA - Com	263			
Warehouse/Industrial	738			
<b>Multifamily</b>	<b>29,524</b>	<b>216,071,274</b>	<b>31,059</b>	<b>630</b>
Large Multi-Family - Common Area	2,047			
Large Multi-Family - Res	27,477			
<b>Residential</b>	<b>20,512</b>	<b>140,273,757</b>	<b>14,743</b>	<b>3,045</b>
NYPA - Res	15			
Single Family - Res	1,821			
Small Multi-Family - Common Area	2,694			
Small Multi-Family - Res	15,982			
<b>Small Business</b>	<b>6,153</b>	<b>250,780,761</b>	<b>79,782</b>	<b>646</b>
Grocery	154			
Miscellaneous/Entertainment	396			
Nursing Home/Lodging	128			
Restaurant	575			
Small Office	3,869			
Small Retail	1,031			
<b>Grand Total</b>	<b>57,436</b>	<b>1,153,140,074</b>	<b>271,096</b>	<b>4,128</b>



## D. Plymouth Street Cooling Project (Utility-Sited Energy Storage Technology Opportunity) – Brooklyn, NY

Con Edison is requesting proposals for 5 MW of load relief to be provided by an energy storage technology (or technologies) to the Plymouth St Substation. The Plymouth St need is described in [Appendix C](#) above. Respondents may choose to site their systems at a nearby Con Edison owned property. The systems may be owned and operated by the Respondent or a third party, and Con Edison will provide a reliability payment or other compensation in exchange for reliable load relief during the summer months. Pre-commercial technologies will be considered, however factors such as Execution Risk, Respondent Qualifications and Functionality will be evaluated in the RFP review as stated in the [Proposal Criteria](#) section above.

Eligible technologies must:

- Provide load relief of at least 5 MW for up to 11 consecutive hours during weekdays
- Not locally emit any criteria pollutants or greenhouse gasses
- Have the potential to cost-effectively scale up in power output
- Be able to obtain required NYC permits expeditiously to meet project deadlines

Any response to this utility-sited storage technology section of the RFP will be scored and evaluated separately from the customer-sided solution proposals provided as responses to **Appendices A-C**. If applicable, Respondents are encouraged to submit proposals for projects in both the utility-sited and customer-sided sections of this RFP. If the Respondent chooses to submit proposals for both options, the utility-sited portion of the response must be submitted in a separate document than the customer-sided NWS RFP response.

All proposed systems must conform to all applicable laws, regulations, codes, and orders of governmental entities with jurisdiction.

### **Project Timeline**

The expected project timeline for all utility-sited NWS proposals is shown below. Responses that are selected for implementation must be installed and in service by the end of 2021. The reliability payment will be provided over six years (Jan 2022 – Dec 2027).

Year	Milestone
October 2017	RFP Issued.
Prior to Dec 2019	Contracting and Engineering Design
Jan 2020-Dec 2021	Construction and Installation
Jan 2022- Dec 2027	System in Service

### Project Overview and Requirements

This section provides background information and detailed requirements for the utility-sited energy storage technology responses to this RFP.

- Performance: Proposed technology and how it addresses Con Edison’s system needs
- Commercial Arrangements: Commercial aspects of the project and how the Respondent would be compensated
- Construction Considerations: Construction and installation of the proposed system

### Performance

#### Size of System

The proposed energy storage system must be capable of providing at least 5 MW of power. The Respondent may propose systems of nameplate capacity greater than the requested 5 MW to access wholesale market or other revenues, but systems must adhere to all requirements set forth in this RFP, regardless of size. The Respondent should be aware that its response to the RFP may be evaluated alongside other solutions providing only 5 MW. The Respondent is responsible for all additional costs associated with installing a system larger than 5 MW, such as infrastructure upgrades and interconnection costs.

#### Operation Scenarios

The system must provide load relief during the period hereby referred to as the “summer period” (May 1 through September 30). The storage system must be able to provide relief for up to five consecutive weekdays over four consecutive weeks (for a total of 20 days) during a worst-case scenario over the summer period. If needed, sufficient advance notification will be provided to allow the Respondent to bid into the NYISO Day-Ahead Market.

When called upon, the proposed storage system would be required to discharge for a maximum of 11 consecutive hours. The time windows for charging and discharging during the summer period are shown in the table below. During emergency events, Con Edison reserves the right to request that the storage system cease charging in order to reduce load on the distribution system.

Operation Mode	Time Window
Discharging	10AM – 8PM
Charging	8 PM – 10AM on weekdays. All day on weekends.

Outside of the summer period the storage system may charge and discharge at any time to maximize additional revenue streams. However, the system may not charge during the substation’s peak hours, regardless of the time of the year. The peak hours of the Plymouth Street substation are shown in [Appendix C](#).

**Maintenance and Operational Life**

The Respondent shall be responsible for operation and maintenance of the storage system. The time period and duration for required maintenance and downtime must be specified in a schedule and is only permitted outside of the summer period. In addition, the Respondent shall indicate the expected lifetimes of key system components, including expected cycle lifetime of the storage module and associated subsystems, component calendar lifetimes, and a schedule of anticipated wear and replacement.

**Efficiency**

Efficiency calculations shall be performed on a full charge/discharge cycle basis. Energy consumption associated with auxiliary systems during charging or power delivery shall be incorporated into the calculations. Energy consumed outside of the charge/discharge cycle (e.g., during stand-by mode) should not be included in the efficiency calculation but should be indicated.

**Con Edison System Interconnection**

The system will be interconnected with Con Edison’s electrical system at the Point of Common Coupling (“PCC”) between the storage system and utility as shown in the figure below. The PCC for storage systems is a service bus operating at the rated generator or storage system output voltage (typically 13 kV or 460 V). Charging and discharging currents may not exceed 185 A at 27 kV.

The storage system shall be fed by three redundant extensions from existing 27 kV feeders to maintain an N-2 reliability configuration. As such, each feeder bay at the interconnection shall include a primary service feeder breaker, a transformer, and a secondary circuit breaker according to Company specification EO-2022. A proposed electric connection schematic is shown below.



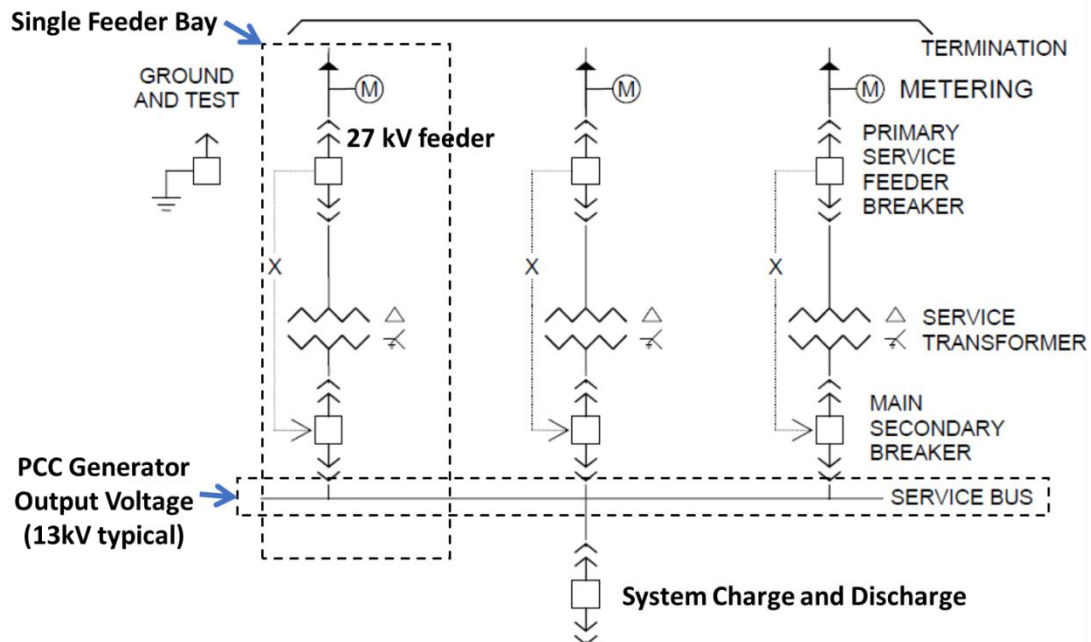

The storage system interconnect must follow the following IEEE standards: IEEE 1547-2003, IEEE Standard for Interconnecting Distributed Resources with Electric Power Systems for protection during discharge mode, and IEEE 519, IEEE Recommended Practices and Requirements for Harmonic Control in Electrical Power Systems for protection during charging mode.

The storage system shall follow the latest revision of [Con Edison specification EO-2115 "Handbook of General Requirements for Electrical Service to Dispersed Generation Customers."](#)

### Optional Steam Connection

A steam pipe runs through the Con Edison property and there is a possibility that the steam may be made available for use in the Respondent's system. The interconnection would be provided by Con Edison with conditions at approximately 400 psi and 445°F. Since access to the steam is not certain, Respondents proposing a design with steam must also include an additional baseline electric only design that does not require steam. The Respondent would be responsible for any costs associated with steam consumption and this should be reflected in the cost breakdown. Although steam cost varies by time of year and annual total volume, for Respondent analyses, the fixed values on page 29 of [Con Edison's 2016 Annual Report](#) should be used for financial analysis. Note that steam condensate has an approximate pH level of 5 and any waste condensate must be discharged at the appropriate conditions described in the [Emissions and Waste section](#).

### Scalability

Although Con Edison is currently seeking 5 MW of load relief from energy storage technologies at this time, the Company sees potential for these technologies to meet additional future needs. Accordingly, proposed technologies should demonstrate the potential to expand cost effectively in output power.

## System Grounding

A suitable equipment grounding system that uses accepted engineering practices and adheres to standards must be implemented for the storage system. The storage system ground will be tied to the existing Plymouth St. substation transformer grounding system.

All exposed non-current carrying metal parts shall be solidly grounded. Particular attention should be given to prevention of corrosion at the connection of dissimilar materials such as aluminum and steel.

The system must adhere to the following standards:

- IEEE 1048-2003: Guide for Protective Grounding of Power Lines
- IEEE 1100-1999: IEEE Recommended Practice for Powering and Grounding Electronic Equipment
- IEEE 1050-1996: Guide for Instrumentation and Control Equipment Grounding in Generating Stations
- IEEE 1143-1994: Guide on Shielding Practice for Low Voltage Cables
- IEEE 081P-1983: Guide for Measuring Earth Resistivity, Ground Impedance and Earth Surface Potentials of a Grounded System
- NEC Article 250 – Grounding
- NESC Section 9
- OSHA 1926 Subpart V – Power Transmission and Distribution

## Auxiliary Power

The auxiliary power system and control system should provide for whatever emergency power is necessary for an orderly system shutdown during abnormal conditions such as a loss of utility power. The auxiliary power system and control system should also provide for the capability to restart the storage system automatically after system shutdown of several days duration.

## Commercial Arrangements

### General

Con Edison will provide reliability payments or other compensation to the Respondent for the system service throughout the operational period. In order to provide the most competitive response, the Respondent is encouraged to use a value-stacking approach for its business plan to access wholesale market revenues or other value streams available. These items must be included in the **NWS Questionnaire (Attachment A)**.

### Project Tenure

The installed storage system will have a limited planned tenure on Con Edison property from 2020 – 2027. After 2027 Con Edison may require the removal of the system or the Company may pursue an arrangement to purchase the system, extend the reliability contract and/or expand the system.

Additionally, should the storage system fail to satisfy the performance metrics during the summer period, Con Edison reserves the right to order the system's removal. Should the installed system require

retirement and removal at any point during its lifetime, the Respondent will be responsible for all associated costs.

### Performance Metrics

In order to receive the full proposed reliability payment, the storage system must perform as described below during the summer period:

- Power: Consistently output a minimum of 5 MW throughout the entire discharge period
- Frequency: The system must consistently output power at 60 Hz when called upon

Unsatisfactory performance will lead to a deduction from the reliability payments.

### Cost of Installation and Operation

Con Edison will lease the land for the installation of the storage system to the Respondent at a nominal price. The respondent will be responsible for all electricity costs for charging, auxiliary and any other power.

The connection to the electric distribution system from the Plymouth Street substation to the installed storage system through feeder extensions and construction manhole vaults will be provided by Con Edison. The construction of feeder breakers, service transformers, and secondary circuit breakers as shown in the diagram in the [Con Edison System Interconnection](#) section above can be conducted by Con Edison for an approximate cost of \$4 million. The costs for both the feeder extensions and interconnection will be included in the benefit-cost analysis of the RFP response. If the Respondent would like to provide a quote for the interconnection at a more competitive cost, this work and the associated cost must be added to the RFP response. The interconnection must adhere to the guidelines set forth in the Con Edison specification EO-2022, which will be provided as an attachment through the Oracle system.

Should the Respondent propose a system larger than 5 MW, any additional costs in the feeder extension or interconnection would be borne by the Respondent.

### Construction Considerations

#### Permitting

The Respondent is responsible for identifying and obtaining all pertinent permits for the installed storage system. Areas for relevant permits include but are not limited to: Civil, Structural, Environmental, and Fire Safety.

#### Operating Environment

The storage system will be installed in an outdoor unsheltered environment near sea level and may be exposed to flooding. The Respondent should consider various flood protection strategies such as elevating the storage system, water pumps, and flood walls.

#### Footprint

The site available for the storage system installation is shown in the figure below:

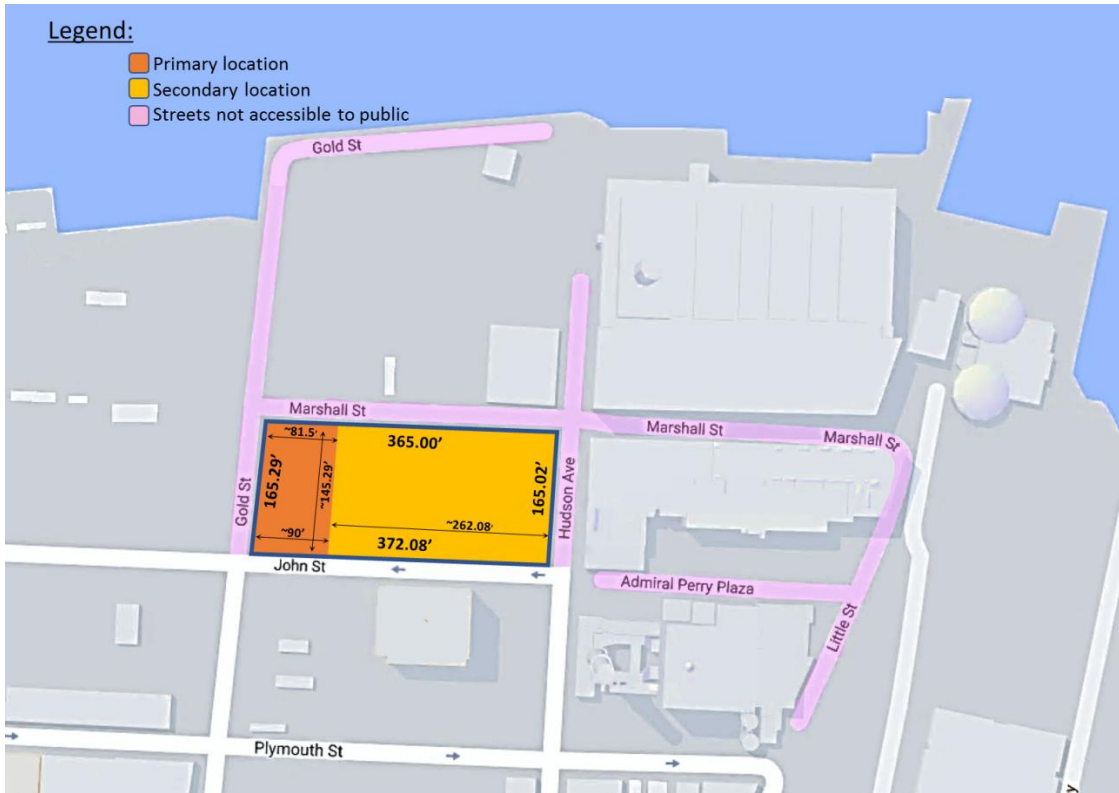

The installation site is split into two sections, and the proposed storage system is allowed to occupy both locations. The Respondent should note that the Secondary location contains buried concrete walls that may serve as an obstruction, while the primary location will be largely unobstructed.

The installation site is surrounded by preexisting walls and the combined system height cannot exceed the height of the walls for the purpose of limiting visibility of the system to the community. However, the backfill present within the extents of the installation site is on a gradient between John Street and Marshall Street so that the maximum allowable height varies between 12 feet and 18 feet, as illustrated in the figure below. Modifications to the backfill dimensions within the primary location are possible, but would require prior Con Edison approval:

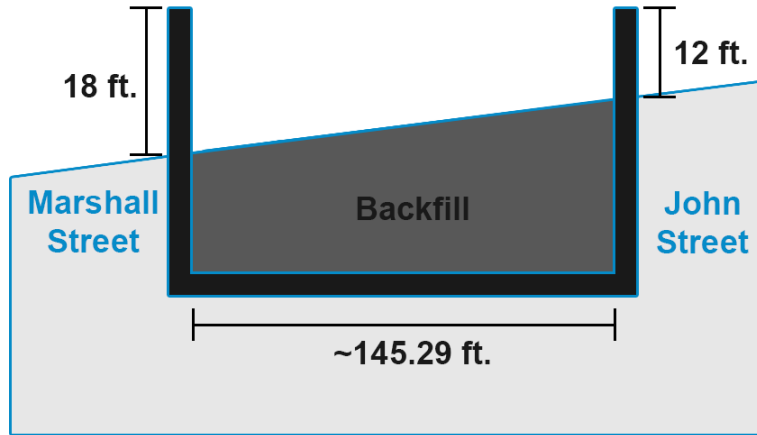

Figure not drawn to scale

All subsystems must be above ground and all interconnection to Con Edison systems will be limited to above ground connections. In addition, the proposed storage system should not require significant site reconstruction or any remediation. The Respondent should seek to minimize digging on Con Edison property.

#### **Sound & Electromagnetic Interference Limits**

The storage system's noise levels should not be audible on a public street. A noise mitigation plan must be developed prior to any construction work.

System operation and all construction work must adhere to the [NYC Noise Code](#).

#### **Emissions and Waste**

The proposed storage systems should not locally emit any pollutants or greenhouse gases through any of its subsystems and any projected wastes must be identified in this proposal.

Waste water or condensate that is discharged from the storage system should be at appropriate conditions and pose no harm to people or the environment. With approval of the NYC Department of Environmental Protection (DEP) and New York State Department of Environmental Conservation (DEC), water can be discharged to the sewer system or the nearby river, provided that water discharge complies with the conditions shown in the table below. The Respondent is responsible for all required treatment equipment and should include details on the equipment in its proposal as part of Respondent's costs. The allowable conditions for discharge are shown in the table below.

	Sewer	River
<b>pH</b>	5 - 12	6 - 9
<b>Total Suspended Solids</b>	350 ppm/day (daily max)	100 ppm/day (daily max), 30 ppm/month (monthly average)
<b>Temperature</b>	< 150°F	< 100°F
<b>Flow Rate</b>	To be determined*	> 75,000 gallons per day
<b>Additional Notes</b>	No discharge during wet weather to prevent combined sewer overflow	May require additional permitting

\*Actual flow rate limit to be determined upon approval from NYC DEP and NYS DEC. Similar sewage systems are restricted by an upper limit of 75,000 gallons/day, shared between all connected facilities.

### Additional NWS Proposal Requirements

In addition to the requirements requested in the [NWS Response Requirements](#) section on Page 6, proposals for the Utility-Sited Energy Storage Technology Opportunity should also address the following in the indicated section:

#### Proposed Solution Description Section:

- Describe ramp up time and quick start capabilities of the system
- Calculation and discussion of the expected efficiencies of the major subsystems, losses from auxiliaries, as well as the overall system efficiency. Losses in standby mode should also be provided
- Description of the scalability potential of the storage system
  - Maximum MW to which the storage system can reasonably scale up to for an 11 hour discharge period after 2027
  - Any accommodations required such as charge/discharge currents exceeding the upper limit provided above, and changes to physical footprint
- Describe any storage system sheltering and flood protection strategies
- Schedule for maintenance and any other system downtime
- Describe expected wear and replacement timelines of storage module and subsystem components
- List all required NYC permits and provide a plan to obtain them expeditiously in order to meet project deadlines

**Detailed Costs Associated with Proposed Solution Section:**

- A proposed annual reliability payment or other compensation model along with a schedule by which payments would be reduced for poor performance
- A business plan for potential operation beyond 2027 including possible extension of the reliability contract, purchase of the system by Con Edison, and expansion of the system.

**Risks, Challenges and Community Impacts Section:**

- The Respondent should provide a full Failure Mode and Effects Analysis (“FMEA”). The FMEA should include
  - All relevant mechanical, electrical and chemical hazards associated with the proposed storage system
  - All failure modes and their respective contingency plans. Failure modes that produce hazardous conditions for personnel and the environment should be further discussed. Other safety concerns not tied to failure modes should also be identified
  - The likelihood of occurrence, the potential level of severity and proper mitigation strategies for all hazards discussed
  - Discussion of sensors, monitors, alarms, and emergency response equipment present in all major subsystems in case of failure
- Discussion of sound levels, electromagnetic interference levels and projected waste discharge

**Additional Proposal Criteria for Utility-Sited Energy Storage Opportunity**

Proposals for the Utility-Sited Energy Storage Technologies Opportunity will not be evaluated on the Customer Acquisition criteria. In lieu of the need to acquire customers for this project, proposals will be evaluated based on the following supplementary criteria in addition to those described in the [Proposal Criteria Section](#).

Review Approach	Objective
<b>Potential Hazards</b>	The demonstration of a full Failure Modes and Effect Analysis (FMEA) outlining all potential hazards, their likelihoods, severities and mitigation strategies.
<b>Scalability</b>	The maximum output power the storage system can reasonably scale up to, the associated costs, as well as the accommodations required and change to physical footprint.



### E. Respondent Checklist

The Respondent must provide the following checklist which must be properly completed with the proposal and submitted to the Company as part of the proposal.

Checklist Item	Initial
RFP RESPONSE SPECIFIED FOR APPLICABLE PROJECT (Please check all that apply) <input type="checkbox"/> Water Street <input type="checkbox"/> Williamsburg Feeder <input type="checkbox"/> Plymouth Street Cooling Project (Customer-sided solution) <input type="checkbox"/> Plymouth Street Cooling Project (Utility-sited solution)	
REVIEWED ALL RFP DOCUMENTS AND LAWS AND REGULATIONS THAT IN ANY MANNER MAY AFFECT COST, PROGRESS, OR PERFORMANCE	
FULLY COMPLETED PROPOSAL ADHERING TO THE FORMAT PROVIDED WITHIN THIS RFP	
ENABLED IN CON EDISON PROCUREMENT SYSTEM	
FULLY COMPLETED NON-WIRES SOLUTION QUESTIONNAIRE (ATTACHMENT A)	
<ul style="list-style-type: none"> <li>• Summary</li> </ul>	
<ul style="list-style-type: none"> <li>• Energy</li> </ul>	
<ul style="list-style-type: none"> <li>• Financials</li> </ul>	
<ul style="list-style-type: none"> <li>• Additional Review Criteria</li> </ul>	

**NOTE:** FAILURE TO COMPLY WITH RFP PROCESS, COMPLETE AND SUBMIT OF ALL THE ABOVE DOCUMENTS ON THE FORMS PROVIDED HEREIN, WILL RESULT IN A REJECTION OF YOUR BID.

By placing my initials in the boxes provided above, I acknowledge having read and that I understand fully all of the requirements, including with regard to each of the documents referenced herein.

RESPONDENT (SIGNATURE): \_\_\_\_\_

RESPONDENT (PRINT NAME): \_\_\_\_\_

DATE: \_\_\_\_\_