

E330 FOCUS[®] AX
E350 FOCUS[®] AX-SD
E331 FOCUS[®] AXe
E351 FOCUS[®] AXe-SD
Plus Reactive Features (RX)
Family of Solid State Meters
Technical Manual
Document No.: 011808-06
Date: 04/15/2014



Landis
|Gyr+
manage energy better

[Go To Table Of Contents](#)

Information in this document is subject to change without notice. No part of this document may be reproduced or transmitted in any form or by any means, electronic or mechanical, for any purpose without the express written permission of Landis+Gyr Inc.

© 1997, 2002, 2003, 2004, 2011 Landis+Gyr Inc
All rights reserved.

For further information, contact:

Landis+Gyr Inc

2800 Duncan Road

Lafayette, IN 47904 USA

Tel. 765-742-1001 or 800-777-2774

Fax 765-742-0936

Web: <http://www.landisgyr.com>

Document History

Title: FOCUS Advanced Function (AX) & Service Disconnect Technical Manual

Revision Level	Date Issued	Description
Original (1.0)	1/18/08	Initial Issue
2.0	8/31/09	Multiple Revisions/Additions related to new features and FCC
3.0	7/12/10	Revisions due to firmware updates. Wording refined. Formatting made consistent.
4.0	8/1/11	Added Reactive Functions, Tamper Detection, clarified event and error codes and added K-Base bottom/top feed instructions.
5.0	6/10/13	Added AXe features and functions supported by firmware 5.62 and greater.
6.0	4/15/14	Various updates including 12 self-reads, load profile pulse Count, voltage sampling and AXe second demand. Added features supported by firmware up to 5.38 and 5.64.

Table of Contents

1 Overview of Hardware	14
1.1 Display	14
1.2 Cover	15
1.3 Switches	15
1.4 Current Blades	16
1.5 Metrology Board	17
2 Features	18
2.1 FOCUS AX Available Forms	18
2.2 FOCUS AX Service Disconnect Available Forms:	18
2.3 Feature Summary	18
2.3.1 AX Demand (TOU Capable) and	18
2.3.2 AXR TOU/Recorder	18
3 Provision for AMI Integration	19
4 Software and Software Upgrades	19
5 Load Profile	19
5.1 Load Profile Memory Capacity	19
5.2 Load Profile Interval Length	19
5.3 Load Profile Status Flag	20
5.4 Load Profile Recording Channels AX and AXe	20
6 Energy Registers: Recordings and Displays	22
6.1 Digital Processing	22
6.2 Energy Accumulation	22
6.2.1 Programming for Detent (Ignore) Mode	22
6.2.2 Programming for Net Mode	22
6.2.3 Programming for Security (Add) Mode	23
6.3 Summary of Program Choices and Results	23
7 Transformer Factor (TF)	23
8 Demand Registers	23
8.1 Demand Overflow	23
8.2 Demand Intervals	23
8.3 Maximum kW Demand	24
8.4 Five Highest kW Demands	24
8.5 Demand Reset	24
8.6 Power on Demand Delay Timing	24
9 Clock and Calendar Functions	25
9.1 Software Clock	25
9.2 Clock Setting	25
9.3 Date and Time Formats	25
9.4 Calendar	25
9.5 Daylight Savings Time	25
9.6 Time on Battery Carryover	26
10 Power-fail Recovery	26
11 TOU Power Outage Indication	26
12 Demand/TOU upgrade to TOU/LP	26

[Go To Table Of Contents](#)

12.1	TOU Without Battery.....	27
12.2	“Stand-By” mode.....	27
12.2.1	Stand-by in Firmware 5.31 to 5.33.....	27
12.2.2	Stand-by in Firmware 5.34 and later.....	27
12.2.3	Load Profile Interval Length in Stand-by.....	28
13	TOU.....	28
13.1	TOU Rate Schedules.....	28
13.2	TOU Switch points.....	29
13.3	TOU Dates.....	29
13.4	Demand in TOU.....	29
14	Cold Starts.....	30
14.1	Method 1, Optical Cold Start.....	30
14.2	Method 2, Manual Cold Start.....	30
14.3	Register Displays following a Cold Start.....	30
15	Master Reset.....	31
16	Programmable Output Switches.....	31
17	Self-Reads.....	31
17.1	Number of Self-Reads.....	32
17.2	Activation of Self-Read.....	32
18	Security.....	33
18.1	L5 Unlock Switch Sequence.....	33
19	Voltage Quality Information.....	34
19.1	Voltage/Max/Min./Avg.....	34
19.2	Load Profile Voltage Sag Information.....	35
19.2.1	Voltage Sag Alert.....	35
19.3	Load Profile Voltage Swell Information.....	35
19.3.1	Voltage Swell Alert.....	35
19.4	Volt/Amp-hour.....	35
20	Display Operation and GyrBox.....	35
20.1	Diagnostic Display modes.....	36
20.2	Scroll Modes.....	37
20.2.1	Auto Scroll Mode.....	37
20.2.2	Scrolling in the Alternate Display Sequence.....	37
20.2.3	GyrBox.....	37
20.2.4	Manual Scroll Mode.....	37
20.3	Digital Power Indicator.....	37
20.4	Rates.....	37
20.5	Instantaneous Values.....	38
20.6	Power-Up/Cold Start Displays.....	38
20.7	Display of Nominal Service Voltage.....	38
20.8	Potential Indicators.....	38
21	Test Mode.....	38
21.1	Test Mode Display.....	39
21.2	Actions upon Entering Test Mode.....	39
21.3	Action upon Exiting Test Mode.....	39
21.4	Test Mode Demand Functions.....	39

[Go To Table Of Contents](#)

21.5	Miscellaneous Functions During Test Mode.....	39
21.6	Test Mode Time-out.....	39
22	Self-Checking and Error Detection.....	39
22.1	Error Codes.....	39
22.2	Error Conditions.....	41
22.3	Disabling Individual Error Codes.....	41
22.4	Demand Overload Operation.....	41
22.5	Phase Voltage Errors.....	42
23	GyrBox Diagnostics.....	42
23.1	GyrBox Support Software Packages.....	42
23.2	GyrBox Activation.....	42
23.3	Digital Power Indicator (DPI) during GyrBox Activation.....	42
23.4	Display Format and Reference.....	42
23.5	GyrBox Display List.....	43
23.6	Diagnostic Checks.....	43
23.6.1	Diagnostic D1 (Polarity, Phase, & Energy Flow Check).....	44
23.6.2	Diagnostic D2 (Phase Voltage Deviation Check).....	44
23.6.3	Diagnostic D3 (Inactive Phase Current Check).....	44
23.6.4	Diagnostic D4 (Phase Angle Displacement Check).....	44
23.6.5	Diagnostic D5 (Future).....	45
23.6.6	Diagnostic D6 (Current Magnitude Imbalance Check).....	45
23.6.7	Diagnostic D7 (Energy Polarity Check).....	45
23.7	Diagnostic Counters.....	45
23.8	Diagnostic Error No-Check Conditions.....	45
23.9	Diagnostic Check Output Contact.....	45
23.10	Tamper Detection.....	45
23.11	Excessive Leading Current (Magnetic/DC Detection).....	46
24	Optical Port.....	47
24.1	ANSI Type II Optical Communications Port.....	47
24.2	Optical Port Lockout.....	47
25	FOCUS AX Service Disconnect.....	47
25.1	Applications.....	47
25.1.1	Manual Reconnect.....	47
25.1.2	Service Disconnect Toggle Switch.....	48
25.1.3	Switch Detection (SD Switch Operation Error).....	48
25.2	Remote Operation.....	48
25.3	Service Limiter (programmable time period).....	49
25.4	Soft Fuse (programmable kW level).....	49
25.5	Limiting Repeated Triggers.....	49
25.6	Communications.....	49
26	Error/Event Logs.....	50
26.1	Standard Error Configuration (LCD Displayable if selected, S##) ...	50
26.2	Manufacturing Error Configuration (LCD Displayable if selected, M##).	50
26.3	FOCUS AX and AXe Special Indicators (Meter Displays).....	51
26.4	Optional Event Definitions (Displayed in Meter Event Log if selected)	51
27	Reactive Functions.....	54

[Go To Table Of Contents](#)

27.1	FOCUS RX Available Forms	54
27.2	FOCUS RX Service Disconnect Available Forms:	54
27.3	Software Upgrades to Reactive	54
27.4	Additional Reactive Support.....	56
No independent quadrant reactive data will be available.		56
27.5	Programming for Detent (ignore), Add, or NET with Reactive Metrics ..	56
27.6	Three Highest kW Demands-Reactive	57
27.7	Active and Reactive energy calculations	57
28 AXe Features.....		57
28.1	FOCUS AXe Available Forms	57
28.2	FOCUS AXe Service Disconnect Available Forms:	57
28.3	Load Profile Recording Channels AXe.....	58
28.5	Secondary Demand Recording	58
28.6	Tilt Tamper Detection	58
28.7	AXe LCD Displays.....	59
Appendix B: K-Base Meter Top/Bottom Feed		61
Appendix C: Technical Specifications		62
Appendix D: Normal Phase Angles		66
Appendix E: Service Types		71
Appendix F: Meter Form Schematic Diagrams.....		74

1132 Programming and Communication Customer Notes:

Safety Warnings

The following safety precautions must be observed during all phases of operation, service, and repair of this device. Failure to comply with these precautions or with specific warnings elsewhere in this manual violates safety standards of design, manufacture, and the intended use of the metering instrument. Landis+Gyr Inc assumes no liability for the customer's failure to comply with these requirements.

• **Warning:** Any work on, or near, energized meters, meter sockets, or other metering equipment can present a danger of electrical shock. All work on this product should be performed only by qualified electricians and metering specialists in accordance with local utility safety practices, utility requirements and procedures outlined in Chapter 14 of The Handbook for Electricity Metering (10th edition). The information contained within this manual is intended to be an aid to qualified metering personnel. It is not intended to replace the extensive training necessary to handle metering equipment in a safe manner.

- Use care when servicing with the power on.
- Be aware that dangerous voltages exist at several points within the meter when this product is installed on a meter base.
- Disconnect power before meter disassembly, soldering, or replacing components.

The FOCUS AX meter is connected directly to line potential. Due to the possibility of the potential lines being reversed, points accessible with the cover off may be at line voltage.

LINE POTENTIAL IS PRESENT ON THE INCOMING CONNECTORS ON THE MEASUREMENT BOARD INCLUDING THE BATTERY CONNECTOR.

The connectors have full length insulators crimped onto each connector and are shielded by the housing, but pulling the connector loose will expose the open end and line potential. The option board is connected directly to the main board and may also be at a high potential. The above warning label is affixed to the meter frame and identifies hazards in the meter.

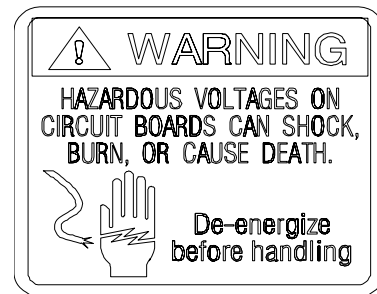

Any option or I/O cables connecting to the meter from the mounting device must use sufficient insulation for the service voltage employed. As a general rule insulation should be designed for a 480 volt AC_{rms} service voltage since service voltage is not always known at the time of meter manufacture.

Warning

All applicable electrical codes and standards must be followed. Failure to use sufficient insulation on option or I/O cables connecting to the meter through the mounting device could cause serious personal injury, property damage, and/or death.

[Go To Table Of Contents](#)

FCC Information:

This device complies with part 15 of the FCC rules. Operation is subject to the following three conditions:

- (1) This device may not cause harmful interference, and
- (2) This device must accept any interference received, including interference that may cause undesired operation.
- (3) For RF exposure, service personnel are to maintain a minimum of 20cm from the RF communications transmitter once installed.

Changes or modifications not expressly approved by Landis+Gyr could void the user's authority to operate the equipment.

Do not change the original antenna without pre-approval from the original meter manufacturer. This will violate the FCC regulations of using the radio.

Note:

Some FOCUS meters may contain AMI modules with RF communications. This equipment has been tested and found to comply with the limits for a class B digital device, pursuant to part 15 of the FCC Rules. These limits are designed to provide reasonable protection against harmful interference in a residential installation. This equipment uses and can radiate radio frequency energy and, if not installed and used in accordance with the instructions, may cause harmful interference to radio communications. However, there is no guarantee that interference will not occur in a particular installation. If this equipment does cause harmful interference to radio or television reception, which can be determined by turning the equipment off and on, the user is encouraged to try to correct the interference by one or more of the following measures:

- Reorient or relocate the receiving antenna.
- Increase the separation between the equipment and receiver.
- Connect the equipment into an outlet on a circuit different from that to which the receiver is connected.
- Consult Landis+Gyr or an authorized technician for help.

Following are FCC identification and Industry Canada numbers for radio systems currently used on FOCUS AX and Service Disconnect:

Silver Spring Networks:

NIC 314 and NIC 311

FCC ID: OWS-NIC514 and OWS-NIC511 IC#: 5975A-NIC514 and 5975A-NIC511

NIC 414 and NIC 411

FCC ID: OWS-NIC714 and OWS-NIC711 IC#: 5975A-NIC714 and 5975A-NIC711

Landis+Gyr EMS :

40-1335 – Gridstream FOCUS AX W/ZigBee

FCC ID: TEB-HUNTSU746 IC#: 5931A-HUNTSU746

40-6203 – Gridstream FOCUS AX Integrated

FCC ID: R7PEG1R1S1 IC#: 5294A-EG1R1S1

26-1240, 1241 – TS2 FOCUS AX W/ZigBee

FCC ID: TEB-HUNTTS764 IC#: 5931A-HUNTTS764

26-1552,1253, 1254, 1255 – AXi FOCUS AX 120V W/ZigBee

FCC ID: TEB-HUNTSU864 IC#: 5931A-HUNTSU864

Aclara PLS:

EMTR-3-FX

FCC ID: PN3Y72698-1 IC#: 7100A-Y726981

EMTR-3

FCC ID: PN3Y72553-1 IC#: 7100A-Y725531

Sensus:

FCC ID: SDBFLEXLG100 IC#: 2220A-FLEXLG100

FCC ID: SDBLGZ1000 IC#: 2220A-LGZ1000

Trilliant Networks:

RES-3000-FOCUSAX-P, RES-3000-FOCUSAX

FCC ID: TMB-EM0069 IC#: 6028A-EM0069

RES-3000-Focus-P

FCC ID: TMB-G30Focus IC#: 6028A-G30Focus

Itron:

Openway

FCC ID: SK9M2LG1 IC#: 864G-M2LG1

Measurement Canada approval:

FOCUS AX-SD and AX: AE-1641

FOCUS AX Polyphase: AE-1723

FOCUS AXe: AE-1967

Introduction to the FOCUS AX, AXe and the FOCUS AX, AXe & Service Disconnect

FOCUS AX is used throughout this manual to refer to the FOCUS AX, AXe, RX, RXe and the Service Disconnect meter unless otherwise stated. Features solely related to the AXe series meter are found in section 28 of this manual.

Following are variations of the FOCUS AX meter family, with and without Service Disconnect:

Focus AX Active Energy with Demand Register (TOU Capable)
Focus AXR Active Energy with Time Of Use Register & 77K Load Profile w/NO BATTERY (This feature requires a two-way AMI system capable of keeping time)
Focus AXR Active Energy with Time Of Use Register & 77K Load Profile WITH BATTERY
Focus RX Reactive Energy with Demand Register (TOU Capable)
Focus RXR Reactive Energy with Time Of Use Register & 77K Load Profile w/NO BATTERY (This feature requires a two-way AMI system capable of keeping time)
Focus RXR Reactive Energy with Time Of Use Register & 77K Load Profile WITH BATTERY
Focus AXe Active Energy with Demand Register (TOU Capable)
Focus AXRe Active Energy with Time Of Use Register & 77K Load Profile w/NO BATTERY (This feature requires a two-way AMI system capable of keeping time)
Focus AXRe Active Energy with Time Of Use Register & 77K Load Profile WITH BATTERY
Focus RXe Reactive Energy with Demand Register (TOU Capable)
Focus RXRe Reactive Energy with Time Of Use Register & 77K Load Profile w/NO BATTERY (This feature requires a two-way AMI system capable of keeping time)
Focus RXRe Reactive Energy with Time Of Use Register & 77K Load Profile WITH BATTERY

The FOCUS AX and the FOCUS AX & Service Disconnect provide the utility industry with reliable, economical, quality solid-state meter and AMI platforms. The FOCUS AX combines the field-proven and time-tested technology of Landis+Gyr's previous solid-state meters. Key functions of the FOCUS AX meter are:

- Allows for modular AMI communications or KYZ option output board (AX only)
- Highly accurate load performance
- Extremely flexible in regards to meter reconfiguration
- Digital Multiplication Measurement Technique
- Non-volatile memory
- 20+ year life expectancy
- Meets or exceeds ANSI standards
- 6 digit LCD and 3 Alphanumeric ID
- Optional remote/optical service disconnect with 200A relay designed for over 10,000 open/close cycles



[Go To Table Of Contents](#)

The FOCUS AX provides more than just reliability and accurate billing data. The FOCUS AX is designed to be a building block for a complete metering system. Combining the FOCUS AX with the 1132 software package yields a complete system for real-time voltage, current, and load data monitoring; user-defined event alerts; graphical load analysis capability; and voltage vector diagrams.

1 Overview of Hardware

1.1 Display

The LCD display has a high contrast that allows visibility from a 6-foot range and from a 150-degree right-to-left angle. The LCD accommodates a 6-digit format, including decimal points between digits as shown below, along with a three-digit alphanumeric indicator, available through programming.

The following display enunciators are available:

- Meter-module/optical communications indicator
- DPI (Digital Power Indicator)
- Alternate ("ALT" in three-digit alphanumeric indicator)
- Test mode indicator
- Current TOU rate indicator
- EOI indicator (End-of-Interval)
- Service voltage (120V 240V or 277V)

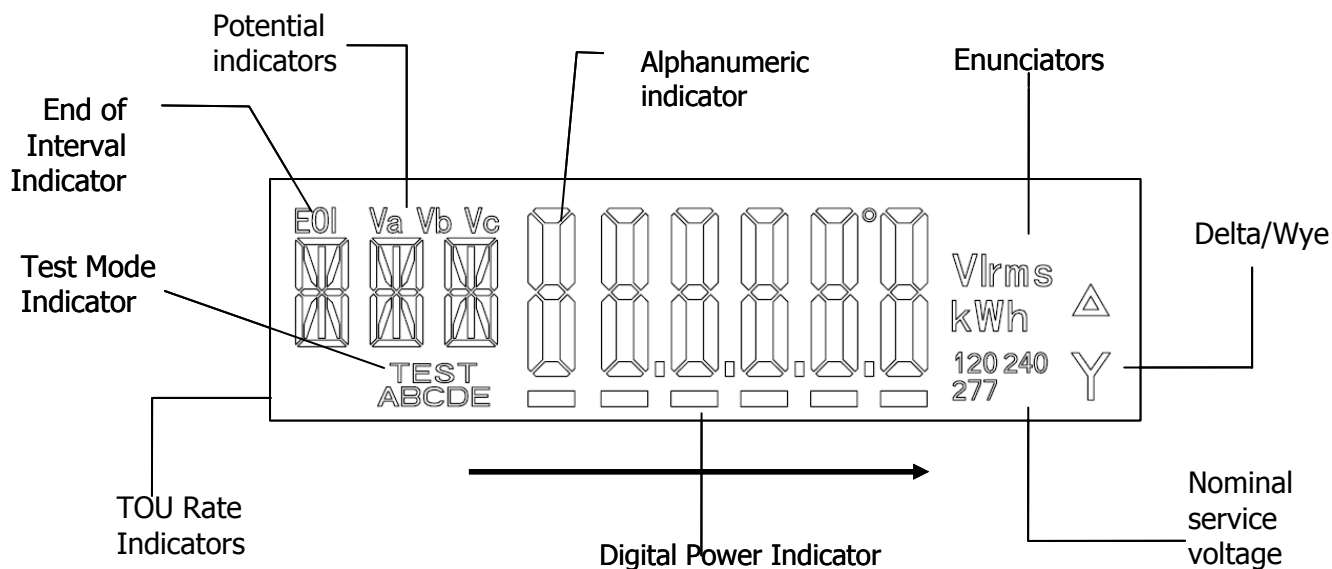

AX LCD Display

See Section 28.7 for FOCUS AXe Display

1.2 Cover

The cover is made of polycarbonate and allows for a clear view of the LCD along with an ANSI C12.18 type optical port. The optical port doubles as an LED for calibration output pulses. The demand reset switch and local reconnect switch are additional options for the cover. The cover must be removed and the meter seal broken in order to cold-start the meter manually. See cover example in section 1.3.

1.3 Switches

The meter has four switches: one for demand reset, one for test mode, one for scrolling displays, and the fourth is the re-connect switch only available on the Service Disconnect (SD) version. The demand reset switch and the SD reconnect switch are accessible through the cover on selected covers. Standard cover, switch and port options are shown in the table below:

Cover Type and Switch Options
Standard Poly with Optical Port & Demand Reset & Reconnect Button
Standard Poly with Optical Port & Demand Reset
Standard Poly with Optical Port Only
Standard Poly with Optical Port & Reconnect Button
Low Profile Poly (5.5 in) w/Configuration Port Only
Low Profile Poly (5.5 in) w/Configuration Port and Reconnect Button
Low Profile Poly (5.5 in) w/Reconnect Button
Low Profile Poly (5.5 in) w/Configuration Port Only

A reed switch is available inside the meter housing at the 12 o'clock position and is used for scrolling the display and activating diagnostic displays.

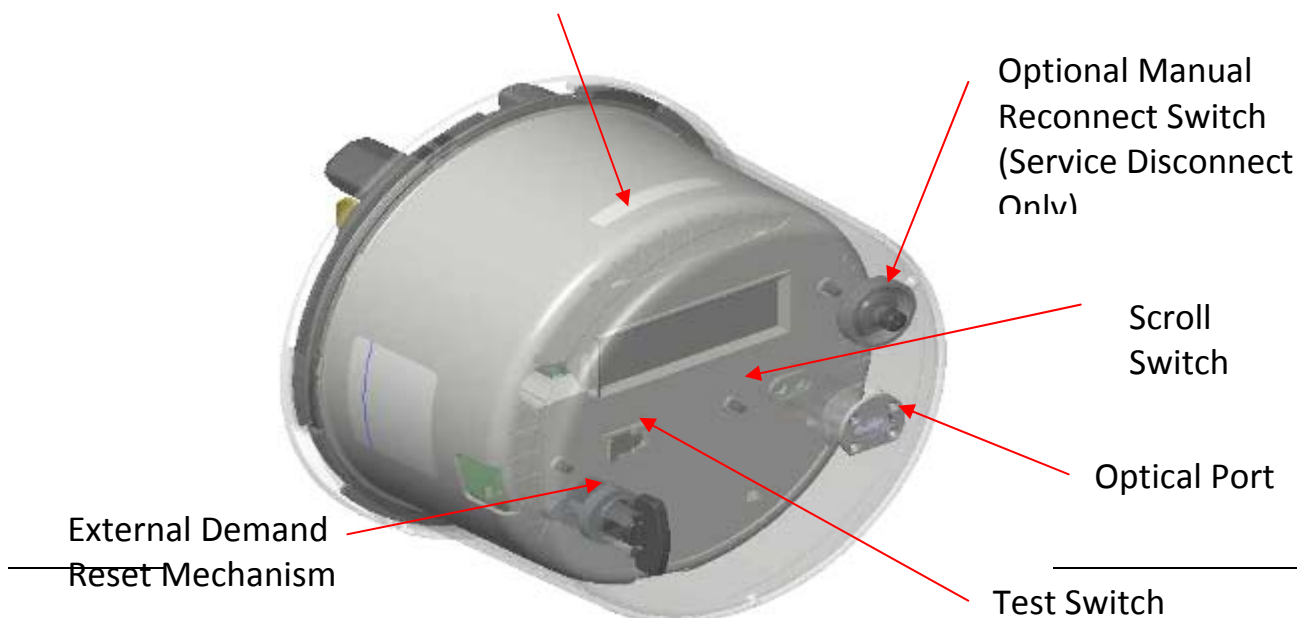

1.4 Current Blades

The FOCUS AX current blades are constructed in a one-piece design. They are made from solid copper and electroplated with tin to prevent corrosion. The current blades on the FOCUS AX Service Disconnect meter consist of one-piece of copper with 5/8" fixed contacts on the load side and three flexible contacts on the line side.



FOCUS AX, AX-SD line side, and AX-SD Load Side blades (2S)

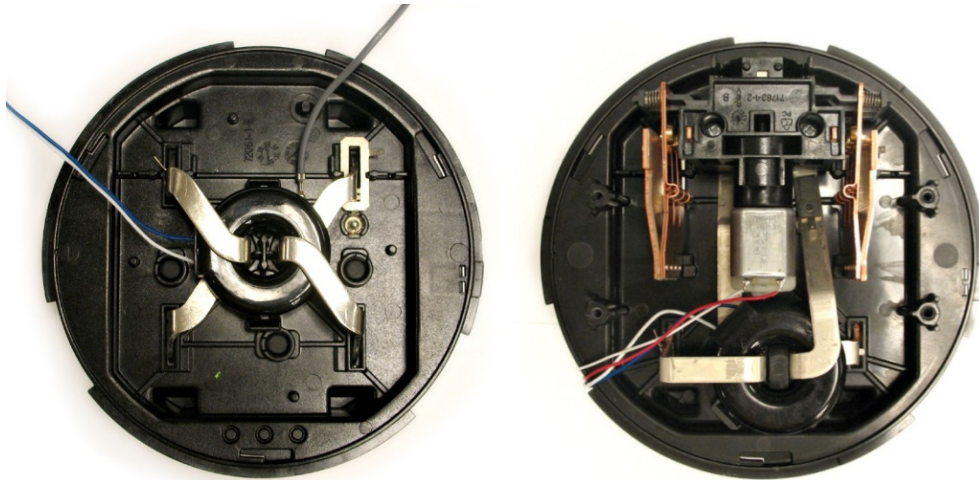

Form 2S bases, Standard and with Service Disconnect Switch

1.5 Metrology Board

View - Facing Base

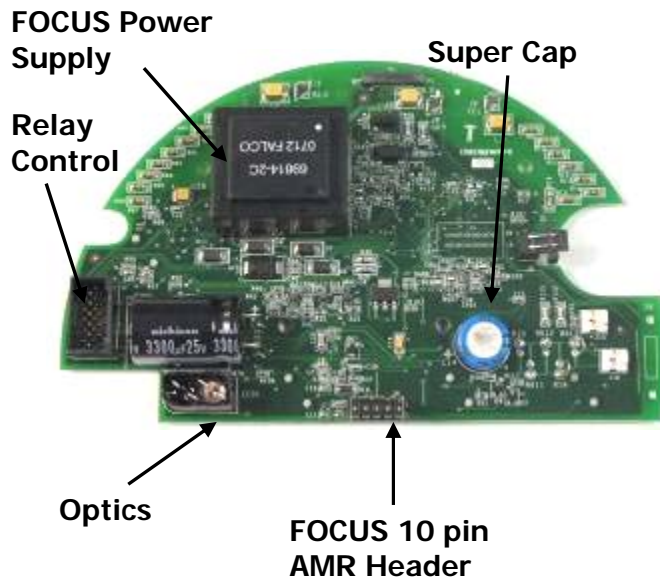

View - Facing Front

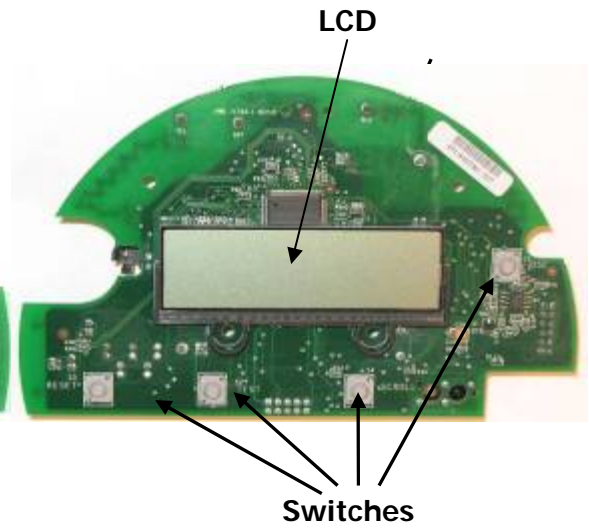

Meter board inside housing

[Go To Table Of Contents](#)

2 Features

2.1 FOCUS AX Available Forms

- Transformer rated: 3S, 4S
 - Self-contained: 1S, 2S, 12S, 25S,
 - Extended Range (class 320): 2SE
 - K-base (class 480): 2K
 - Wide Range Power Supply, 120 – 277 VAC: 9S/8S, 12S, 12SE, 16S (14, 15, & 17S), 16SE (14, 15, 17SE), 36S* (6S), 45S (5S)
-

*Accuracy Class 0.5%

2.2 FOCUS AX Service Disconnect Available Forms:

- Self-contained: 1S, 2S, 12S and 25S

2.3 Feature Summary

2.3.1 AX Demand (TOU Capable) and

The following items are all standard features of the AX and AX Service Disconnect Meter:

- Peak demand
- kWh, and kW demand (TOU capable)
- Bi-directional measurement
- Remote disconnect and reconnect capabilities on the FOCUS AX Service Disconnect
- Display and registers powered with disconnect switch in the open position
- Detects, logs and, reports program or memory failure
- Software and firmware upgrades accepted locally via optical port
- Normal operation during upgrades (display blanks momentarily during F/W Flash)
- Meter software remotely and locally readable
- Default switch position is programmable
- Remote or local load side voltage test
- Self-reads occur at midnight for each register
- Accuracy Class 0.2%

2.3.2 AXR TOU/Recorder

- 8-channels of load profile
- Interval data of 1, 5, 15, 30 and 60 minutes
- Interval data collection for energy consumption
- Meter distinguishes between missing interval and zero consumption
- Meter distinguishes between power outage and zero consumption
- 5-minute interval data is available for a maximum of 45 days for two channels

[Go To Table Of Contents](#)

- Over-the-air-flashable firmware (with select AMI modules)

3 Provision for AMI Integration

- FOCUS AX and Service Disconnect meters feature 0.110 inch voltage fast-on connectors for connecting AMI modules requiring service voltage.
- FOCUS AX and AX-SD feature the same 10-pin header for easy AMI installation.
- Access to Meter Data: All meter data has the capability to be transmitted over the optical port or 10-pin AMI communication header.
- The FOCUS AX is programmable using the 1132Prog/Com software package available from Landis+Gyr.

4 Software and Software Upgrades

The FOCUS AX meter offers flexible upgrade and downgrade firmware to support today's rapidly changing utility environment. The meter programming utilities are 1132Comm for reading and programming and 1132Prog for developing programs. Windows XP (32 bit, SP3) is the only officially supported operating system for 1132Com/1132Prog. Windows 7 (32 bit and 64 bit) is also supported. Consult factory for details.

5 Load Profile

Load profiles record information about energy usage through time. A load profile can provide the consumer and the utility a great deal of information about how energy is being used and how to help conserve it. On the FOCUS AX and AXe, a load profile can contain information of up to eight (8) metrics (channels) in 1 to 60 minute intervals.

5.1 Load Profile Memory Capacity

The maximum number of channels of load profile memory available on FOCUS AX and AXe is eight (8). The load profile memory size is up to 77KB. The reader/programmer is able to initialize load profile memory or disable load profile recording completely. Intervals with no data are registered with a zero fill and include common and channel status.

5.2 Load Profile Interval Length

Load Profile interval lengths include, 1, 5, 15, 30 and 60 minutes. The table below shows the number of days of load profile for the configured interval length and number of load profile channels. Maximum load profile interval length is independent from the demand interval length chosen.

Number of days in load profile (with 77KB):

Channels	Interval Length (in minutes)				
	1	5	15	30	60
1	17.93	89.67	269.00	538.00	1076.00
2	9.00	45.00	135.00	270.00	540.00
3	6.80	34.00	102.00	204.00	408.00
4	4.93	24.67	74.00	148.00	296.00
5	4.13	20.67	62.00	124.00	248.00
6	3.40	17.00	51.00	102.00	204.00
7	3.00	15.00	45.00	90.00	180.00
8	2.60	13.00	39.00	78.00	156.00

5.3 Load Profile Status Flag

The statuses flagged in load profile are overflow, partial interval, long interval, skipped interval, test mode, power fail, clock set forward, clock set backward, and Daylight Savings Time in effect during interval. An overflow occurs when a count of 65535 pulses has been exceeded ($2^{16}-1$). A skipped interval is one that occurs during a time change or power outage that is longer than 2 intervals.

5.4 Load Profile Recording Channels AX and AXe

The available memory is distributed among channels depending on the programmable allocation table configured by the programming software. The metric for each load profile channel is selectable by the user with the programming software. Each channel has a configuration byte defining its selected metric. These configuration bytes may be read by the reader/programmer. The metrics available are as follows:

FOCUS AX and AXe Channels	
+kWh	-kWh
V2h/Vh Ph. A	V2h/Vh Ph. B
V2h/Vh Ph. C	I2/Ih Ph. A
I2/Ih Ph. B	I2/Ih Ph. C
Sag V Ph. A*	Sag V Ph. B*
Sag V Ph. C*	Swell V Ph. A*
Swell V Ph. B*	Swell V Ph. C*
Sag V Any Ph. *	Swell V Any Ph*
Delta Temperature	Temperature
Frequency	Delivered kVARh
Received kVARh	Delivered kVAh
Received kVAh	

*Voltage Sags and Swells for each phase use selectable thresholds.

FOCUS AXe Only Channels	
	Average Power Factor
Delivered kWh Rate A	Delivered kWh Rate B
Delivered kWh Rate C	Delivered kWh Rate D
Delivered kWh Rate E	Received kWh Rate A
Received kWh Rate B	Received kWh Rate C
Received kWh Rate D	Received kWh Rate E
Delivered kVARh Rate A	Delivered kVARh Rate B
Delivered kVARh Rate C	Delivered kVARh Rate D
Delivered kVARh Rate E	Received kVARh Rate A
Received kVARh Rate B	Received kVARh Rate C
Received kVARh Rate D	Received kVARh Rate E
Delivered kVAh Rate A	Delivered kVAh Rate B
Delivered kVAh Rate C	Delivered kVAh Rate D
Delivered kVAh Rate E	Received kVAh Rate A
Received kVAh Rate B	Received kVAh Rate C
Received kVAh Rate D	Received kVAh Rate E

Note on Volt hr and Amp hr pulses:

The pulse multiplier is the same value for both amp-hours and volt-hours and is stored in Mfg. table 24 as a "divider". For example the FOCUS AX divider value is 0.018554686. In order to use it as a multiplier, the reciprocal must be taken which is $1 / 0.018554686 = 53.89474$.

Multipliers listed by meter application are as follows:

Multiplier constant 53.89474 is used for:

- FOCUS AX AMR meters with firmware version 5.29 and later.

Multiplier constant 56.25000 is used for:

- FOCUS AX AMR meters with firmware version 5.28.
- FOCUS AX Gridstream integrated 0788 and 0881 meters (for all firmware versions).
- FOCUS AX Gridstream integrated 0881 meters (for all firmware versions).
- FOCUS AXe (for all firmware versions).

Volt-hours = Pulse count per interval x Intervals per hour x **Multiplier** (Volt-hours per pulse)

Amp-hours = Pulse count per interval x Intervals per hour x **Multiplier** (Amp-hours per pulse)

6 Energy Registers: Recordings and Displays

6.1 Digital Processing

The FOCUS AX meter family uses a power measurement chip that receives a voltage signal via a precision resistor divider network and a current signal through a current transformer. These AC signals are digitized into numeric values by a 21-bit analog to digital converter (ADC) operating at a 1,724.6 Hz rate. The 21-bit digitized voltage and current samples are processed by 32-bit digital signal processor (DSP) using digital multiplication techniques to produce high accuracy voltage, amperage, and watt-hour values. This information is provided to the microcontroller every 261ms for processing of energy accumulation, demand, time-of-use, and load profile billing information as well as for display on the liquid crystal display. A non-volatile data-flash memory device is employed for retention of programming and billing information when power is absent. All data is stored within ANSI C.12.19 tables.

6.2 Energy Accumulation

The FOCUS AX stores energy accumulation in 3 different registers. All three registers contain **unsigned** values. The Received (negative) register records energy that the utility receives from the end user. The Delivered (positive) register records energy that the utility provides or delivers to the end user. The Total (normal) register may be programmed to record in three different modes: Detent, Net, or Security. In **all** instances of handling negative energy measurement, the Digital Power Indicator (DPI) operates/moves on the LCD from left-to-right for Delivered energy and right-to-left when showing Received energy. Maximum demand values only accumulate for positive energy.

6.2.1 Programming for Detent (Ignore) Mode

Received energy is accumulated in the Received energy register and ignored in the Total energy register used for billing purposes. The Received energy is still recorded in the negative energy register, and can be displayed on the LCD. Selecting the Total kWh display shows only Delivered kWh, and the Negative kWh display shows only negative/reverse energy flow.

$$\text{Total kWh} = \text{Delivered kWh}$$

6.2.2 Programming for Net Mode

In Net mode, negative watt-hour measurements are accumulated in the negative register and subtracted from the Total energy register used for billing purposes. If, during a most unlikely condition, the reverse/negative flow of energy exceeds the recorded forward/positive flow of energy, the Total kWh (Net) display/register for a FOCUS AX goes to zero, and then continues counting down from 99,999. The Negative display/register continues to increment upward.

For example: if the Total kWh is 1100, and 75 Received kWh flowed through the meter, the new Total kWh is 1025.

$$\text{Total kWh} = \text{Delivered kWh} - |\text{Received kWh}|$$

[Go To Table Of Contents](#)

6.2.3 Programming for Security (Add) Mode

In Security (add) mode, Received energy flow is added to Delivered flow, and their total displayed/recorded in the Total kWh display/register. In other words, the negative kWh is accumulated (added) positively in the Total kWh register. Demand functions operate in their normal manner. All optional outputs also function normally.

$$\text{Total kWh} = \text{Delivered kWh} + |\text{Received kWh}|$$

6.3 Summary of Program Choices and Results

Total kWh (display/register): Calculated according to program mode selected

Detent (shows only Delivered kWh)

Net (shows Delivered - |Received| kWh)

Security (shows Delivered + |Received| kWh)

Delivered kWh (display/register)

Shows/records only positive kWh

Received kWh (display/register)

Shows/records only negative kWh

7 Transformer Factor (TF)

A transformer factor display is a 6-digit number available for display or for multiplication of readings when they appear on the display as selected by the user through the programming software. The FOCUS AX supports a transformer factor from 1 to 4,095. This value does NOT affect the recorded values in the meter's registers.

8 Demand Registers

Demand Registers are available for Delivered kW only. This includes the five highest kW demand peaks, as well as five cumulative and continuous cumulative demand values.

8.1 Demand Overflow

The meter detects and reports energy accumulation that exceeds the demand interval storage. Demand overflow can only occur if the meter is operated above its maximum rated current. Demand overflow is not the same as load profile interval overflow – See the load profile section for a description of load profile overflow.

8.2 Demand Intervals

The demand intervals may be whole minute divisors (or factors) of 60 minutes. Rolling demand may be selected with up to 15 subintervals per interval as shown in Table below. The time remaining in the current subinterval may be displayed. Maximum demand interval length is independent from the load profile interval length chosen.

DEMAND INTERVAL LENGTH (MINUTES)	NUMBER OF SUBINTERVALS								
	1	2	3	4	5	6	10	12	15
	SUBINTERVAL LENGTH (MINUTES)								
1	1	----	----	----	----	----	----	----	----
5	5	----	----	----	1	----	----	----	----
15	15	----	5	----	3	----	----	----	1
30	30	15	10	----	6	5	3	----	2
60	60	30	20	15	12	10	6	5	4

8.3 Maximum kW Demand

The maximum kW demand is calculated at the end of each demand subinterval. If the calculated demand is greater than the previous maximum demand, its value and the corresponding date and time are recorded. This feature is program-selectable to occur only if the previous maximum demand is exceeded.

8.4 Five Highest kW Demands

The five highest kW demands plus their corresponding date and time of occurrence are recorded and can be displayed. The five highest kW demands are independent of any TOU rate periods. Date and time of the five highest demands is recorded only if the meter is configured for TOU operation.

8.5 Demand Reset

A kW demand reset can be initiated by activating the lever arm reset switch on the front cover. An all-segment display is shown for a period of three (3) seconds to verify that the reset action has been accomplished. Demand reset may also be initiated via the optical port by a meter programmer or remote communications, as well as upon completion of a seasonal read or self-read. There are two demand reset types; the first sets all previous subintervals to zero, except for the present subinterval. The second type leaves all subintervals unchanged. The date of the last reset may be selected for display. The meter locks-out successive resets within a programmable length of time in order to prevent accidental multiple resets.

8.6 Power on Demand Delay Timing

Power on demand delay timing (PODT) allows for demand measurement to be delayed when power is restored after a power outage. The demand measurement may be delayed for times of 0 to 255 minutes. A time of zero minutes would cause no delay to occur. The value of PODT left is available for display. Additionally, in a TOU meter a PODT Trigger can be set to designate how long an outage has to be for the meter to utilize the PODT. This value can be programmed from 0 to 255 in minutes and from 0 to 59 in seconds.

9 Clock and Calendar Functions

Clock and calendar functions include a programmable software clock, a programmable dates calendar, adjustable time and date formatting, and an optional battery to maintain time through power outages. The internal clock accuracy is typically +/- 0.0020% (20ppm), or +/-1 minute drift per month.

9.1 Software Clock

The FOCUS AX and Service Disconnect have a software clock, which the microprocessor maintains by counting voltage line frequency cycles. The software clock maintains accurate time-keeping from line frequency or internal crystal-controlled clock (programmable). The current line frequency is available as a displayed quantity of at least one decimal place. The US and most of Canada have very precise 60 Hz line frequency; however the use of line frequency is not recommended if utility line frequency varies.

Without a battery, the clock remains operational for power losses up to 24 hours in meters manufactured since May 2009 and running firmware 5.33 or later.

9.2 Clock Setting

The FOCUS AX has the ability to change the date and/or time without reprogramming the meter. This is accomplished using software 1132Prog/Com, version 4.0 or higher, or via the AMI network. Setting time forward or backward past midnight results in the loss of all stored interval data, however, time set forward or backward within the same day would only result in long or short intervals with only skipped-over intervals being rewritten.

9.3 Date and Time Formats

The meter clock displays time in a 24 hour format of HH hour, MM minutes, and SS seconds. Midnight is considered to be the beginning of a day, and is displayed as 00.00.00.

The FOCUS AX can be programmed to display the date in a month/day/year format or in day/month/year or year/month/day (Canada) format. All dates are displayed in the same format. The date format configuration only affects the display of the date on the LCD, not the format in which the data is stored.

9.4 Calendar

The meter has the capacity for a calendar of 20 years taking into account 16 holidays/year, 4 seasons/year, and 2 daylight savings time adjustments/year with 5 daily TOU schedules/season and 8 switch points/day in TOU schedules.

9.5 Daylight Savings Time

Daylight savings time shifts follow US or user defined dates, and are programmed as normal dates through 1132Prog/Comm. On a spring time shift the time moves from 2 AM to 3 AM and a fall time shift moves from 2 AM to 1 AM.

9.6 Time on Battery Carryover

Time on battery carryover is recorded by the meter, and the cumulative carryover time is logged in the meter. Time on carryover is recorded in seconds but is displayed in minutes. If the display exceeds 999999 minutes, it rolls over to 000000. The time on carryover may be reset via 1132Comm or via a cold start. The battery has a nominal life of ten (10) years.

10 Power-fail Recovery

The FOCUS AX & Service Disconnect meter powers up after three seconds when minimum AC voltage is present, and then immediately begins following its programming and measuring designated functions (i.e. similar to the S4e).

11 TOU Power Outage Indication

Outage time is programmable and ranges from 1 to 16 seconds. Before load profile data is flagged with power outage markers or the outage is counted, a programmable number of seconds must have passed while the power was out.

For Power Outage Detection:

On firmware 5.33 and later:

The line voltage must drop below 73% of the nominal voltage for 100 ms (6 line cycles).

On firmware 5.32 and earlier:

The line voltage must drop below 73% of the nominal voltage for 33 ms (2 line cycles).

Once a power outage has been detected by the conditions stated above, the meter asserts the sys_reset signal (power fail indication to the communication device) and then performs its backup of billing data and then immediately begins checking for power restoration per the procedure below.

For Power Restoration:

If the meter's power supply indicates good DC voltage, the meter will then start its measurement module, and wait for 1 second for the measurement module to stabilize. A check that the phase voltage is above 73% of nominal voltage is done, and if it is, the meter initializes all subsystems, de-asserts the sys_reset signal, and begins metering.

12 Demand/TOU upgrade to TOU/LP

Time of Use (TOU) functions are available in the FOCUS AX demand version of the meter under either of the following conditions:

- **When a battery and TOU program are installed on the meter OR**
- **A two-way AMI system capable of keeping time and TOU program are installed. This is called TOU without battery.**

A FOCUS AX TOU meter can be upgraded to TOU/LP through 1132Comm programming.

[Go To Table Of Contents](#)

12.1 TOU Without Battery

The meter is configurable to ignore all errors and events resulting from a low or missing battery including clock error. The meter is configurable such that after a power outage, if it is not able to determine the current time, it defers some power up handling until it can, and enters stand-by mode (available only in firmware 5.31 and later).

12.2 "Stand-By" mode

When configured for Time of Use without battery and to allow stand-by mode, the meter enters stand-by after a power outage during which clock function was lost (see 9.1). Stand-by mode is designed to enable a utility to continue recording demand (firmware 5.31-5.33) and Load Profile (firmware 5.34) data while the meter is uncertain of the correct time.

Upon entering stand-by the meter's clock is set to 12:00AM 1/1/2000, a clock error is asserted, and an enter stand-by event is logged. Stand-by operation is indicated by a flashing "S/B" reading on the meter's display. In an operational AMI network, the meter should only remain in stand-by for a few seconds. However if a wide scale outage has occurred, the AMI network might take a period of time to fully function and to propagate the correct time to the meter. The meter does not allow any write commands during stand-by other than manufacturer unlock, cold-start, or set date and time. The firmware cannot be flashed while in stand-by mode. The meter does not exit stand-by unless the clock is set or a cold start is performed.

12.2.1 Stand-by in Firmware 5.31 to 5.33

The meter continues to register Delivered kWh, Received kWh, and Total kWh demand values. All TOU and LP recording is suspended. It is not possible to use the service disconnect while in stand-by mode. The meter ignores all demand reset commands. For subsequent outages in which time is lost again, the meter records an exit stand-by event at the time of the power loss, and then proceed to enter stand-by as normal.

12.2.2 Stand-by in Firmware 5.34 and later

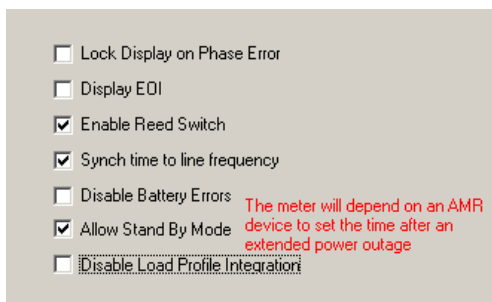

Selection in 1132Prog to allow Stand-by Mode and to enable or disable LP merging.

In firmware 5.34 (FOCUS AX) 5.62 (FOCUS AXe) and later, stand-by mode records Load Profile data. The meter stores up to 20 days of load profile information (1 channel) in 15 minute intervals for up to 3 months (see table 12.2.3 below). All power up and down events are recorded as in normal operation. The TOU rate and season are retained from before the power loss and do not change due to any calendar event. Self reads and season changes are skipped. The rate enunciator remains off.

On subsequent power outages in which the time is lost, the meter creates a new stand-by start event

in the log, but no stop event. The clock error is retained until either the time is set or a cold start is performed, and is not reset with a "Clear Standard Status flags" request. Test mode remains available, and data is not logged while in this mode (as normal). The meter can be programmed to merge the stand-by data with normal load profile data using the current time as a reference point upon exiting stand-by via a time set.

When a meter is powered in Stand-By mode it will record total kWh (energy values). Regular load profile quits recording and Stand-By load profile starts recording. When the meter time is reset, the meter will take the data accumulated during Stand-By and insert it into the regular load profile. There will be no time associated with the data recorded during Stand-By.

Use of a battery will retain all data and associated time. Data would be retained for as long as the battery held out. Once load profile is full you lose one interval of your oldest data each interval, power outage or not.

12.2.3 Load Profile Interval Length in Stand-by

Number of days in load profile Std Table 65 (with up to 6KB)

Channels	Interval Length (in minutes)				
	1	5	15	30	60
1	1.33	6.67	20.00	40.00	80.00
2	0.67	3.33	10.00	20.00	40.00
3	0.47	2.33	7.00	14.00	28.00
4	0.33	1.67	5.00	10.00	20.00
5	0.27	1.33	4.00	8.00	16.00
6	0.20	1.00	3.00	6.00	12.00
7	0.20	1.00	3.00	6.00	12.00
8	0.20	1.00	3.00	6.00	12.00

13 TOU

13.1 TOU Rate Schedules

The FOCUS AX & Service Disconnect has a total kilowatt hour accumulator and 15 programmable time-of-use (TOU) kilowatt hour accumulators, 5 each for Total, Received, and Delivered kWh. Each schedule has a variable number of switch points. A schedule is a collection of switch points defined for a particular season, holiday type, and day of the week. A switch point is a quarter-hour boundary during the day that defines a TOU rate change.

The meter supports up to four seasons, seven (7) day types for each season, and two (2) types of holidays for each season in the TOU rate schedule.

The FOCUS AX scans the TOU schedule to determine the proper rate in each of the following situations:

- Exiting test mode
- Exiting real-time mode

[Go To Table Of Contents](#)

- Upon executing a time change command
- Upon reaching quarter-hour boundaries
- Upon power-up, if the meter has **not** entered stand-by operation. If the meter did enter stand-by, then the scanning of the TOU schedule is done once the correct date and time is set.

13.2 TOU Switch points

A switch point is a quarter-hour boundary during the day that defines a TOU rate change and/or a programmable output option change. TOU schedules are made up of switch points. Each schedule may have from 1 to 96 switch points. The meter handles up to 240 switch points. Considering that the schedule definition requires the same space as a switch point, and that a schedule may have from 1 to 96 switch points, the table holds from 3 to 120 TOU schedules.

The number of allowed rates is up to five TOU periods: A, B, C, D and E. A rate period may last for as short as one switch point (changing every quarter-hour) or for as long as an entire day.

13.3 TOU Dates

The FOCUS AX calendar supports two types of dates - normal dates and every year perpetual dates. The normal dates are made up of a collection of one or more years of entries defining season changes, holidays, or daylight savings time shifts. The every-year perpetual dates handle holidays or season changes based on a non-moving day in the year. A total of 250 normal date entries and 16 perpetual date entries in the table are available on the FOCUS AX. Examples of perpetual dates are:

Jan. 1	New Year's Day
July 1	Canada Day
July 4	Independence Day
Nov. 11	Veteran's Day
Dec. 25	Christmas Day

Examples of normal dates are:

2 nd Sun. of Mar.	DST Begins
1 st Sun. of Nov.	DST Ends
4 th Thur. of Nov.	Thanksgiving (US)
Last Mon. of May	Memorial Day

13.4 Demand in TOU

When a TOU period comes to an end and a new rate goes into effect, the current demand interval is ended and demand calculation begins with a new demand interval. Demand data from before the TOU rate change is not used in the new TOU period. If the TOU change occurs in the middle of a demand interval, then the interval is split into two shorter intervals, each in their respective TOU rates.

If a maximum demand occurs at the end of the TOU period, and the demand interval is split, then the time of maximum demand recorded is not on a normal demand interval boundary. This is only an issue for 30 or 60 minute **block** intervals.

Example: 30 Minute Demand Interval with Rate A time change at 8:15am

When 8:15 am is reached, the current demand interval is ended early (half way into the interval.) If this short interval is a new maximum, the demand time stamp will be 8:15 am instead of ending on a 30 minute boundary (i.e. 8:00am or 8:30am.)

Each TOU rate records its own maximum kW (with date and time of occurrence). Each rate also has the coincident demand value at the time of the maximum demand. The coincident demand value operates off the same selection made for the five highest demand values.

14 Cold Starts

A cold start initializes all memory and returns the register to an un-programmed state. In this state, the register accumulates energy and demand data for 15 minute intervals and shows each metric in the default display during this condition. Test mode is not available. A cold start may be accomplished in two ways: optically or by a manual switch sequence that requires breaking the meter cover seal.

Caution: Cold starting a device results in an irreversible loss of billing data and the meter program.

14.1 Method 1, Optical Cold Start

1. In 1132 Com select RESET then Cold Start.
2. In 1132 Com a warning box to verify the cold start appears.
3. The message "Cold Start Complete" should appear to verify the cold start.

14.2 Method 2, Manual Cold Start

- 1) Hold the scroll switch for at least 6 seconds to enter fast scroll mode.
- 2) Release the scroll switch and press and hold the reset switch within 2 seconds. At this point the display is blank.
- 3) While still holding the reset switch down, within 2 seconds rapidly lift and then close the test mode switch.
- 4) Release the reset switch.

If the steps are not completed correctly and within the proper time sequence, the word "abort" shows on the LCD display. A demand reset occurs when the reset switch is pressed, but the cold start will not have occurred.

14.3 Register Displays following a Cold Start

After the meter is cold started, the display auto-scrolls through a power-up display sequence and then stops on the error code 000010. To review the power-up display sequence, please consult the section later in this manual entitled "Power-Up/Cold Start Displays".

15 Master Reset

A master reset clears all billing data in the register, while leaving the meter configuration program unchanged.

Events cleared in a master reset include:

-
- **Event and history log**
 - **Peak demand**
 - **Errors**
 - **TOU data**
 - **LP data**
 - **Energy accumulation**
 - **Voltage log data**

The master reset can be performed in two ways: 1) optically using 1132Prog/Comm software package and 2) manually using a manual switch sequence that requires breaking the meter cover seal.

Performing a master reset optically using 1132Prog/Comm

Follow the instructions for performing a master reset listed in the help file for 1132Prog/1132Com.

Performing a master reset manually using switches

- 1) Hold down the reset button on the face of the device.
- 2) Toggle the test switch up.
- 3) Release the reset button.
- 4) Hold down the reset button again.
- 5) While continuing to hold down the reset button, toggle the test switch down.

16 Programmable Output Switches

The FOCUS AX has an optional single output form C relay available. This relay toggles with kWh only. The relay board is the same KYZ board used on FOCUS AL and is only available if an AMI board is not installed.

17 Self-Reads

When activated, the self-read function saves a copy of all energy, demand, and TOU information, and records the current date and time in the self-read. Self-read data can be displayed. There are no self-reads available if the meter is configured for demand only operation.

17.1 Number of Self-Reads

Prior to FOCUS AX firmware version 5.37 and FOCUS AXe version 5.63 the meter was capable of displaying up to 6 sets of self-read data. Versions 5.37 and 5.63 introduced up to 12 sets of self-read data. A self-read initiates the transfer of current data into the next available self-read memory block, followed by an optional demand reset. Only the most recent number of self-reads are retained (the oldest self-read being replaced by the newest when the programmable number has been reached). If a season change and a self-read occur at 00:00:00 of the same day, the season change actions occur after the self-read.

17.2 Activation of Self-Read

Automatic self-read can be initiated in the following ways:

-
- **Day of month**
 - **Number of days since last reset**
 - **Every day**
 - **Demand Reset**

Day of Month

The range of the programmable day of month is 1 to 28 and the occurrence is at 00:00:00 of the specified day. Therefore, selecting the first day of the month actuates self-read at midnight just after the last day of the previous month. Calendar month billing is obtained by selecting the first day of the month as the day that the read should occur.

Number of days since last reset

Self-read occurs at the specified number of days programmed into the meter following the last demand reset. This assures that an automatic self-read would occur only if the normal monthly reading was missed.

Every Day

The Every day selection for self-read occurs each night at midnight.

Demand Reset

The fourth method, on a demand reset, can be completed via optical communication or physically pushing the reset switch. The first three actuation methods (day of month, hours since last reset, and every day) are mutually exclusive.

18 Security

When the FOCUS AX is programmed, a range of security features can be used. The security scheme consists of six levels of access to the meter, involving five communication security codes. Once the meter has been programmed, an operator must log in to the meter to establish a security level before any further programming commands are accepted. Read commands can be configured to require a log in or to allow access without one. The security level granted to the operator must be at least as high as the level programmed for the desired operation. If it is not, the meter rejects the command. The following table shows the requirements for each security level and the operations that can be done at that level.

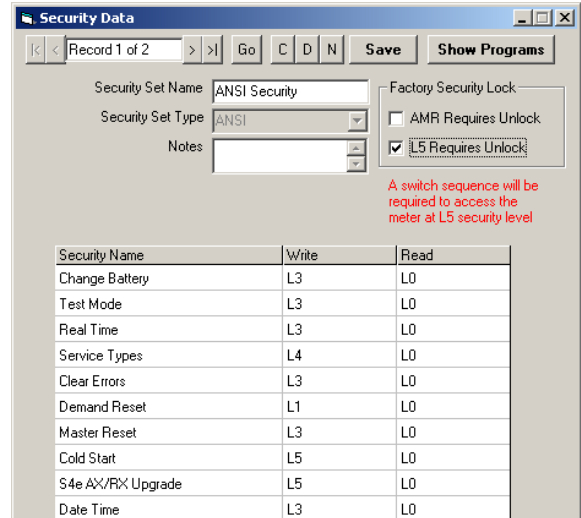

If meter has an AMR module, "AMR REQ UNLOCK" should not be selected in 1132Prog because a switch sequence is required in order for the meter to communicate with AMR module.

Security Levels and Operations Allowed

	Security key required	Operations allowed	Default key
L0	None	Read commands configured at L0 only	
L1	L1 password	L1 commands	11111111111111111111
L2	L2 password	L1 and L2 commands	22222222222222222222
L3	L2 password	L1, L2, and L3 commands	33333333333333333333
L4	L4 password	L1, L2, L3, and L4 commands	44444444444444444444
L5	L5 password	All commands	55555555555555555555

18.1 L5 Unlock Switch Sequence

- 1) Hold the scroll button until fast scroll begins
- 2) Flip up the test switch (while still holding the scroll button)
- 3) Release scroll
- 4) Flip down test switch

If this procedure is done correctly, the screen should blank for a moment, then proceed to the normal display sequence while flashing U/L. The meter re-locks if test mode is entered, if the programmed test mode timer times out or if the meter is power cycled.

[Go To Table Of Contents](#)

In 1132Com, the Toggle Security Lock allows a user to temporarily suspend the security lock using 1132Comm so that if there are operations which require multiple instances to perform the switch sequence, they can instead perform the unlock sequence once, toggle off the security lock feature, perform the operations they desire, and then toggle the security lock back on. If the user attempts to disconnect with the security lock toggled off and the L5 security lock was programmed to be enabled in the meter, 1132Comm warns the user that the security lock has not been turned back on.

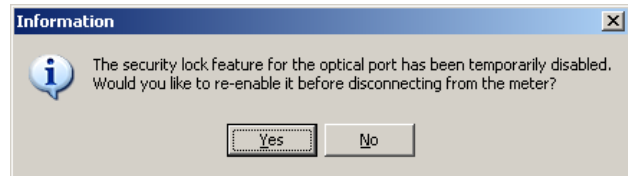

19 Voltage Quality Information

The FOCUS AX & Service Disconnect continually monitors instantaneous RMS voltage every 261ms (approximately 1/4 second) for evaluating voltage quality. The meter is capable of storing per phase volt-hours and amp-hours in Load Profile channels. Through 1132Prog/1132Com, the user can program in voltage sag and swell threshold values (such as 90% and 110%, for example). When the voltage exceeds the sag or swells thresholds, the information is recorded in load profile or communicated via a programmable output. Load profile sag and swell counts are updated every 261ms. Voltage sag and swell events are checked every 261 ms, and the event indicated when the sag started and stopped. In a FOCUS AX meter, the Digital Signal Processor (DSP) samples the voltage 1,724.6 times per second, integrating it over a 261 ms period. In a FOCUS AXe meter, the DSP samples the voltage 2520.6 times per second, integrating it over a 250 ms period.

19.1 Voltage/Max/Min./Avg

The min/max/average voltage is available in 5.33 and newer firmware. The table contains 70 entries (70 days) of daily min, max, and average voltage. The min and max voltages include a time stamp of when they occur during the day. The average voltage is stored at midnight for the previous 24 hour period. The meter allows voltage intervals of 5, 15, 30, and 60 minutes. (The voltage interval is separate from the demand interval and the load profile interval periods.) The meter's 1/4 second RMS voltage values are summed over the interval specified, and divided by the number of values summed. This results in an average RMS voltage over the interval for the min and max. The daily average voltage is an average of the voltage intervals over the day. These values are cleared with a master reset.

[Go To Table Of Contents](#)

19.2 Load Profile Voltage Sag Information

A threshold value can be set in the meter via 1132 Prog/Com for detecting voltage sags. If the voltage drops below this threshold, then a sag counter is incremented. This value accumulates every DSP sample period (see table below for sample periods by meter type). This counter continues to increment until the voltage is no longer less than the sag threshold. At the end of each load profile interval, this counter is stored, and then zeroed for the next interval. A load profile channel may be selected to record the value of the sag counter at the end of each load profile interval.

Meter Type	Firmware	Sample Period
FOCUS AX	≤ 5.28	~250ms
FOCUS AXe	≥ 5.29	~261ms
FOCUS AX Gridstream integrated	All Firmware versions	~250ms

19.2.1 Voltage Sag Alert

A threshold is provided for logging a voltage sag occurrence in the meter's event log. The voltage is inspected and an alert set when it drops below the sag alert threshold. This alert is cleared when the voltage is no longer below the sag alert threshold.

19.3 Load Profile Voltage Swell Information

A threshold value can be set in the meter via 1132 Prog/Com for detecting voltage sags. If the voltage drops below this threshold, then a sag counter is incremented. This value accumulates every DSP sample period (see table above for sample periods by meter type). This counter continues to increment until the voltage is no longer less than the sag threshold. At the end of each load profile interval, this counter is stored, and then zeroed for the next interval. A load profile channel may be selected to record the value of the sag counter at the end of each load profile interval.

19.3.1 Voltage Swell Alert

A threshold is provided for logging a voltage swell occurrence in the meter's event log. The voltage is inspected and an alert set when it exceeds the swell alert threshold. This alert is cleared when the voltage is no longer above the swell alert threshold.

19.4 Volt/Amp-hour

The summation of volt-hours (per phase) and amp-hours (per phase) is available for recording in a load profile channel. See section 13.4 Demand in TOU for pulse calculations.

20 Display Operation and GyrBox

Up to 48 displays are allowed to be selected in any order. Display items may also be used more than once during a display sequence. There are four display sequences:

- Normal
- Alternate
- Test Mode
- GyrBox Diagnostics

[Go To Table Of Contents](#)

The Normal Display sequence is present on the display if no special action is taken. The reed switch can be used to access both the alternate display sequence and the GyrBox display sequence. The activation and release of the reed switch (see section 1.3) in less than three (3) seconds activates the alternate sequence in the FOCUS AX & Service Disconnect.

Each display includes a three character identification number (ID). The identification number can be any number from 0 through 999 or can be a three character alphanumeric code. The identifiers are merely labels; numbers may be repeated and may be in any order.

Display values are not updated as they are shown, even if the value is changing internally in the meter. To display an updated value, it is necessary to scroll through all the display items until the value desired appears again. However, countdown timers, present demand, instantaneous measurements and Test Mode displays are updated during the display.

20.1 Diagnostic Display modes

Test mode may be entered with the Test Mode switch or via 1132Com. While in test mode, the displays must be manually scrolled using the Scroll switch. Demand, TOU, and LP data is not recorded while in Test mode.

Alternate displays are only shown in the Alternate ("ALT") Display sequence. Before the alternate display sequence starts, the word "ALT" appears on the display.

The GyrBox sequence is available via a reed switch actuation. Keeping the reed switch actuated for greater than three (3) seconds switches the FOCUS AX & Service Disconnect directly from the normal sequence to the GyrBox sequence, bypassing the alternate sequence (no "ALT" is shown). When entering GyrBox via the reed switch, 1/2 second before seeing the first GyrBox display (2 1/2 seconds after actuating the reed switch) the display goes blank to identify entry into the different display sequence. Releasing the reed switch from the GyrBox sequence returns the FOCUS AX to normal sequence.

The GyrBox sequence is also accessible via a scroll and test mode buttons combination. Pressing the scroll button for at least six (6) seconds to get into fast scroll mode and then flipping up the test mode lever while still holding the scroll button initiates the GyrBox sequence. After entering the GyrBox sequence, the scroll button may be released. Flipping down the test mode button causes the meter to exit the GyrBox sequence. The test mode button used in this fashion does not light up the TEST enunciator on the LCD since meter operation is not affected by the GyrBox display sequence.

Unlike Test mode, the GyrBox display sequence is not an operating mode. All normal meter functioning continues while in the GyrBox display sequence. The unique part regarding this sequence is that it is predefined. However, these displays do not subtract from the 1132 programmable displays. These displays may also be programmed to appear in the other display sequences, i.e., normal, alternate and test mode.

20.2 Scroll Modes

20.2.1 Auto Scroll Mode

The normal display default is auto scrolling. The auto scroll mode may be affected by a manual activation of another scroll mode or by the occurrence of an error. Auto scrolling is not active in test mode.

20.2.2 Scrolling in the Alternate Display Sequence

If the scroll switch is held down for more than 3 seconds, the Alternate Display sequence is shown starting with the first display item. If the scroll switch is held down for more than 6 seconds the fast scroll feature in the Alternate Display sequence is initiated. Also, the FOCUS AX meter auto scrolls unless the user scrolls the meter manually. If the end of the Alternate Display sequence is reached by either auto scrolling or manual scrolling, the FOCUS AX meter reverts back to the Normal Display sequence.

20.2.3 GyrBox

Once in the GyrBox sequence, via the reed switch or the button combination, the GyrBox displays auto scroll. After pushing the scroll switch for the first time (1sec), auto scrolling stops and the FOCUS AX is in the manual scroll. Unlike the alternate display sequence that just makes one pass before returning to the normal sequence, the GyrBox sequence wraps around to its first display. Either de-activating the reed switch or placing the test mode switch in the off position exits GyrBox, depending on the method of activation.

20.2.4 Manual Scroll Mode

While the FOCUS AX register is auto-scrolling, if the scroll switch is momentarily depressed, the display jumps to the next item in the sequence and auto-scrolling is suspended. Each subsequent press of the scroll button causes the display to show the next item in the sequence. The display resumes auto-scrolling when the switch has not been activated for one minute. Manual scrolling operates in this manner for both the normal, alternate, and GyrBox sequences. The test mode sequence never auto-scrolls.

Note: In Time of Use meters, the first time manually scrolling causes a battery test on TOU meters. If the battery voltage is low, an error code (see **section 22.1**) is indicated on the meter.

20.3 Digital Power Indicator

A six-segment Digital Power Indicator (DPI) is present on the display to allow a visual indication of one Kh value being recorded (equivalent to one disk rotation for an electromechanical meter). Each segment on the DPI represents one sixth ($1/6^{\text{th}}$) of the meter Kh value.

20.4 Rates

The LCD on the FOCUS AX & Service Disconnect indicates the currently active TOU rate (A, B, C, D or E). When real-time rate is active, the letter of the rate selected for real-time accumulation flashes at a 1 hertz rate, or approximately once every second.

20.5 Instantaneous Values

The "instantaneous" values of voltage and current are displayable on the meter LCD and are available through communications. The LCD shows nominal service voltage, but instantaneous readings must be programmed to be part of the display sequence. (see 19.11)

20.6 Power-Up/Cold Start Displays

Upon powering up, the meter auto scrolls through a power-up display sequence then stops on the error code and displays error(s) present.

The power-up display sequence shows five displays in Normal Mode:

- 1) DSP version
- 2) Firmware revision
- 3) Total kWh*
- 4) Maximum kW*
- 5) All-segment
- 6) Blank, or state of Service Disconnect switch

The following three displays are available in the Alternate Mode:

- 1) Full Load as left
- 2) Light Load as left
- 3) Power Factor as left

The following three displays are available in the Test Mode:

- 1) Total kWh
- 2) Max kW
- 3) Instant kW

*The default (cold-start) program measures kWh and kW on a 15 minute block interval.

If the meter is programmed, auto scrolling continues with the programmed displays after the catch-up period.

20.7 Display of Nominal Service Voltage

The meter has the ability to display nominal service voltage during power-up and as a selectable display. Nominal voltage is always displayed. Voltage values between 192 and 255 display as 240 volts nominal. The nominal service voltage is identified as the phase voltage that supplies power to the meter.

20.8 Potential Indicators

A potential indicator is shown on the LCD. If potential is lost on any phase, that phase indicator flashes.

21 Test Mode

Test Mode feature allows meter testing without affecting billing data, data collected is for test mode purposes only. Test mode is entered through the optic port or by activating the test mode switch on the face of the device. The register may be read while in test mode, but may not be programmed.

[Go To Table Of Contents](#)

21.1 Test Mode Display

Pressing the display scroll switch causes the next item to be displayed. Each test mode display value is updated continuously.

21.2 Actions upon Entering Test Mode

Upon entering test mode, the current demand interval is terminated and all billing data is stored. As a result, this demand interval is shorter than normal. The end-of-interval (EOI) output and display indicator both activate as if a normal EOI has occurred. If the present demand is greater than the previous maximum demand, maximum demand is updated.

21.3 Action upon Exiting Test Mode

Upon exiting test mode all billing data is restored and a new demand interval is started. The EOI output switch and display indicator activates, indicating the end of test mode and the start of a new demand interval and subinterval.

21.4 Test Mode Demand Functions

1132Prog/Comm allows programming of a separate demand interval length for test mode purposes. This allows for quicker verification of demand by using a shorter interval. A demand reset performed in test mode starts a new test mode interval and zeroes accumulated demand, maximum demand, and the number of register pulses recorded.

21.5 Miscellaneous Functions During Test Mode

Power on demand delay time (PODT) is not in effect during test mode, although timing continues. For example, if PODT is 10 minutes and the meter is put into test mode for four (4) minutes immediately on power up, the meter starts accumulating demand six (6) minutes after exiting Test Mode.

21.6 Test Mode Time-out

After a prescribed length of time, the test mode is automatically ended and the meter returns to normal mode. 1132Prog allows the user to program the test mode time-out value from 1 to 255 minutes (a value of 0 disables the time-out function) into the meter. Once test mode is entered, the test mode counter begins timing. If the meter is left in test mode longer than the time-out value, test mode ends. If any switch closure or optical communication occurs while in test mode, the time-out counter restarts counting at zero.

Note: If a meter leaves test mode due to inactivity time-out and the mechanical switch stays activated for longer than 4 minutes, the stuck switch error, if programmed, is displayed. This error is cleared after the switch is deactivated.

22 Self-Checking and Error Detection

22.1 Error Codes

The meter continuously monitors its operation for error conditions. Two types of error codes are flagged. Critical errors and operational errors are indicated in one error code while less critical conditions are indicated in another error code. The critical errors (flagged with the number *1) cause the error code to lock at the end of the display sequence. Activating the reed switch causes auto scrolling to continue for one more pass in the alternate display

[Go To Table Of Contents](#)

mode. The non-critical errors (flagged with the number *2) allow auto scrolling to continue with the error code inserted at the end of the display sequence. When more than one error is present, they are combined. For example, an error code of *1 010011 means that there is a non-scrolling error caused by a stuck switch, an un-programmed register, and a low battery. For example, a scrolling error code of 002000 suggests that an error has occurred due to a demand overload. The error conditions and their codes are defined below:

Error Condition	Display
Non-Scrolling Errors	
Low Battery Voltage	*1 000001
Un-programmed Register	*1 000010
Memory Error	*1 000100
Demand Overload	*1 001000
Stuck Switch	*1 010000
Scrolling Errors	
Low Battery Voltage	*2 000002
Phase Error	*2 000200
Demand Overload	*2 002000
Stuck Switch	*2 020000
Measurement Error	*2 200000

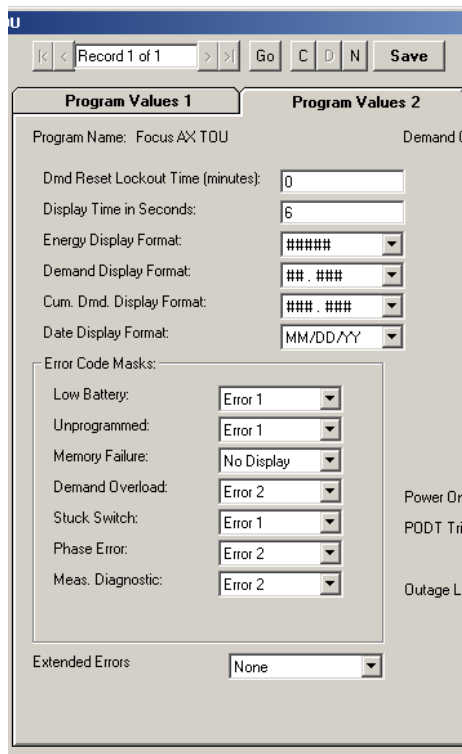

1132Prog allows programming of the Error Code Masks to select if errors are non-scrolling, scrolling, or not displayed (Error 1, Error 2, and No Display respectively).

22.2 Error Conditions

Low Battery	<p>The error is set when the battery voltage drops to 2.5 ± 0.2 volts. The battery voltage is automatically checked each day at 4 a.m. A check of the battery may also be initiated manually by actuation of scroll switch, actuation of Test mode, and each time a Demand Reset is performed. Note: A good charge on the Super Cap does not mask the state of a bad battery.</p> <p>Suggested action: Install a new battery and perform a battery retest as described above.</p>
Un-programmed	<p>This error is set upon completing a Cold Start.</p> <p>Suggested action: Program the meter using 1132Com</p>
Memory Error	<p>A failure in any of four memory components sets this error - a hardware failure in the serial EEPROM, or a checksum error in the ROM, SRAM or EEPROM. An auxiliary code is available for determining which part failed. Suggested action: Cold start and reprogram meter. If error returns, call technical support.</p>
Demand Overload	<p>See description in section Demand Overflow.</p> <p>Suggested action: With a transformer rated meter, use a higher ratio CT. With a self-contained meter, use a higher class meter.</p>
Stuck Switch	<p>Set when any switch (including reed switch) is activated for a programmable length of time.</p> <p>Suggested action: Flip test switch down, remove magnet from top, un-stick a push button, etc.</p>
Phase Error	<p>The AX registers the loss of phase voltage by blinking the potential indicator for that phase. No displays appear other than the error code displays, which may be seen by pressing the scroll switch. Phase error displays disappear when voltage is restored. Normal scrolling continues automatically.</p> <p>The "Invalid Service" error occurs if the meter has never detected a valid service type. The "Invalid Service" error clears when the meter is put in a valid service. The AX meter is powered from phase A, so any loss to this phase powers down the whole register and is treated as a normal power failure. Losses of phase B or C cause an error message to appear. A phase is considered lost at a programmable percentage of the nominal voltage, the default being 50%.</p> <p>Suggested action: Locate and fix error in wiring, ensure meter has not had any internal connections disconnected, etc.</p>
Measurement Error	<p>This error is an indication that a data overrun has occurred during processing in the ASIC. One or more time intervals of data may be lost.</p> <p>Suggested action: Select "Clear Errors" under the "Reset" pull-down menu of 1132Comm to clear this diagnostic.</p>

22.3 Disabling Individual Error Codes

Each error code has a programmable mask to allow the reader/programmer to enable or disable individual error conditions. Each error code is flagged by the meter, but is not displayed. The reader/programmer may clear any error condition by toggling the appropriate mask bit. If cleared, the meter retests for the error.

22.4 Demand Overload Operation

The Demand Overload error condition is cleared by a demand reset.

[Go To Table Of Contents](#)

22.5 Phase Voltage Errors

The FOCUS AX registers the loss of phase voltage by making an exception on the display. The FOCUS AX meter is powered from phase A, so any loss of voltage to this phase drops out the whole meter and is treated as a normal power failure. Losses of the other phases (on form 12S/25S) cause an error message to appear. A phase is considered lost at a user-programmable level of the nominal voltage. Based on the programmable option, the phase error display discontinues scrolling either temporarily or completely.

Phase error displays automatically disappear when voltage is restored to the phase. Normal scrolling continues automatically.

23 GyrBox Diagnostics

The function of the GyrBox diagnostics is to quickly and accurately conduct a meter and system electrical check. The per-phase information that the meter automatically calculates and displays indicates if the meter is installed and operating properly. The voltage and current measurements use RMS values with the voltage being updated every second and the current every five seconds continuously monitoring the installation.

23.1 GyrBox Support Software Packages

The GyrBox software is supported graphically and textually via the 1132 reading/programming software.

23.2 GyrBox Activation

GyrBox can be activated in either the normal or alternate mode of operation and continues normal energy measurement. The mode of activation is with the magnetic reed switch located at the 12 o'clock position. Upon activation, a display diagnostics enunciator flashes on the LCD. The reed switch is capable of being activated with the meter cover installed. The GyrBox continues to scroll through the diagnostics list when the magnet is removed or the scroll button is deactivated. GyrBox activation does not have any effect on billing quantities.

23.3 Digital Power Indicator (DPI) during GyrBox Activation

The DPI shows the direction of energy flow during each phase check. It moves left to right for forward/delivered flow, and right to left for reverse/received flow.

23.4 Display Format and Reference

The phase information is displayed with no leading zeros and one fixed decimal point. The diagnostic counters are displayed with leading zeros. The meter sets the "A" phase voltage phasor to 0.0° and calculates all other voltage phasors with relation to phase "A". Thus, phase "A" voltage is always be displayed as 0.0° . If the voltage is zero or too low to measure accurately (and thus the corresponding angle), then all three values on the LCD display dashes (---).



23.5 GyrBox Display List

The GyrBox scrolls through a defined set of diagnostic items/counters.

Description	Indicator	Display Format	Suffix
Phase "A" Voltage Angle	PhA	0.0°	V
Phase "A" Voltage	PhA	xxx.xxx	Vrms
Phase "A" Current Angle	PhA	*0.0°	I
Phase "A" Current	PhA	xxx.xxx	Irms
Phase "B" Voltage Angle	PhB	xxx.x°	V
Phase "B" Voltage	PhB	xxx.xxx	Vrms
Phase "B" Current Angle	PhB	*0.0°	I
Phase "B" Current	PhB	xxx.xxx	Irms
Phase "C" Voltage Angle	PhC	xxx.x°	V
Phase "C" Voltage	PhC	xxx.xxx	Vrms
Phase "C" Current Angle	PhC	*0.0°	I
Phase "C" Current	PhC	xxx.xxx	Irms
Number of Diagnostic 1 Errors	D1	xxxxx	
Number of Diagnostic 2 Errors	D2	xxxxx	
Number of Diagnostic 3 Errors	D3	xxxxx	
Number of Diagnostic 4 Errors	D4	xxxxx	
Number of Diagnostic 5 Errors	D5	xxxxx	
Number of Diagnostic 6 Errors	D6	xxxxx	
Number of Diagnostic 7 Errors	D7	xxxxx	

***Note:** The FOCUS AX family cannot report current angles due to a hardware limitation.

23.6 Diagnostic Checks

The following sections describe each of the diagnostics that GyrBox performs. When a diagnostic check is triggered it appears on the normal display sequence if it has been programmed to lock or scroll. After seeing the particular diagnostic error in the LCD display, compare the Phase A, B and C readings to the expected values found in **Appendix D: Normal Phase Angles**. Note which values are inconsistent and use that information to help track down the source of the error.

[Go To Table Of Contents](#)

23.6.1 Diagnostic D1 (Polarity, Phase, & Energy Flow Check)

This diagnostic checks for proper phasing of voltage and current circuits, incorrect polarity of voltage and current circuits, reverse energy flow of one or more phases, internal meter measurement malfunction, and faulty site wiring. The envelope of the voltage phasors and for current phasors is programmable. An error is detected if the values measured are outside of these boundaries.

Note: This error cannot occur on a FOCUS AX single phase meter (1S, 2S, 3S, 4S, 2K)

23.6.2 Diagnostic D2 (Phase Voltage Deviation Check)

The Phase Voltage Deviation Check verifies loss of phase voltage, incorrect phase voltage, shorted voltage transformer windings and incorrect voltage transformer ratio by detecting differences between phase voltage magnitudes. This check uses the "A" phase voltage as the reference voltage with the tolerance **equal to** the voltage range deviation (%) that is programmable with 1132 Prog software.

23.6.3 Diagnostic D3 (Inactive Phase Current Check)

This diagnostic check makes sure that the service is maintaining an acceptable current level and is expected to detect current diversion and an open or shorted CT circuit. The low current value is programmed into the meter via the 1132 Prog software and has a limit of 5mA to 200A in increments of 1mA. The error flag trips if one or more currents fall below the low current value and at least one current remains above this value for more than 15 seconds. The error flag must not trip if all phase currents fall below the low current programmed value.

Note: This error never occurs on a FOCUS AX single phase meter with a single CT (1S, 2S, 3S, 4S, 2K). In the cases of AX/AXe meter forms 2S (SD and non-SD), 2K and 4S, one CT is shared between the A and C phases in the meter. The meter hardware combines the two current values and firmware divides the value by 2 resulting in half of the current showing on phase A and half on phase C.

23.6.4 Diagnostic D4 (Phase Angle Displacement Check)

Beginning with FOCUS AX firmware versions 5.36 onward and FOCUS AXe 5.63 onward, the D4 diagnostic check is checking for each phase if the current angle leads more than the leading limit or lags more than the lagging limit. The D4 error will not be set for a phase which has a current below the D3 inactive current threshold. The limits are compared to the expected nominal current angle of the currently detected (or previously detected in the case of service error) service. This means, for example, that for a 45S in a 3-wire Delta service, where the nominal current angle for phase A lags the voltage by 30 degrees, and the nominal phase C current leads the voltage by 30 degrees, a leading threshold of 20 degrees would trigger a D4 condition if phase A current was 10 degrees lagging or less, or if phase C current was 50 degrees leading or more.

The D4 error could be set for a phase which has a current above the D3 inactive current threshold, even if simultaneously another phase is below the D3 inactive current threshold and has triggered a D3 error condition. The D4 error will never be set when the meter is in quadrants 2 or 3 relative to the expected current angle of the detected service on that phase. When a valid service has never been detected, this diagnostic is tested relative to the measured voltage angle rather than the expected current angle of a service.

[Go To Table Of Contents](#)

23.6.5 Diagnostic D5 (Future)

This diagnostic is reserved for future use.

23.6.6 Diagnostic D6 (Current Magnitude Imbalance Check)

This diagnostic compares the current of each phase with the other phases in the installation. If the ratio between any phase current and the average of all phase currents exceeds the user programmable percentage, then this diagnostic flag is tripped. The check is not performed if Diagnostic #3 did not pass, if the average current is below 0.5% of class, or if phase A voltage is missing.

Note: This error never occurs on a FOCUS AX single phase meter with a single CT (1S, 2S, 3S, 4S, 2K).

23.6.7 Diagnostic D7 (Energy Polarity Check)

The D7 diagnostic checks for reverse energy flow of one or more phases. If the energy polarity (watts) for any phase is negative, this flag is tripped. This check is not performed if phase A voltage is missing.

23.7 Diagnostic Counters

The GyrBox diagnostic counters count the number of times, incrementing by one, a diagnostic error occurred since the last counter reset. The range of the counters is between 0 and 65,535 and is reset to zero via 1132Com.

23.8 Diagnostic Error No-Check Conditions

The GyrBox diagnostics are not active during single-phase series conditions, while the meter is in test mode or when the GyrBox diagnostics have been disabled via 1132Com.

23.9 Diagnostic Check Output Contact

The error counters can be programmed via 1132Prog to communicate with an external device, through an output contact or the serial port that an error has occurred.

23.10 Tamper Detection

The Focus AX family of meters has the capability of detecting potential tampering attempts. If more than 255 pulses of reverse energy (1 pulse = Kh/12 watt-hours) are recorded in a 24 hour period, the meter will record a **Reverse Rotation Detected** event. This can be recorded in the meter's Optional Event Log and could be cause to investigate the reason for the reverse energy accumulation in a unidirectional electric service. Reverse Rotation Detected can be displayed on the meter's LCD and is indicated by S13. The **Reverse Rotation** flag is cleared by having 32 pulses of forward energy.

Focus AX will also record a **Tamper Attempt Detected** if a meter records 255 pulses of reverse energy following a power down / power up event. The **Tamper Attempt Detected** can also be recorded in the meter's Optional Event Log. The **Tamper Attempt Detected** could be an indication that a meter has been removed from a socket, turned upside down and

[Go To Table Of Contents](#)

reinserted into the socket in an attempt to lower the accumulated kWh. Tamper Attempt Detected can be displayed on the meter's LCD and is indicated by S12.

Additional anti-tamper features might include the meter recording an **Unauthorized Request** event or reporting that **Load Side Voltage** has been detected. An **Unauthorized Request** would be the result of an optical read or write attempt by someone not having proper security authorization (correct password) to perform those tasks. An **Unauthorized Request** can be logged in the meter's Optional Event Log. If the meter detects **Load Side Voltage** an alert will be provided when the meter is optically connected to via 1132Com. A **Load Side Voltage** detection alert following a remote attempt by a utility to reconnect a customer's service can be an indication that the customer has load side voltage present with the disconnect open.

23.11 Excessive Leading Current (Magnetic/DC Detection)

Beginning with FOCUS AX firmware 5.36 and AXe firmware 5.63 excessive leading current is used as an indication of possible metering tampering by using a magnet or the presence of DC. Focus AX and AXe has the ability to set an error flag for each phase if leading current angles above 10° are detected. The error flags are based on a fixed per-phase threshold angle of 10° for any meter form. These flags are non-user configurable. Per phase errors are set when the current angle for the detected service is leading and exceeds the per phase threshold of 10°. Per-phase start-stop events can be enabled to be logged in meter event log along with displaying optional extended error coded (phase A: M16, phase B: M17, phase C: M18) on LCD of meter. The alarms are cleared when the current angle falls 8°. Landis+Gyr recommends that this feature not be enabled for poly phase meters as there may be normal operating conditions that can cause an excessive leading current condition. It is recommended to use diagnostic D4 (see section 23.6.4) for applications requiring detection of excessive leading current conditions with a user configurable current angle.

The following errors can be cleared by using the Clear Errors function in 1132Com: Reverse Energy, Tamper, or Load Side Voltage error.

Some suggested recommendations to prevent meter tampering are listed below:

- Utilize optical port lockout and role-based access control
- Require 1132Com usernames and passwords for employees
- Make use of an event log audit trail to monitor meter programming events
- Change passwords to not be the default passwords
- Change the meter passwords every two years
- Utilize meter lockout to limit the rate that passwords can be attempted

24 Optical Port

24.1 ANSI Type II Optical Communications Port

Communication through the optical port is at 9600-38.4K baud. The optical port and calibration output share the same LED. Whenever the meter is not communicating, the LED will pulse at a programmable rate proportional to the watt-hours flowing through the meter. This calibration LED stops providing output pulses at midnight after being powered up. For a TOU meter, this means that the pulses are active for a minimum of 1 minute and a maximum of 24 hours depending on the meter's clock at power up. For a demand meter, the pulses always continue for 24 hours after power up. The calibration output pulse restarts after a power fail, power cycle, placing a magnet on the 12 o'clock position of the cover, or when entering test mode in AX meters with FW 5.38 and later and AXe with FW 5.64 and later.

24.2 Optical Port Lockout

Beginning with Focus AX firmware 5.36 and AXe firmware 5.63 the ability to completely lock-out the optical port of the meter by sending a command over an AMI network is present. A meter's optical port can be made active (not locked out) either indefinitely or for a programmable period of time when the unlock command is sent. The AMI network can be configured to send the lock-out command once per day in the event the meter's optical port is left unsecured unintentionally. An unsecured optical port will follow the L1 – L5 meter security as it exists in today's Focus AX. An intervening outage keeps the optical port unsecured for the remaining duration of the lock-out. If the outage duration exceeds the lock-out time OR if the outage duration causes stand-by mode, the meter secures the optical port upon power up. Any attempt to initiate an optical port lock-out procedure optically will be rejected by the meter.

25 FOCUS AX Service Disconnect

25.1 Applications

The FOCUS AX Service Disconnect Meter base can be used in a variety of applications without modification. The applications are as follows:

25.1.1 Manual Reconnect

In this application, it is possible to manually close the disconnect switch. This switch reset button is located on face of the meter on the upper-right side of the cover. The manual switch operation is possible without the need for special devices or tools. The manual reconnect provides a means of connecting service if a communications module is not present. Manually reconnecting the meter can only be performed if the meter has been "armed," via 1132Comm or AMI. **Troubleshoot:** Should the meter not return to the closed position when programmed to do so, but the switch toggles in the "armed" and "open" positions, check to make sure there is no load side voltage on the meter. The disconnect switch cannot reach the closed position when voltage is on the load side.

[Go To Table Of Contents](#)

25.1.2 Service Disconnect Closure Prevention

When "Prevent Switch Closure if Load Side Voltage is detected" is selected, the meter will reject commands to close the service disconnect switch when load side voltage exceeds the configured percentage of nominal voltage. For example, if the closure prevention is enabled and the configured threshold set to 5% of nominal voltage, the meter will reject a command to close if it detects in excess of 12V of load side voltage. A value of 0 will disable the check.

Legal Values: 0, 25 to 60% of Nominal Voltage when enabled

25.1.2 Service Disconnect Toggle Switch

Disabled: Switch is not activated, but meter remains programmable

Open: Switch is in the open position, preventing energy flow

Closed: Switch is in the closed position, allowing energy to flow

Armed: Switch is armed for local reconnection by end user

Enabled: Switch is activated, awaiting command

The following screen shots show how the Service Disconnect switch is operated in 1132Com. They show the switch in the open, closed, and armed states. The meter is reporting the line and the load side voltage for each state.

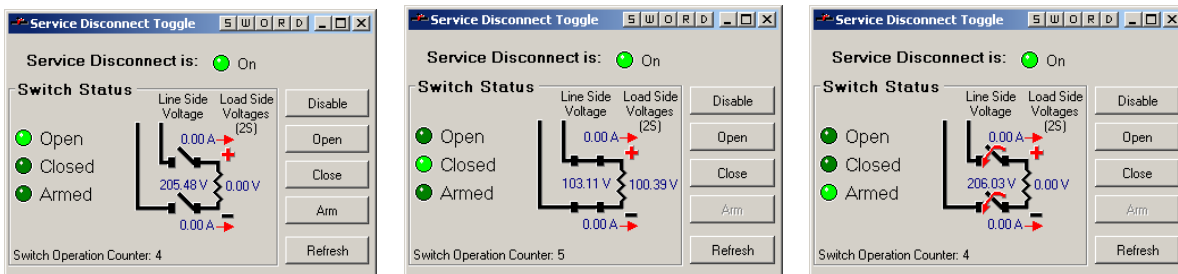

25.1.3 Switch Detection (SD Switch Operation Error)

The status of the switch is always the last commanded status (i.e. if program requires switch to be closed, the status on the LCD will display CLS). If there is an error in operation, the meter prompts an error. This operation error is set by the load side voltage. If the load side voltage is greater than (>) 10 V after an open, the meter prompts that there has been an error. Likewise, with a closed switch operation; if load side voltage is less than (<) 10V after a close, the meter prompts an error. This error is displayable, denoted by M00 if selected for display.

25.2 Remote Operation

This application is only used when a two-way communications module is installed in the FOCUS AX Service Disconnect meter. A remote signal is used to open and close the switch and check switch status. In addition, the ability to arm the switch for local/manual reconnection is also available. Configuring the meter to "arm" the switch is defined in the AMI software or 1132. Load side voltage is also detected prior to any remote reconnect or remote

[Go To Table Of Contents](#)

arming (for manual switch closure) of the meter. There is a programmable value that allows or disallows the presence of load side voltage to prevent any close operation.

25.3 Service Limiter (programmable time period)

Using this mode, the Focus AX-SD disconnects service when a certain watt hour usage is exceeded within a given interval of time. In 1132Prog, this is entered as a current at nominal voltage value and converted by the software to a watt-hour value. The switch then remains open for a set period of time, after which the meter can either close or arm the switch.

The disconnect switch opens immediately if this cumulative watt-hour threshold (also known as accumulation) is achieved within the specified time interval. The Wh threshold can be calculated by using the following formula: $Wh = (Amps)(Nominal Voltage) / (Intervals \text{ per hour})$. For example, 600Wh per interval is the same as 10 Amp at 240V with 15 minute intervals (4 per hour) because $10A * 240V / (4 \text{ intervals} / h) = 600Wh / \text{interval}$.

The meter will remain open for the specified number of minutes in "Open Time" before performing action, at which point the meter can be set to either close or arm the switch. When armed, the switch will close when the reconnect button on the front of the meter is pressed (if equipped). The open time can be set from 1 to 255 minutes, with zero (0) meaning to leave the switch open indefinitely. Upon closing the switch, the meter begins a new service limiter interval.

25.4 Soft Fuse (programmable kW level)

Soft fuse is identical to service limiter except that the monitoring period is 261ms (approximately 1/4 second), giving a near instantaneous response to high demand. All other features are the same.

25.5 Limiting Repeated Triggers

The FOCUS AX can limit the number of switch opening operations in a given time period. Upon the first switch open operation, the meter keeps track of the number of open operations for the programmed time period. If the programmable limit is exceeded, the switch **stays** open until the time period has passed from the time of the first switch open. Once the window expires, the meter follows the programmable auto-option (arm, close, or stay open).

25.6 Communications

The FOCUS AX Service Disconnect has the ability to remotely arm, open, and close the switch and to report switch status. Manual operation of the switch is possible regardless of the communication modules. The communication modules are mounted to the housing and connected via the 10-pin connector on the metrology board. Retrofitting the communication module does not require the meter base containing the disconnect switch to be opened. Opening the service disconnect switch base assembly voids the warranty, and may cause SD failure.

26 Error/Event Logs

Each individual extended error display can be set to No Display, Scroll, or Lock. When an error is displayed, its code will appear in the 3 character alphanumeric section of the display, and the 6 digit display shall indicate "Err0r".

26.1 Standard Error Configuration (LCD Displayable if selected, S##)

Display	Error Condition
	STD Errors
S00 error	Unprogrammed
S01 error	Unconfigured
S02 error	Self check (not currently used)
S03 error	RAM error (not currently used)
S04 error	ROM error (not currently used)
S05 error	Non-volatile memory error
S06 error Or "S/B" error	Clock error. Note: if stand-by mode is allowed, this display is "S/B" instead of "S06 Error".
S07 error	Measurement error
S08 error	Low battery voltage
S09 error	Low loss potential (not currently used)
S10 error	Demand overload
S11 error	Power failure
S12 error	Tamper detect
S13 error	Reverse rotation

Std Event 25: "Rate Change" means entering real time rate in the FOCUS AX implementation.

Std Event 27: "Tier Switch Change" means normal rate change in FOCUS AX implementation.

Std Event 42: Clock error happens when there is a running processor reset or the meter time is not set when meter is changed from AXD to AXT or AXR.

* These events are optional and recorded only if configured. All other events are always recorded.

26.2 Manufacturing Error Configuration (LCD Displayable if selected, M##)

Display	MFG Errors
M00 error	Service disconnect switch error
M01 error	Time adjustment (based on line frequency) error
M02 error	Voltage phase error (phase A, B, or C out, or invalid service)
M03 error	Not currently used
M04 error	Not currently used
M05 error	Stuck switch
M06 error	User programmable temperature threshold exceeded
M07 error	Not currently used
M08 error	Voltage phase A out
M09 error	Voltage phase B out
M10 error	Voltage phase C out

[Go To Table Of Contents](#)

M11 error	Invalid service (for service scan) e.g., Service= Delta, Wye, Voltage etc.
M12 error	Energy was accumulated while in standby mode
M16 error	Excessive leading current on phase A
M17 error	Excessive leading current on phase B
M18 error	Excessive leading current on phase C

26.3 FOCUS AX and AXe Special Indicators (Meter Displays)

Display	MFG Errors
R/C	Remote Communication: Appears on the meter display when an AMR device is communicating with the meter.
P/R	Programmer Reader: Appears on the meter display when optical communication is taking place.
Z/B	Zigbee: Appears on the meter display when a zigbee device is communicating with the meter.
OPN	Open: Appears on the meter display when the service disconnect switch is in the open state.
ARM	ARM: Appears on the meter display when the service disconnect switch is armed to be closed by either a network command or pushing the reconnect button on the cover.
CLS	Close: Appears on the meter display when the service disconnect switch is closed.
Z/F	Zero Fill: Appears on the meter display when the meter is in catch up and fills the TOU buckets with zeroes.
S/B	Stand By: Appears on the meter display when the meter is waiting for date and time to be set either optically or by communication network.
C/U	Catch Up: Appears on the meter display when the meter has exited standby mode and is back filling time of use registers.

26.4 Optional Event Definitions (Displayed in Meter Event Log if selected)

Event	Definition
Primary Power Down	Logged when power is lost. Event is time-stamped with the outage time.
Primary Power Up	Logged and time-stamped when power is restored.
Time Changed Old Time	Logged when the meter time is set. Records the meter time before the time change.
Time Changed New Time	Logged when the meter time is set. Records the time set.
Meter Accessed for Read	Logged when data is read from the meter.

[Go To Table Of Contents](#)

Meter Programmed	Logged when an unprogrammed meter receives a program thereby receiving a command to clear its unprogrammed error.
Communication Terminated Normally	Logged when a communicating device terminates a session.
Communication Terminated Abnormally	Logged when a communication session is ended by a timeout or error.
Reset List Pointers	Logged when Self Reads, Load Profile, History Log, or Event Log are initialized.
Update List Pointers	Logged when the number of Self Reads, Load Profile blocks, or Events read is updated. 1132Comm does not update these values; other reading devices may do so.
History Log Cleared	Logged when then History Log (std table 74) is reset.
History Log Pointers Updated	Logged when the number of History Log events read is updated.
Event Log Cleared	Logged when the Event Log (std table 76) is reset.
Event Log Pointers Updated	Logged when the number of Event Log events read is updated.
Demand Reset Occurred	Logged when a demand reset occurs.
Self Read Occurred	Logged when the meter performs a Self Read.
Daylight Savings Time On	Logged when daylight savings time begins.
Daylight Savings Time Off	Logged when daylight savings time ends.
Season Change	Logged when the meter's calendar enters a new season.
Rate Change	Logged when the meter enters Real Time Rate mode.
Special Schedule Activation	Logged when the meter enters a Holiday 1 or Holiday 2 rate schedule.
Tier Switch Change	Logged when the meter switches between TOU rates due to a scheduled rate change.
Test Mode Started	Logged when the meter enters Test Mode.
Test Mode Stopped	Logged when the meter exits Test Mode.
Meter Reprogrammed	Logged when a programmed meter receives a command to update its date and time programmed.
Configuration Error Detected	Logged if the meter has an Unconfigured Error at power up. The Unconfigured Error is set during meter manufacture and is cleared during the calibration process.
RAM Failure Detected	Logged when a failure to read from or write to RAM occurs.
Nonvolatile Memory Failure Detected	Logged when a failure to read from or write to nonvolatile memory occurs.
Clock Error Detected	Logged when power is lost and the meter's time has been lost and Stand-By mode is not enabled. Stand-By mode is designed for TOU Without a Battery operation on an AMI network and defers some power activity until time is set.
Measurement Error Detected	Logged when multiple energy samples from the basic metrology are lost during a 24 hour period.
Low Battery Error Detected	Logged when a battery test fails. The test is performed during programming, after power outages, after a demand reset, the first press of the scroll button, when commanded by 1132Comm and at 4 a.m. daily. Battery testing can be disabled in the program values. The error is set when the battery voltage drops below 2.5 +/- 0.2 volts.
Demand Overload	Logged when the configured demand overload threshold is exceeded.

[Go To Table Of Contents](#)

Detected	
Tamper Attempt Detected	Logged when the meter detects a power outage after which 255 Ke (Kh/12) of negative kWh are received with a 24 hour period.
Reverse Rotation Detected	Logged when the meter receives 255 Ke (Kh/12) of negative kWh within a 24 hour period.
Service Disconnect Operation	Logged when the meter accepts a command to open or close the service disconnect switch and when it successfully completes the operation.
Meter Log Failure	Logged when the meter rejects a logon or negotiate attempt or rejects a password.
Sag / Swell Start / End	Logged when a phase voltage sample exceeds the configured sag or swell threshold when the previous sample did not. A sag or swell end event is triggered when a phase voltage sample is within the configured sag or swell threshold when the previous sample was not. The event parameter will indicate which phases were affected.
Temperature Threshold	Logged when the instantaneous temperature sample exceeds the configured threshold when the previous sample did not.
SD Switch Operation Error	Logged when load side voltage levels indicate that a service disconnect switch operation may have failed.
Unauthorized Requests	Logged when a read or write attempt is rejected due to insufficient security access.
Meter Flash Event	Logged when the meter firmware is updated.
Sync Time to Line	Logged when the meter adjusts its time to maintain synchronization with the metered line frequency.
Standby Mode Entered	Logged when a meter enters Standby Mode following a power outage. Standby Mode is enabled as part of programming. It defers certain power up activities until the time is set to enable TOU without a battery solution on AMI networks.
Standby Mode Exit	Logged when a meter exits Standby Mode after a programming device sets the meter time.
Meter Removal/Insertion Detection	Logged when the tilt switch in a Focus AXe meter is triggered within 10 seconds of a power outage or restoration

27 Reactive Functions

In addition to all features and functions of the FOCUS AX, the following features are offered in RX Reactive.

27.1 FOCUS RX Available Forms

- Transformer rated: 3S, 4S
 - Self-contained: 1S, 2S, 12S, 25S
 - Extended Range (class 320): 2SE
 - K-base (class 480): 2K
 - Wide Range Power Supply, 120 – 277 VAC: 9S/8S, 12S, 12SE, 16S (14, 15, 17S), 16SE (14, 15, 17SE), 36S* (6S), 45S (5S)
- *Accuracy Class 0.5%

27.2 FOCUS RX Service Disconnect Available Forms:

- Self-contained: 1S, 2S, 12S and 25S

27.3 Software Upgrades to Reactive

Any FOCUS AX meter containing firmware 5.28 and newer can be upgraded to Reactive. Firmware Prior to 5.28 cannot be upgraded.

Using 1132Prog/Com V4.05 and higher along with 5.35 FW and higher along with a Hard Lock Key containing at least 10 bullets, an AX meter can be upgraded to Reactive Demand kM (kVA or kVAR) available in the 5 TOU rates. Coincidental reactive demand values include kM at time of Max kW and PF at time of Max kW. Load Profile Channel Selections include kVARh (Q1), kVARh (Q4), kVAh (Q1) and kVAh (Q4). Reactive Calculations

Available Reactive channels (meter must be upgraded to reactive functionality)

Q1 kVARh	Q4 kVARh
Q1 kVAh	Q4 kVAh

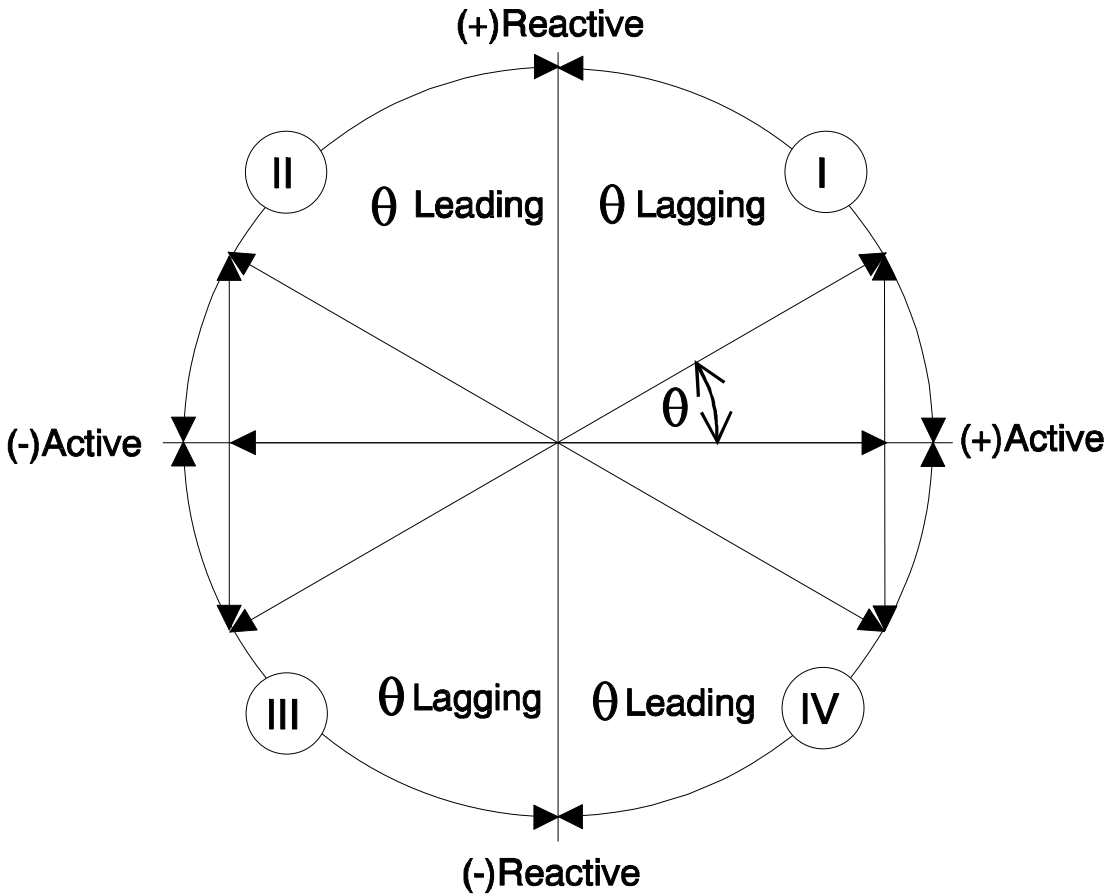

The FOCUS Reactive Enabled meter is capable of measuring and storing reactive energy that occurs in Quadrants 1 and 4. You can chose *one* of the two reactive metrics, kVARh *OR* kVAh, for registration in the regular register read. The selected reactive metric can also be designated as the Demand Variable. In other words, The standard kW demand will be replaced by **kM** demand in the regular register read. You can record and examine both reactive metrics as Q1 and Q4 kVARh or Q1 and Q4 kVAh in the Load Profile data (if the meter is so equipped), regardless of which one is selected for the regular register read.

Quick reference for reactive metric choice and whether to Detent, Net, or Add, reactive accumulation:

2 Quadrant Method

Choice made between kVARh or kVAh (kMh) at time of meter programming:

Delivered kVARh Lag (Q1)

Received kVARh Lead (Q4)

kVARh for billing choice: Detent - Q1 Add - Q1+Q4 NET - Q1-Q4

OR

Delivered kVAh Lag (Q1)

Received kVAh Lead (Q4)

kVAh for billing choice: Detent - Q1 Add - Q1+Q4 NET - Q1-Q4

kVAh calculated by vectoral method: $kvah = \sqrt{(kwh^2 + kvarh^2)}$

[Go To Table Of Contents](#)

27.4 Additional Reactive Support

There is a second method of calculating reactive energy consisting of 4 Quadrant Metering:

For Focus AX firmware versions greater than or equal to 5.37 and less than 5.60, and for Focus AXe firmware versions greater than or equal to 5.63 this additional 4 quadrant selection controls in which quadrants the selected reactive metric will be recorded.

4 Quadrant Method

Delivered kVAh	Q1+Q4
Received kVAh	Q2+Q3
Delivered kVARh	Q1+Q2
Received kVARh	Q3+Q4

Total VAh or VARh (not both at same time) can be calculated by one of three options below for either of the two reactive modes:

- Total VAh = VAh delivered **or** (VAh delivered +VAh received) **or** (VAh delivered – VAh received)
- Total Varh= Varh received **or** (Varh delivered + Varh received) **or** (Varh delivered –Varh received)

The following load profile channels will be supported regardless of reactive mode:

Del kVAh
Rec kVAh

Del kVARh
Rec kVARh

No independent quadrant reactive data will be available.

27.5 Programming for Detent (ignore), Add, or NET with Reactive Metrics

If kVARh is chosen as the “kMh”:

+kVARh Lag (Q1)
+kVARh Lead (Q4)

Detent = Q1 only (Q4 is ignored)
Add = Q1 + Q4
NET = Q1 – Q4

If kVAh is chosen as the “kMh”:

[Go To Table Of Contents](#)

+kVAh Lag (Q1)
+kVAh Lead (Q4)

Detent = Q1 only (Q4 is ignored)
Add = Q1 + Q4
NET = Q1 – Q4

27.6 Three Highest kW Demands-Reactive

Reactive option is limited to the three highest KW demands plus their corresponding date and time of occurrence are recorded and can be displayed. The five highest kW demands are independent of any TOU rate periods. Date and time of the five highest demands is recorded only if the meter is configured for TOU operation..

27.7 Active and Reactive energy calculations

The Active and Reactive energy calculations on the Focus AX include up to the 14th harmonic and supports directly measured VARs using the integral method that attenuates harmonics.

28 AXe Features

The E331 and E351 Focus AXe and AXe-SD family of meters offer enhanced features and functions. Additional features such as meter security and tamper-proofing have been included.

The Focus AXe hardware has been improved to include a microprocessor that runs 2X faster than the Focus AX processor (9.8MHz vs. 4.9 MHz). The available ROM on the Focus AXe has doubled from 64KB (in the Focus AX) to 128KB. Non-volatile data storage has increased from 2 Megabits on Focus AX to 8 Megabits on the Focus AXe.

28.1 FOCUS AXe Available Forms

- Transformer rated: 3S, 4S
- Self-contained: 1S, 1S-SD, 2S, 2S-SD, 12S, 12S-SD, 25S, 25S-SD
- Extended Range (class 320): 2SE
- K-base (class 480): 2K

28.2 FOCUS AXe Service Disconnect Available Forms:

- Self-contained: 1S, 2S, 12S and 25S

Below are descriptions of the enhanced features for the Focus AXe.

28.3 Load Profile Recording Channels AXe

See section 5.4 for a list of AX and AXe load profile recording channels.

28.5 Secondary Demand Recording

A Reactive enabled Focus AXe meter (RXe) with firmware 5.64 and later supports a second demand recorder. This value is programmed to record the same demand metric as the coincident demand.

1132Prog Selections vs Demands Recorded for Reactive Enabled Focus AXe 5.64:

1132 Prog Selections				
Reactive Metric	Received kM	Demand Metric	Demand Recorded	Secondary Demand Recorded
kVARh	Ignore	Active Demand (kW)	kW	kVAR Delivered
kVARh	Ignore	Reactive Demand (kM)	kVAR Delivered	kW
kVARh	Add	Active Demand (kW)	kW	kVAR Added
kVARh	Add	Reactive Demand (kM)	kVAR Added	kW
kVARh	Net	Active Demand (kW)	kW	kVAR Delivered
kVARh	Net	Reactive Demand (kM)	kVAR Delivered	kW
kVAh	Ignore	Active Demand (kW)	kW	kVA Delivered
kVAh	Ignore	Reactive Demand (kM)	kVA Delivered	kW
kVAh	Add	Active Demand (kW)	kW	kVA Added
kVAh	Add	Reactive Demand (kM)	kVA Added	kW
kVAh	Net	Active Demand (kW)	kW	kVA Delivered
kVAh	Net	Reactive Demand (kM)	kVA Delivered	kW

28.6 Tilt Tamper Detection

Focus AXe has an on-board tilt sensor for detection of vibration and / or "tilt" as a means to alert a utility that a meter has possibly been removed from its socket.

- If vibration/tilt was detected in the 10 seconds before power down, reset, etc. this can indicate meter removal.
- If vibration/tilt was detected in the 10 seconds after power up, reset, etc. this can indicate meter insertion.

If either of the above conditions is met an event can be logged in the meter's event log.

[Go To Table Of Contents](#)

Hardware/Firmware feature (only AXe) based on omnidirectional tilt and vibration sensor. Acts like a normally closed switch which chatters open and closed as it is tilted or vibrated. The sensor is environmentally friendly. No hazardous materials (mercury). Non-user configurable limits are preset based on extensive L+G testing.

28.7 AXe LCD Displays

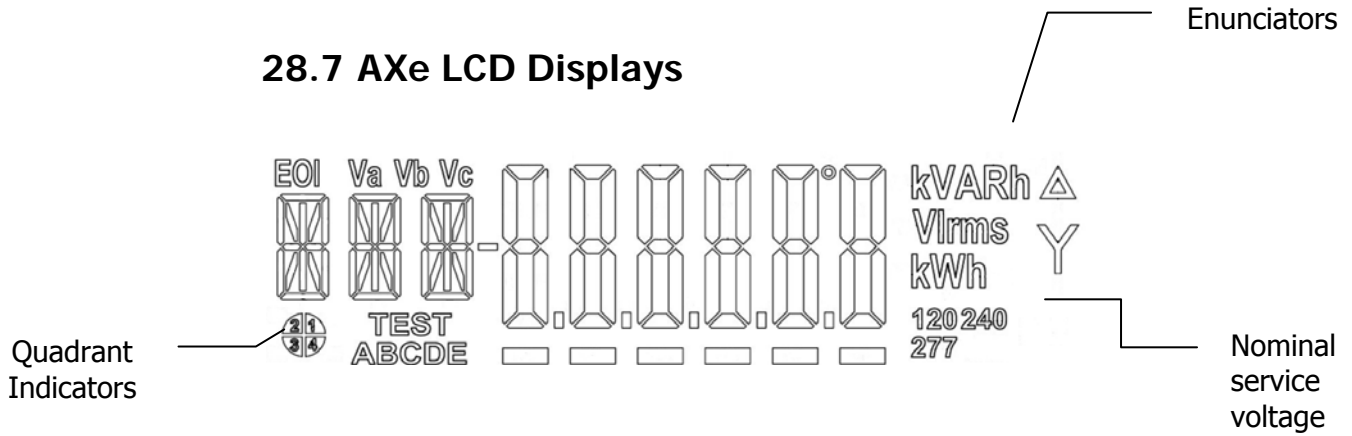

AXe LCD Display

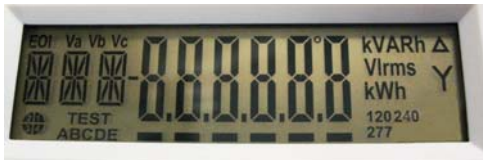

Variations in LCD hue is normal

Appendix A: Resources and Standards

Reference Documents:

Federal Communications Commission

Pending, dependent on AMI

American National Standards Institute

American National Standard Code for Electricity Metering, ANSI C12.1

American National Standard for Watt-hour Meters, ANSI C12.10

American National Standard for Protocol Specification for Type 2 Optical Port ANSI C12.18

American National Standard Code for Electricity Metering, ANSI C12.19

American National Standard Code for Solid State Electricity Meters, ANSI C12.20

American National Standard Code for Electricity Metering, ANSI C12.21

American National Standard Code for Electricity Metering, ANSI C12.22

American National Standard Method of Salt Spray (Fog) Testing, ANSI/ASTM B117, (Z118.1 1974)

Canadian Specifications

National Standards of Canada "Specifications for Approval of Type of Electricity Meters, Instrument Transformers and Auxiliary Devices", CAN3-C17-M84

National Standards of Canada "All-Numeric Dates and Times" CAN 3-Z234.4-79

Ontario Hydro, "Oscillatory Transient Interference Immunity Test", A-28M-82

Ontario Hydro, "Susceptibility of Electronic Equipment to Radiated Interference", C-5047-77

Class B digital apparatus complies with Canadian ICES-003

IEC 687 - (Electrical Specifications)

FCC Class B Emissions

Appendix B: K-Base Meter Top/Bottom Feed

On the bottom of all form 2K meter base plates, there are two moveable links. All 2K meters leave the factory configured for top-feed application. In order to set the meter for bottom-feed application, these links need to be repositioned.

The following photos show the position of the links for top and bottom-feed applications. The design differs slightly for old electromechanical (MS-2K) and Altimus 2K meters as compared to FOCUS AL and AX meters.

Step 1: Loosen ALL screws enough to slide each link from the top-feed position to the bottom-feed position.

Step 2: Securely tighten ALL screws.



FOCUS AL and AX Top-Feed



FOCUS AL and AX Bottom-Feed

Appendix C: Technical Specifications

Nominal Conditions:

Name	Symbol	Value
Line Voltage	Vn	120, 240 Volts
Line Frequency	Fn	60 Hz (± 5%)
Power Factor (cosine theta)	PF	1 (± 0.15% of Full Load)
Ambient Temperature	Ta	23
Temperature (inside cover)		-40°C to 85°C
Humidity (non-condensing)	Rh	Relative Humidity <= 95% Rh
Wide Range Line Voltage	Fu?	120-277 Volts

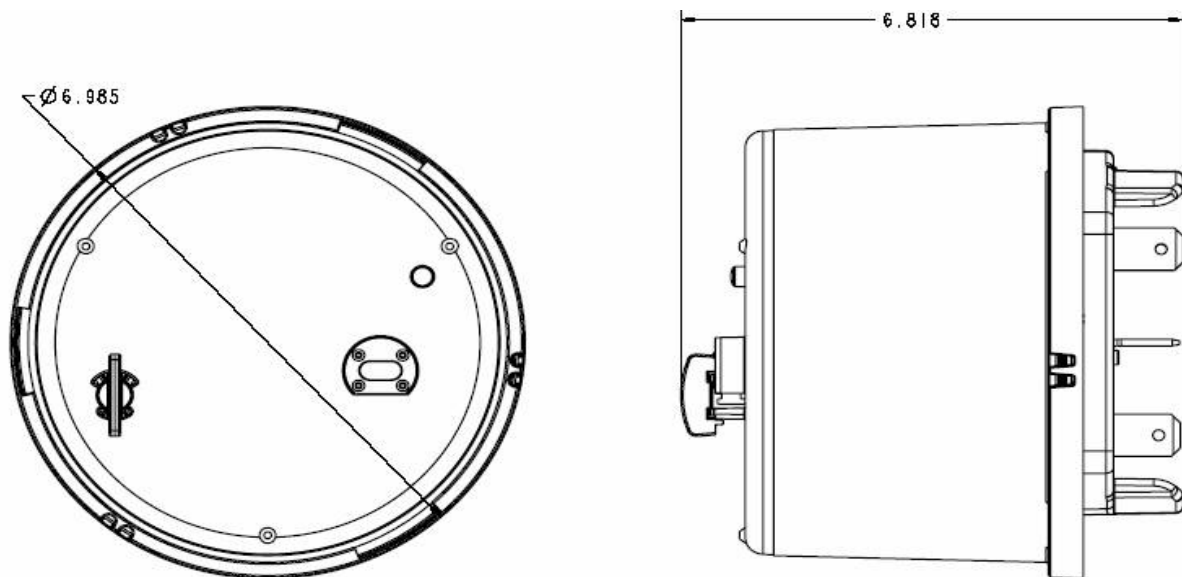

Internal Meter Loss:

Rated Voltage Input Specifications:

The Voltage Operating Range (minimum/maximum rated voltage) for the FOCUS AX is 80% to 120% Vn.

Rated Starting Load

Meter Type	% of I max	Load Current (Amps)
Class 20	0.020	0.005
Class 100	0.025	0.025
Class 200	0.025	0.050
Class 320	0.015	0.050
Class 480	0.025	0.120

[Go To Table Of Contents](#)

Load Performance

Load Performance of the FOCUS AX & Service Disconnect meter complies with limits set in ANSI C.12.20 for Class 0.2 Accuracy.

Voltage Reading Accuracy

Voltage accuracy readings in the meter are +/-1%

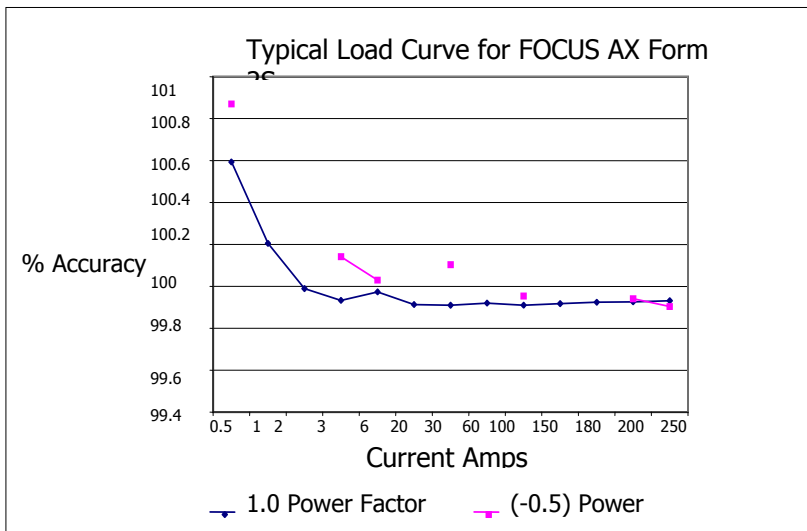

Current & Voltage Burden

The current burden on the FOCUS AX 2S meter is <.25W max at 30A. The voltage burden is approximately <1.9W these results are determined from ANSI requirements.

Over-Current & Over-Voltage Withstand

The over-current withstand is 7000A. The over-voltage withstand is 150% for 0.5 seconds and 130% for five (5) hours. These results are determined from ANSI requirements.

Current Ratings and Withstand

Class	TA (Amps)	Maximum Rated Current	Temporary Withstand*
20	2.5	20 Amps Peak	7000 Amps Peak
100	15	100 Amps Peak	7000 Amps Peak
200	30	200 Amps Peak	7000 Amps Peak
320	50	320 Amps Peak	7000 Amps Peak
480	50	480 Amps Peak	7000 Amps Peak

*Note: Temporary Withstand is rated at ¼ cycles.

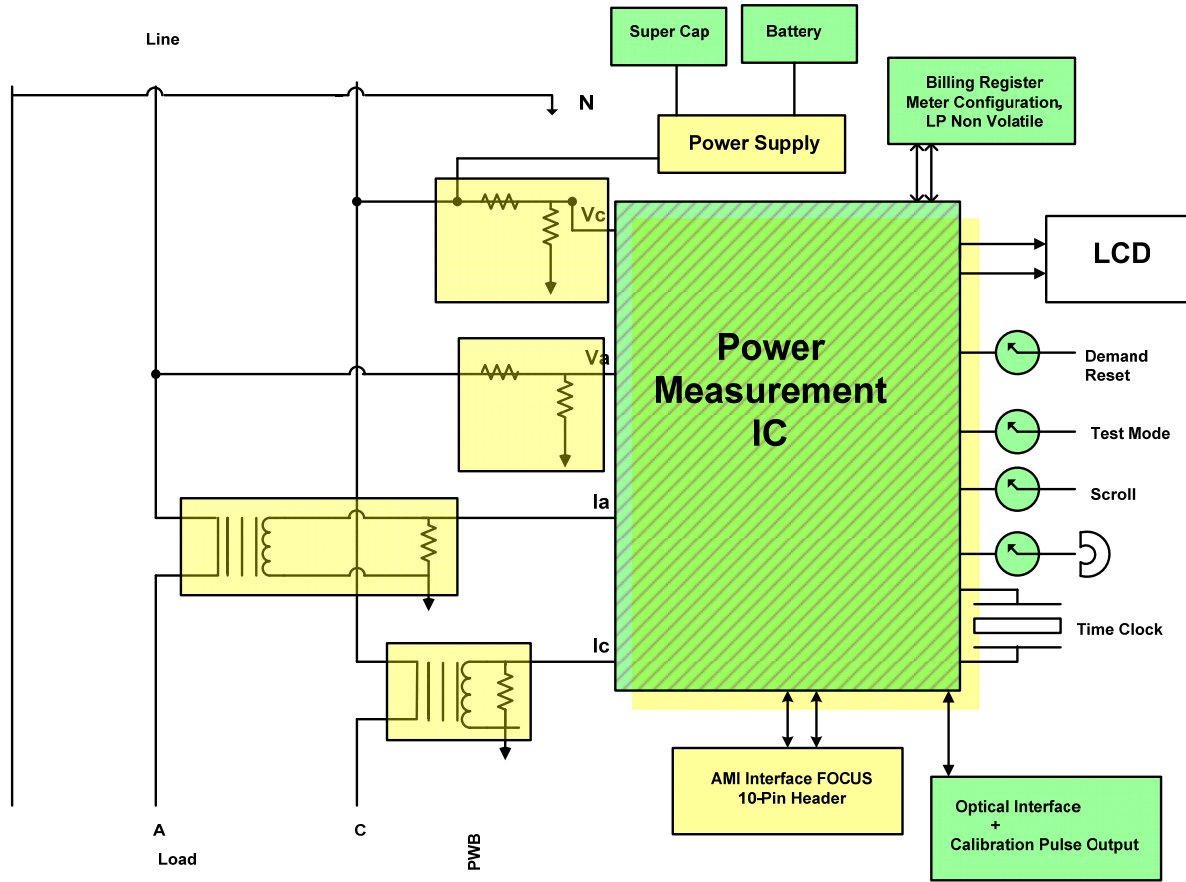

Legend

Battery – 3.6V Lithium battery for backup during outages maintains timekeeping and registers.

Clock – Maintains the timing for energy and demand calculations

Demand Reset – Switch activates the demand reset sequence.

LCD – Display on front of the meter, can be programmed to scroll through up to 48 displays.

Load Profile Memory –Memory used for storing load profile register data.

Optical Interface + Calibration Pulse Output – This an ANSI type II optic port that operates as a calibration LED during testing.

Power Measurement IC – The power measurement IC analyzes the incoming voltage and current inputs to perform basic measurement calculations.

Power Supply – Converts incoming AC on phase A to low voltage DC for meter operation.

Reed Switch – Switch activated magnetically and used to access Alternate mode and GyrBox mode.

Scroll – Scroll is used to deactivate auto-scroll and to step through the individual displays.

Test Mode – The test mode switch activates test mode.

Time Clock – Time keeping device maintaining TOU time during power outages.

Appendix D: Normal Phase Angles

The following charts outline the ideal voltage phase and current phase angles. Phase and current voltages will depend upon the application.

Note: The FOCUS AXR does not report current angles due to a hardware limitation.

1S Single-phase, 1 element, 2-wire	Phase A	Phase B (Center)	Phase C (Right)
Voltage	0°	N/A	N/A
Current	0°	N/A	N/A

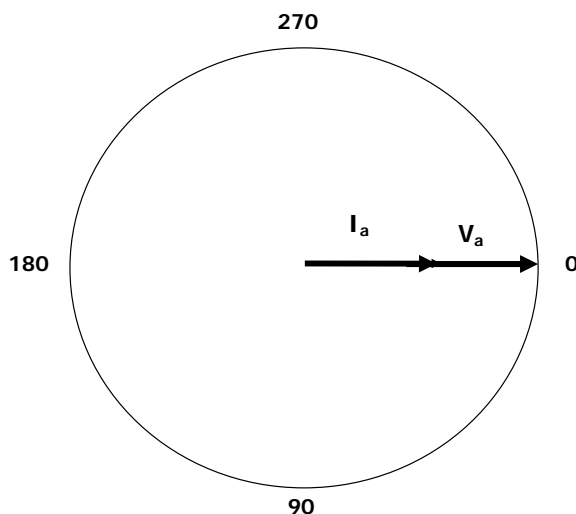

2S/2SE Single-phase, 1 1/2 element, 3-wire	Phase A	Phase B (Center)	Phase C (Right)
Voltage	0°	N/A	180°
Current	0°	N/A	180°

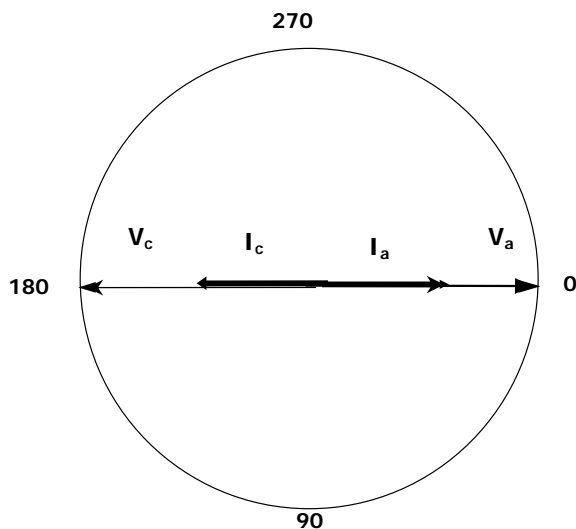

[Go To Table Of Contents](#)

2K Single-Phase, 1 1/2 element, 3-wire	Phase A	Phase B (Center)	Phase C (Right)
Voltage	0°	N/A	180°
Current	0°	N/A	180°

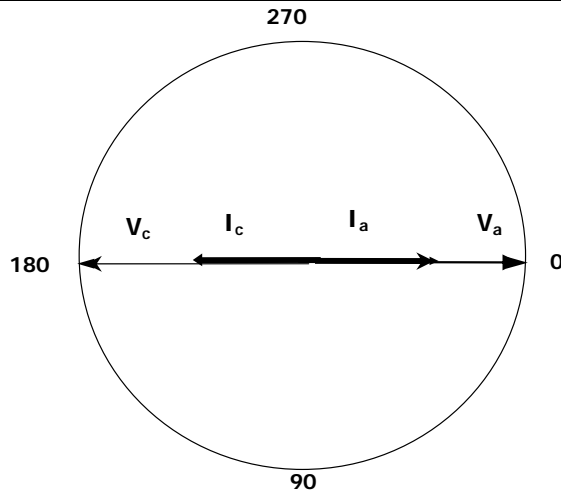

3S Single-phase, 1 element, 2-wire	Phase A	Phase B (Center)	Phase C (Right)
Voltage	0°	N/A	N/A
Current	0°	N/A	N/A

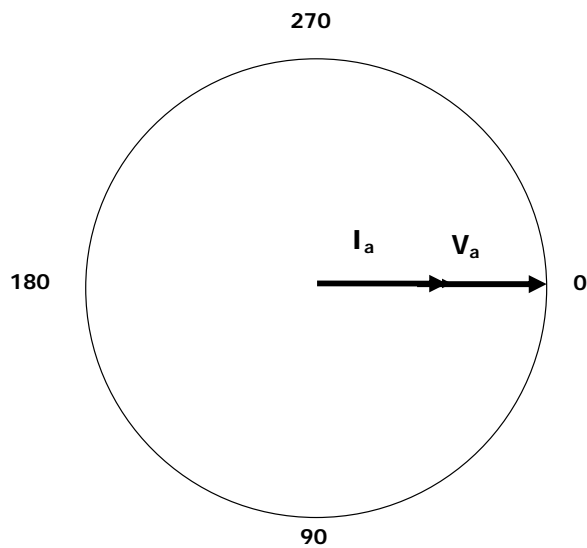

3S Single-phase, 1 1/2 element, 2-wire	Phase A	Phase B (Center)	Phase C (Right)
Voltage	0°	N/A	180°
Current	0°	N/A	180°

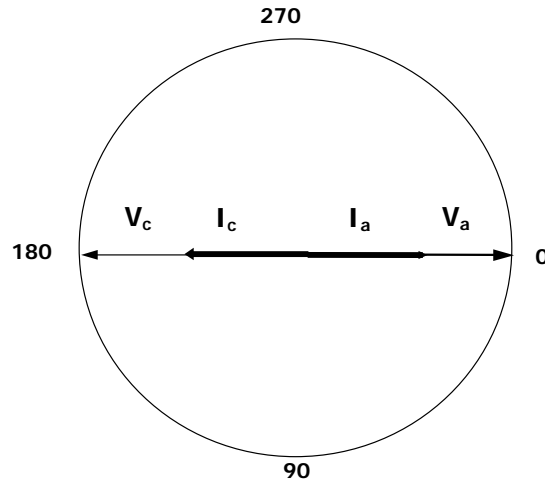

12S 2 element, 3-wire Wye; A, B, C phase rotation	Phase A	Phase B (Center)	Phase C (Right)
Voltage	0°	N/A	240°
Current	0°	N/A	240°

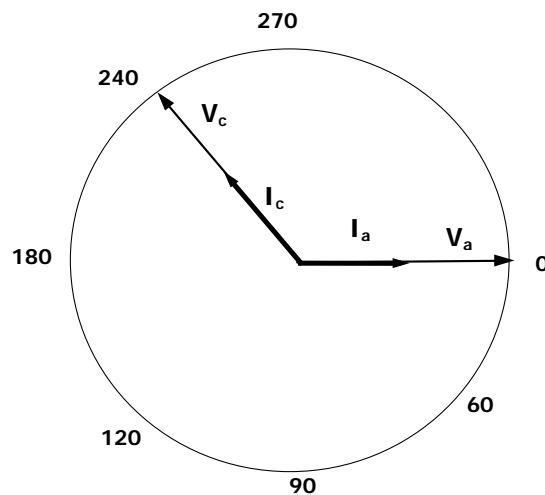

[Go To Table Of Contents](#)

25S 2 element, 3-wire Wye; A, B, C phase rotation	Phase A	Phase B (Center)	Phase C (Right)
Voltage	0°	N/A	240°
Current	0°	N/A	240°

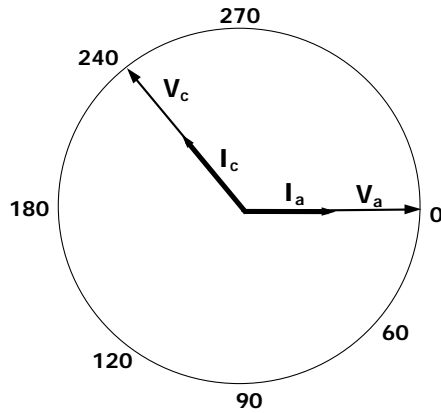

45S (5S) 3-Wire Delta Service	Phase A (Left)	Phase B (Center)	Phase C (Right)
Voltage	0°	N/A	300°
Current	30°	N/A	270°

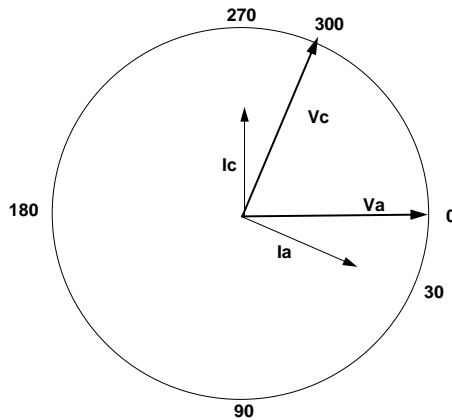

36S (6S)--Unity power factor with load connected line to neutral	Phase A (Left)	Phase B (Center)	Phase C (Right)
Voltage	0°	120°	240°
Current	0°	120°	240°

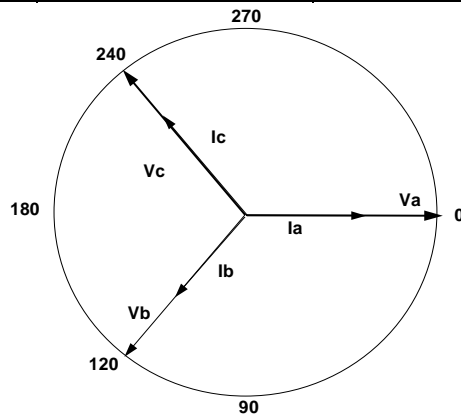

[Go To Table Of Contents](#)

9S/8S--Unity power factor with load connected line to neutral	Phase A (Left)	Phase B (Center)	Phase C (Right)
Voltage	0°	120°	240°
Current	0°	120°	240°

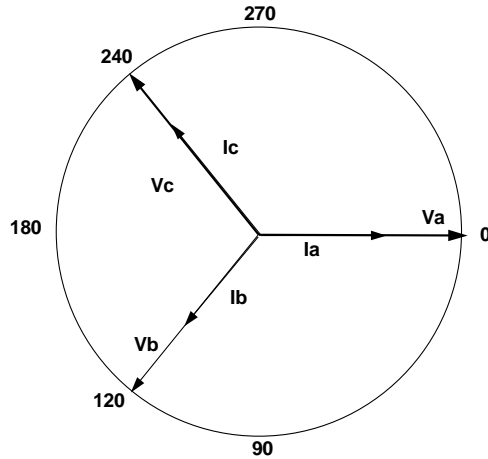

16S/16SE, 3 element, 4 wire wye; A, B, C, phase rotation	Phase A (Left)	Phase B (Center)	Phase C (Right)
Voltage	0°	120°	240°
Current	0°	120°	240°

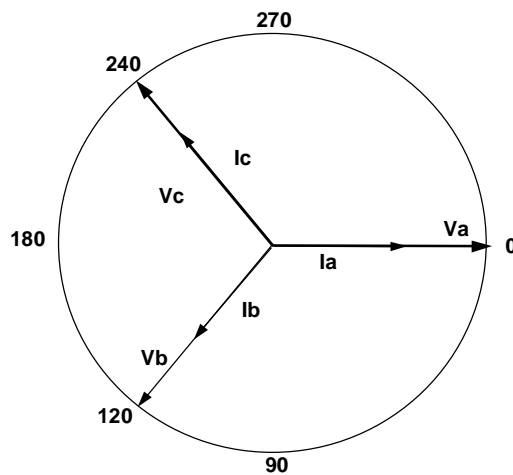

[Go To Table Of Contents](#)

Appendix E: Service Types

Meter Form	Index	Service Type										Expected Current Angle (A)	Expected Current Angle (B)	Expected Current Angle (C)
			CONFIG	ROTATION	WIRES	SERVICE_VOLTAGE	VOLTS_PH_A	VOLTS_PH_B	VOLTS_PH_C	PHASE_ANGLE_A_TO_B	PHASE_ANGLE_A_TO_C			
1S	0	1PH 120V	1PH	-	2	120	120	0	0	Skip	0	0	0	0
2S, 2K	0	1PH 240V	1PH	-	3	240	120	0	120	0	0	0	0	0
3S	0	1PH 120V	1PH	-	2	120	120	0	0	Skip	0	0	0	0
3S	1	1PH 240V	1PH	-	3	240	120	0	120	0	0	0	0	0
4S	0	1PH 240V	1PH	-	3	240	120	0	120	Skip	0	0	0	0
16S	0	4WY- 120v	Y	ABC	4	120	120	120	120	120	240	0	120	240
16S	1	4WY- 277v	Y	ABC	4	277	277	277	277	120	240	0	120	240
16S	2	4WY- 120v	Y	CBA	4	120	120	120	120	240	120	0	240	120
16S	3	4WY- 277v	Y	CBA	4	277	277	277	277	240	120	0	240	120
16S	4	4WD- 240v	D	ABC	4	240	120	120	208	180	270	30	150	270
16S	5	4WD- 480v	D	ABC	4	480	240	240	416	180	270	30	150	270
16S	6	4WD- 240v	D	CBA	4	240	120	120	208	180	90	330	210	90
16S	7	4WD- 480v	D	CBA	4	480	240	240	416	180	90	330	210	90
16S	8	3WD- 120v	D	ABC	3	120	120	0	120	skip	300	30	-	270
16S	9	3WD- 240v	D	ABC	3	240	240	0	240	skip	300	30	-	270

[Go To Table Of Contents](#)

Meter Form	Index	Service Type										Expected Current Angle (A)	Expected Current Angle (B)	Expected Current Angle (C)
			CONFIG	ROTATION	WIRES	SERVICE_VOLTAGE	VOLTS_PH_A	VOLTS_PH_B	VOLTS_PH_C	PHASE_ANGLE_A_TO_B	PHASE_ANGLE_A_TO_C			
16S	10	3WD-120v	D	CBA	3	120	120	0	120	skip	60	330	-	90
16S	11	3WD-240v	D	CBA	3	240	240	0	240	skip	60	330	-	90
16S	12	3WY-120v	Y	ABC	3	120	120	0	120	skip	240	0	-	240
16S	13	3WY-277v	Y	ABC	3	277	277	0	277	skip	240	0	-	240
16S	14	3WY-120v	Y	CBA	3	120	120	0	120	skip	120	0	-	120
16S	15	3WY-277v	Y	CBA	3	277	277	0	277	skip	120	0	-	120
16S	16	Total entries for 16S forms												
12S/25S	0	3WD-120v	D	ABC	3	120	120	0	120	skip	300	30	-	270
12S/25S	1	3WD-240v	D	ABC	3	240	240	0	240	skip	300	30	-	270
12S/25S	2	3WD-120v	D	CBA	3	120	120	0	120	skip	60	330	-	90
12S/25S	3	3WD-240v	D	CBA	3	240	240	0	240	skip	60	330	-	90
12S/25S	4	3WY-120v	Y	ABC	3	120	120	0	120	skip	240	0	-	240
12S/25S	5	3WY-277v	Y	ABC	3	277	277	0	277	skip	240	0	-	240
12S/25S	6	3WY-120v	Y	CBA	3	120	120	0	120	skip	120	0	-	120
12S/25S	7	3WY-277v	Y	CBA	3	277	277	0	277	skip	120	0	-	120
12S/25S	8	Network	S	ABC	3	120	120	0	120	skip	180	0	-	180
12S/25S	9	Network	S	ABC	3	240	240	0	240	skip	180	0	-	180
12S/25S	10	Total entries for 12S/25S forms												
9S	0	4WY-120v	Y	ABC	4	120	120	120	120	120	240	0	120	240
9S	1	4WY-277v	Y	ABC	4	277	277	277	277	120	240	0	120	240
9S	2	4WY-	Y	CBA	4	120	120	120	120	240	120	0	240	120

[Go To Table Of Contents](#)

Meter Form	Index	Service Type										Expected Current Angle (A)	Expected Current Angle (B)	Expected Current Angle (C)	
			CONFIG	ROTATION	WIRES	SERVICE_VOLTAGE	VOLTS_PH_A	VOLTS_PH_B	VOLTS_PH_C	PHASE_ANGLE_A_TO_B	PHASE_ANGLE_A_TO_C				
		120v													
9S	3	4WY-277v	Y	CBA	4	277	277	277	277	240	120	0	240	120	
9S	4	4WD-240v	D	ABC	4	240	120	120	208	180	270	30	150	270	
9S	5	4WD-480v	D	ABC	4	480	240	240	416	180	270	30	150	270	
9S	6	4WD-240v	D	CBA	4	240	120	120	208	180	90	330	210	90	
9S	7	4WD-480v	D	CBA	4	480	240	240	416	180	90	330	210	90	
9S	8	Total entries for 9S forms													
36S	0	4WY-120v	Y	ABC	4	120	120	120	120	120	240	0	120	240	
36S	1	4WY-277v	Y	ABC	4	277	277	277	277	120	240	0	120	240	
36S	2	4WY-120v	Y	CBA	4	120	120	120	120	240	120	0	240	120	
36S	3	4WY-277v	Y	CBA	4	277	277	277	277	240	120	0	240	120	
36S	4	Total entries for 36S forms													
45S	0	3WD-120v	D	ABC	3	120	120	0	120	skip	300	30	-	270	
45S	1	3WD-240v	D	ABC	3	240	240	0	240	skip	300	30	-	270	
45S	2	3WD-120v	D	CBA	3	120	120	0	120	skip	60	330	-	90	
45S	3	3WD-240v	D	CBA	3	240	240	0	240	skip	60	330	-	90	
45S	4	3WY-120v	Y	ABC	3	120	120	0	120	skip	240	0	-	240	
45S	5	3WY-277v	Y	ABC	3	277	277	0	277	skip	240	0	-	240	
45S	6	3WY-120v	Y	CBA	3	120	120	0	120	skip	120	0	-	120	
45S	7	3WY-277v	Y	CBA	3	277	277	0	277	skip	120	0	-	120	

[Go To Table Of Contents](#)

Meter Form	Index	Service Type										Expected Current Angle (A)	Expected Current Angle (B)	Expected Current Angle (C)
			CONFIG	ROTATION	WIRES	SERVICE_VOLTAGE	VOLTS_PH_A	VOLTS_PH_B	VOLTS_PH_C	PHASE_ANGLE_A_TO_B	PHASE_ANGLE_A_TO_C			
45S	8	4WD-240v	D	ABC	4	240	120	120	208	180	270	0	-	270
45S	9	4WD-480v	D	ABC	4	480	240	240	416	180	270	0	-	270
45S	10	4WD-240v	D	CBA	4	240	120	120	208	180	90	0	-	90
45S	11	4WD-480v	D	CBA	4	480	240	240	416	180	90	0	-	90
45S	12	Single phase	S	ABC	3	120	120	0	120	skip	180	0	-	180
45S	13	Single phase	S	ABC	3	240	240	0	240	skip	180	0	-	180
45S	14	Total entries for 45S forms												

Appendix F: Meter Form Schematic Diagrams

Self-contained meter forms

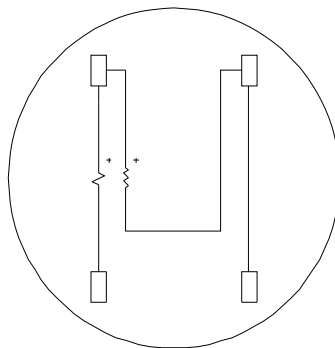

Form 1S Specification

Form	Class	Test Amps	Volts	Wire	Kh
1S	100	15	120	2	1.8

[Go To Table Of Contents](#)

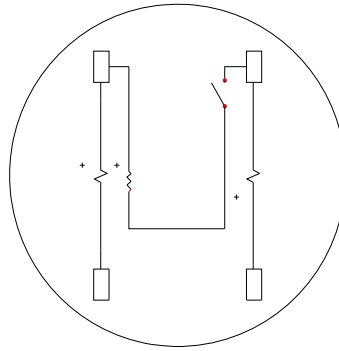

Form 2S/2SE Specifications

Form	Class	Test Amps	Volts	Wire	Kh
2S	200	30	240	3	7.2
2S	200	50	240	3	7.2
2SE	320	50	240	3	12
2SE	320	30	240	3	12

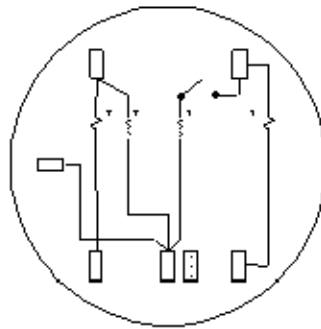

Form 12S (Network)

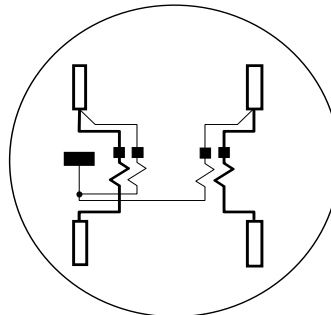

Form 25S

Form 12S and 25S Specifications

Form	Class	Test Amps	Volts	Wire	Kh
12S	200	30	120/208	3	14.4
25S	200	30	120/208	3	14.4

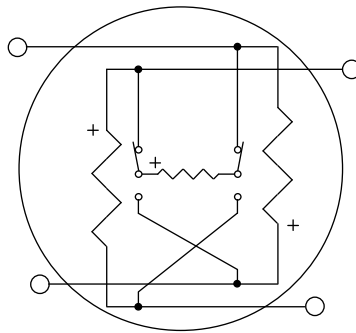

Form 2K Specifications

Form	Class	Test Amps	Volts	Wire	Kh
2K	480	30	240	3	14.4
2K	480	50	240	3	14.4

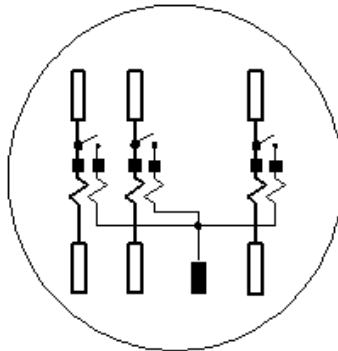

Form 14S, 14SE, 15S, 15SE, 16S, 16SE, 17S, 17SE Specifications

Form	Class	Test Amps	Volts	Wire	Kh
14S	200	30	120/277	4	21.6
14SE	320	50	120/277	4	21.6
15S	200	30	120/277	4	21.6
15SE	320	50	120/277	4	21.6
16S	200	30	120/277	4	21.6
16SE	320	50	120/277	4	21.6
17S	200	30	120/277	4	21.6
17SE	320	50	120/277	4	21.6

Transformer Rated Meter Forms

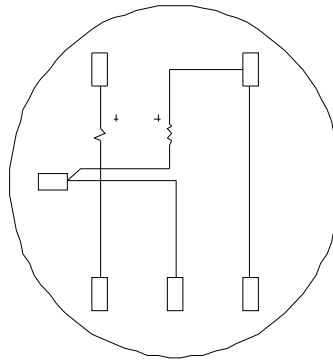

Form 3S Specifications

Form	Class	Test Amps	Volts	Wire	Kh
3S	10	2.5	120	2	.3
3S	20	2.5	120	2	.3
3S	10	2.5	240	2	.6
3S	20	2.5	240	2	.6

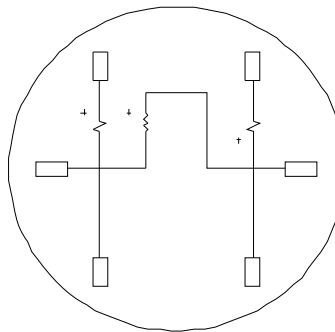

Form 4S Specifications

Form	Class	Test Amps	Volts	Wire	Kh
4S	10	2.5	240	3	.6
4S	20	2.5	240	3	.6

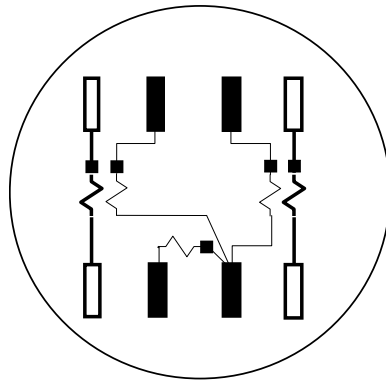

Form 45S (5S) Specifications

Form	Class	Test Amps	Volts	Wire	Kh
45S (5S)	20	2.5	120-277	3	1.2

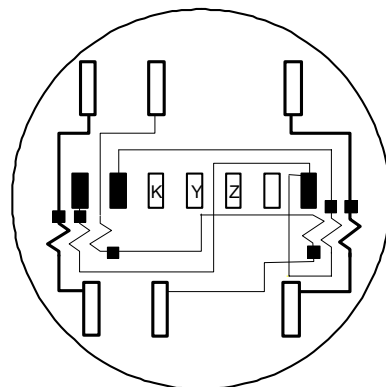

Form 36S (6S) Specifications

Form	Class	Test Amps	Volts	Wire	Kh
36S (6S)	20	2.5	120-277	4	1.8

****36S has a rated accuracy class of 0.5%**

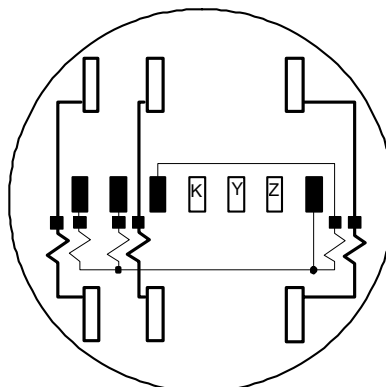

Form 8S Specifications

Form	Class	Test Amps	Volts	Wire	Kh
9S (8S)	20	2.5	120-277	4	1.8

[Go To Table Of Contents](#)